

Reyco Granning

S U S P E N S I O N S

Model 21B & 21½B (Cast & Fab)

On/Off Highway

Suspension System

Installation and

Maintenance Instructions



Installation Instructions Model 21B

COMPANY PROFILE

Tuthill Transport Technologies is the new Line of Business name arising from the acquisition and merger of two companies in the heavy-duty suspension and off-road axle industries. These companies were formerly known as Fluidrive, Inc. of Brookston, IN and Reyco® Industries, Inc. of Springfield and Mt. Vernon, MO and Reyco® Canada of Grimsby, Ontario. Tuthill Corporation purchased Fluidrive in December, 1998 and purchased Reyco® in February, 1999.

Granning® Air Suspensions was founded in 1949 in Detroit, Michigan. Granning's product line was consolidated under Fluidrive, Inc. in 1985.

Reyco® was founded in 1924 as Reynolds Mfg. Co. and assumed the Reyco® Industries, Inc. name in 1956 in Springfield. Reyco® Canada began at the current location in Grimsby, Ontario in 1963. The Mt. Vernon facility was established in 1973.

ReycoGranning® air and steel spring suspension systems are sold to truck, trailer, and specialty vehicle OEM's, and to truck equipment distributors. Tuthill Transport Technologies design, test, manufacture and market these products.

Tuthill Transport Technologies is certified to the internationally recognized ISO 9001 Standard. This certification includes ReycoGranning® operations.

ISO 9001 is the highest international quality standard and is recognized worldwide by all major countries and corporations. To obtain certification a company must undergo a series of rigorous audits to remain certified and ensure consistent quality standards are being maintained. This quality standard was developed by the International Organization of Standardization.

Tuthill Corporation is a privately held manufacturing company with over 3,000 employees and facilities on five continents. Tuthill's corporate offices are located in Burr Ridge (Chicago), Illinois.

SAFETY PROCEDURES & INFORMATION	○ i.1
SAFETY FIRST	○ i.1
OPERATOR SAFETY	○ i.1
Lifting	○ i.1
Parts Handling	○ i.1
Welding	○ i.1
SUSPENSION SAFETY	○ i.2
Overloading the suspension	○ i.2
Torque	○ i.2
HANGER INFORMATION	○ i.3
HANGER INSTALLATION	○ i.4
WELDING INSTRUCTIONS FAB HANGERS	○ i.6
AXLE SEAT INSTALLATION	○ i.7
TORQUE ARM BUSHING ASSEMBLY INSTALLATION	○ i.9
AXLE TO HANGER ASSEMBLY INSTALLATION	○ i.11
SUSPENSION ALIGNMENT INSTRUCTIONS	○ i.12

Installation Instructions Model 21B

SAFETY FIRST

Be sure to read and follow all installation and maintenance procedures.

LIFTING

Practice safe lifting procedures. Consider size, shape and weight of assemblies. Obtain help or the assistance of a crane when lifting heavy assemblies. Make sure the path of travel is clear.



PARTS HANDLING

When handling parts, wear appropriate gloves, eyeglasses and other safety equipment to prevent serious injury.

WELDING

When welding, be sure to wear all personal protective equipment for face and eyes, and have adequate ventilation. When welding, protect spring beams and air springs from weld spatter and grinder sparks. Do not attach "ground" connection to springs.

Under normal use, steel presents few health hazards. Prolonged or repeated breathing of iron oxide fumes produced during welding may cause siderosis.

NOTE: DO NOT WELD ADI Components.

Welding Helmet

Welding Apron

Welding Gloves

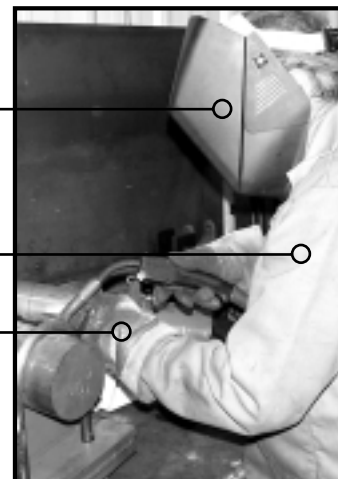

 **WARNING**

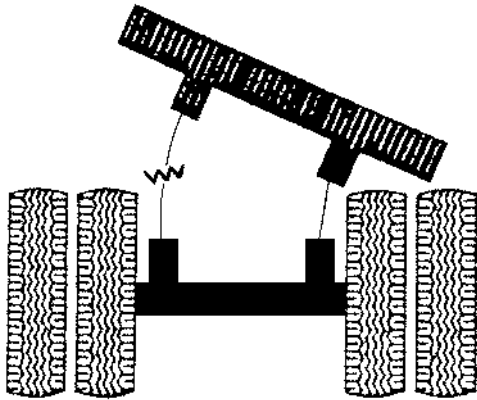

OVERLOADING

Overloading is the practice of transporting cargos that surpass the specified vehicle's ratings. Overloading can cause component failure, resulting in accidents and injuries.



This symbol indicates to the reader to use caution when seen and to follow specific requirements or warnings stated.



CAUTION: Specific torque requirements are recommended.

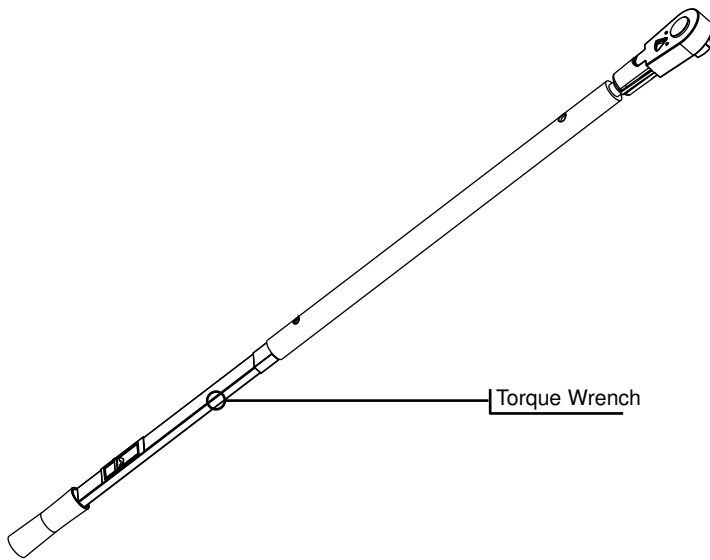

TORQUE

Proper tightening of the U-bolt nuts and alignment bolts are high priority items. A fastener system is considered "loose" any time the torque is found below required values. Failure to maintain the specified torque and to replace worn parts can cause component failure resulting in accident with consequent injury.

NOTE: It is extremely important after the first 1,000 to 3,000 loaded miles (1,600 - 4,800 kms) of operation, and with each annual inspection thereafter, that all of the bolt and nut tightening recommendations be followed. Any loose fasteners must be retorqued to comply with warranty requirements and to ensure long, trouble-free performance.

Installation Instructions Model 21B

HANGER INSTALLATION

Based on your axle spread requirement, determine the hanger center to center dimension, from drawings on pages **m.7** to **m.16**. Then, on the subframe, mark the centerline of the equalizer hanger (item 6) from the king pin. Typical axle spacing shown at right.

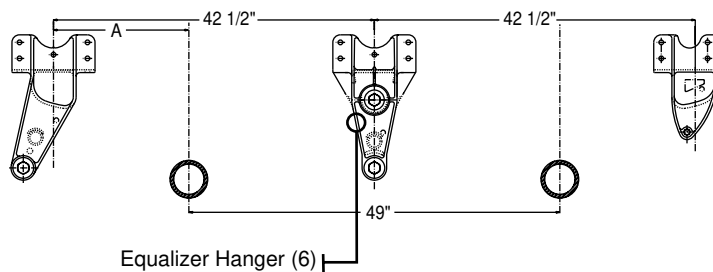

Cast hanger drawings (**i-5**) and Fab hanger drawings (**i-6**) provide typical detailed requirements for hanger installations. Before proceeding, please refer to these drawings for trouble-free maintenance.

From the equalizer locate the center line of the front (item 1, 2) and rear hangers (item 14, 15). Clamp the hangers in position. If bolt-on design is used, match-drill hole pattern of hangers and install fasteners. If weld-on design is used, tack weld hangers to sub-frame. Be sure the brackets are secure in both the horizontal and vertical planes and that the hangers are square in the frame. Hanger centers should be in line within 1/16". See pages **m.7** to **m.16** for proper spacing.

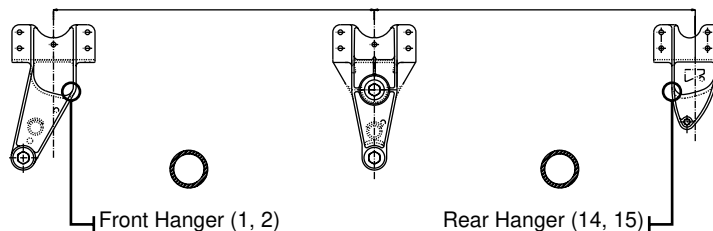

When bolting hangers to frame, use grade 8 hardware. When welding hangers to frame use AWS 70S wire or AWS E7018 electrode specifications for proper results see page **i.6**. Add 1.5" schedule 80 pipe cross tube steel pipe braces to front and center hangers.



CAUTION: Specific welding procedures are required for installation.

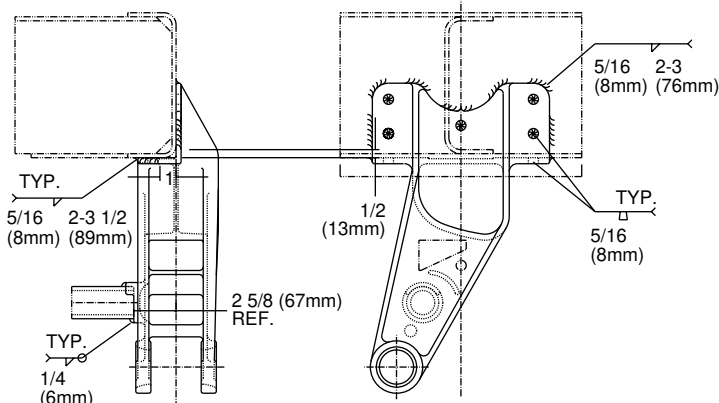
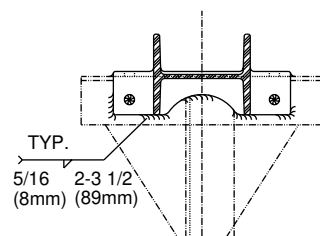

AWS Electrode Specification

- 1. Shielded Metal Arc (stick electrodes)E7018
- 2. Gas Metal Arc (MIG, solid wire)ER70S-X
- 3. Gas Tungsten Arc (TIG)ER70S-X
- 4. Flux Cored Arc (tubular wire).....E70T-X

INSTRUCTIONS FOR WELDING SUSPENSION HARDWARE TO FRAMES AND AXLES

Four methods may be used to weld components per American Welding Society (AWS) specifications.

NOTE: DO NOT WELD ADI Components.

The weld strength must be at 70,000 psi. Higher or lower strengths are not acceptable. The best fusion and strengths will be obtained using the voltage, current, and shielding medium recommended by the electrode manufacturer. If stick method is used, electrodes must be clean and dry, and stored per AWS Section 4.5.2.

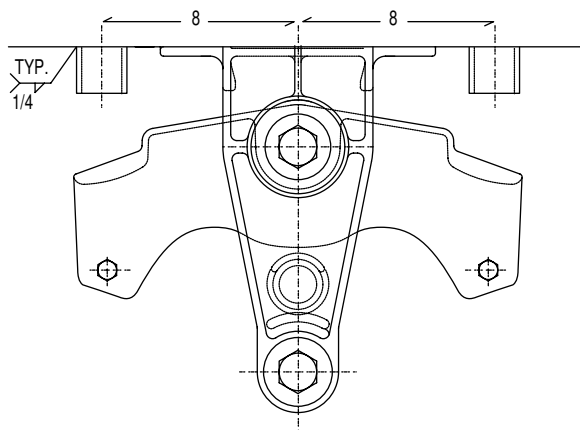

OPTIONAL UNDERFRAME BUMP STOP

An underframe bump stop is available to be welded to the frame. The part number is 24695-01 or as a kit, K700073 for one equalizer and TK4722 for 2 equalizers. See the diagram below for proper installation.

TRI-AXLE

Bump stops for multi-axle suspensions are highly recommended and are available as an option for tandem application.

NOTE: DO NOT WELD ADI Components.

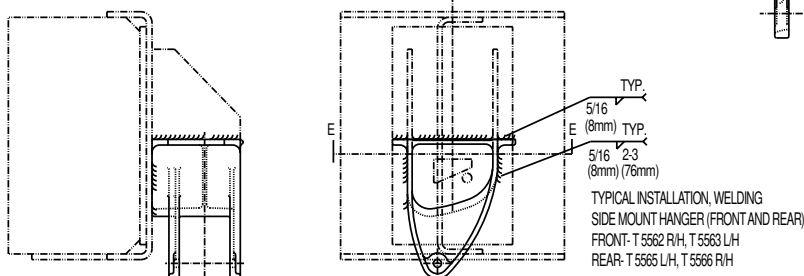
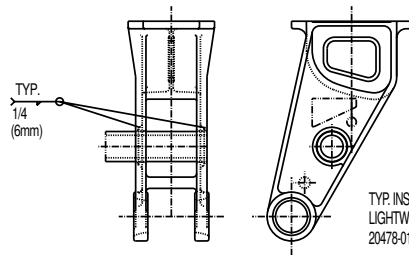
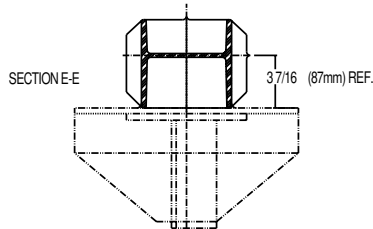
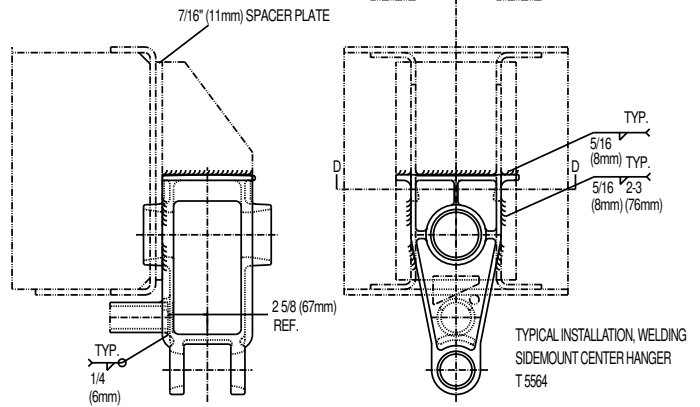
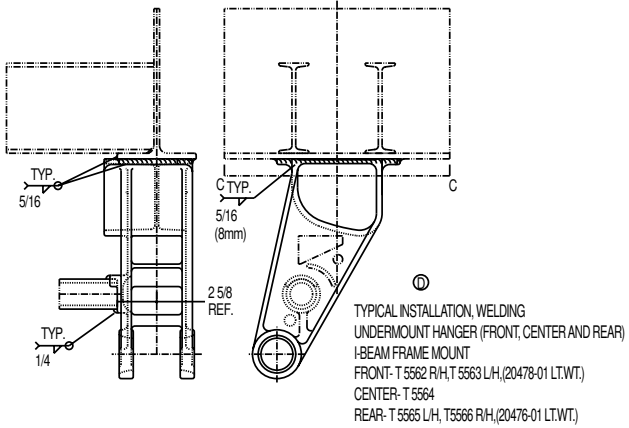
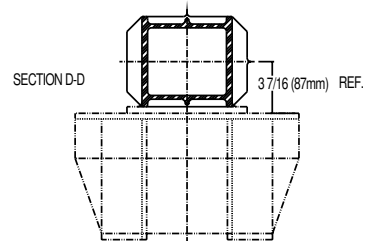
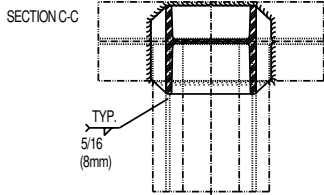
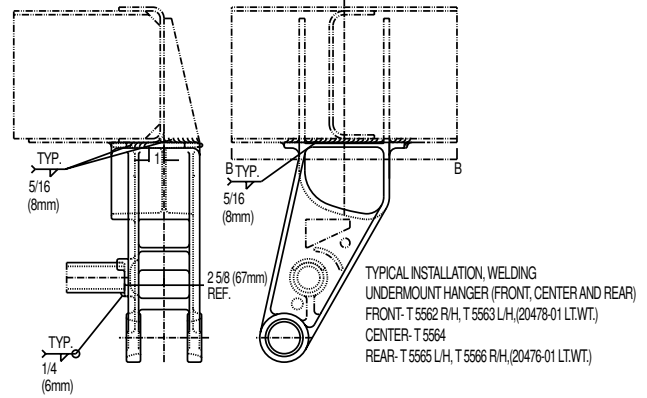
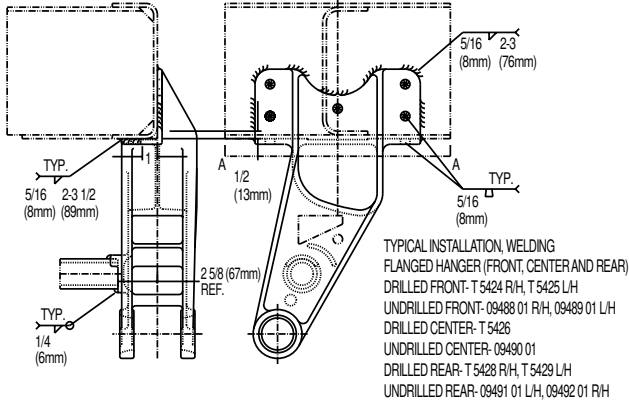
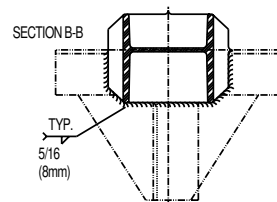
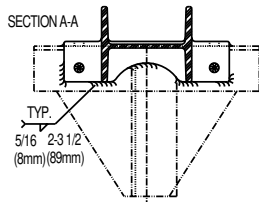

**WELDING INSTRUCTIONS
FABRICATED HANGERS**

1. Use AWS E7018 rod or equal for all welds.
2. Bracing shown is the minimum requirement. Heavy duty use may require additional bracing. Contact Tuthill Transport Technologies for more information.
3. Pipe bracing shown is 1 1/2" (nom.) schedule 80 pipe.
4. Use 1/4" material for all gussets
5. If spring center line does not line up with center line of frame I-beam, adjust gusseting so that gussets extend to edges of top plate on all hangers.
6. Pipe brace between rear hangers is not necessary unless suspension is subjected to heavy-duty use.

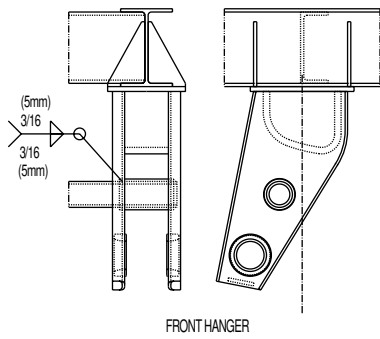

FRONT HANGER

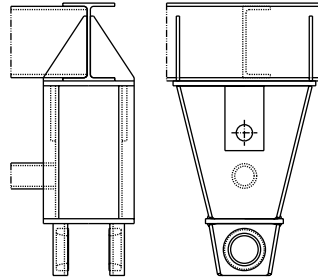

CENTER HANGER
50 INCH TO 65 INCH AXLE SPACING

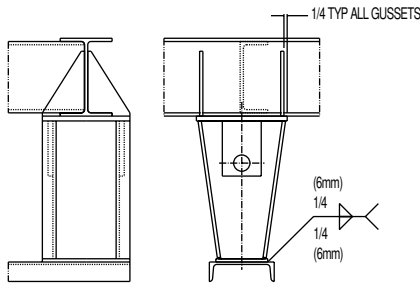

CENTER HANGER
72 INCH TO 100 INCH AXLE SPACING

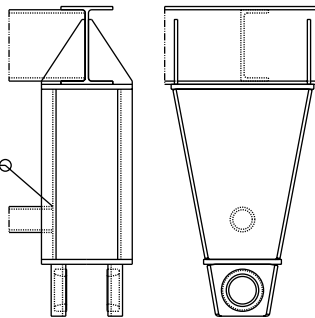

TORQUE ARM ATTACHMENT BRACKET
OPTIONAL FRONT EQUALIZER GUIDE TYPICAL

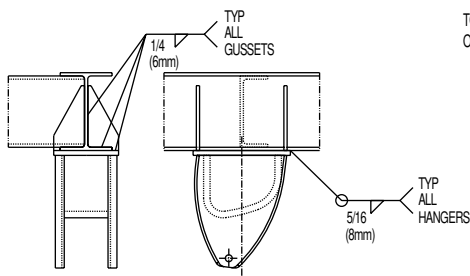

REAR HANGER

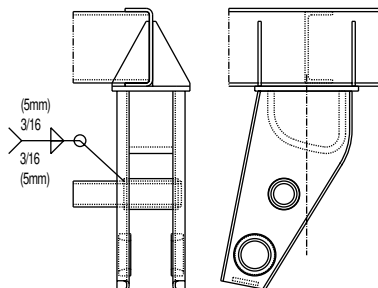

FRONT HANGER
INSTALLATION ON C-CHANNEL FRAME
TYPICAL FOR ALL HANGERS

Installation Instructions Model 21B

BRAKE CAM LOCATION REQUIREMENTS

Brake camshafts are located to the rear of the axle within 20° of centerline. If camshafts are located differently, assembler must check for adequate clearances. Be sure that the axle seats which are selected provide brake chamber and brake camshaft assembly clearances. Location recommended is on center to 20° below center line.

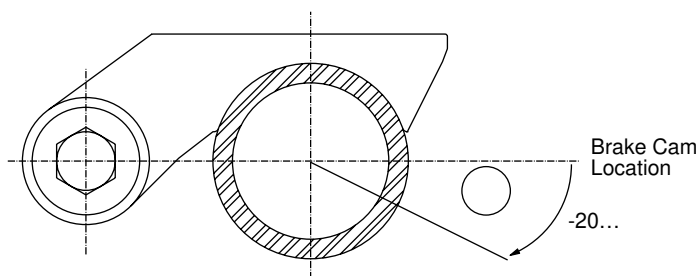

AXLE ASSEMBLY INSTALLATION

Position the axle seats (item 20) on the axle at the correct spring center spacing (same as the transverse distance between hanger centerlines as mounted to the sub-frame). The centerline of the spring bolt hole must pass through the axle camber line and the spring surface of the seats must be parallel to the ground. Clamp the seats in position securely and tack weld front and rear (not on the axle camber line).

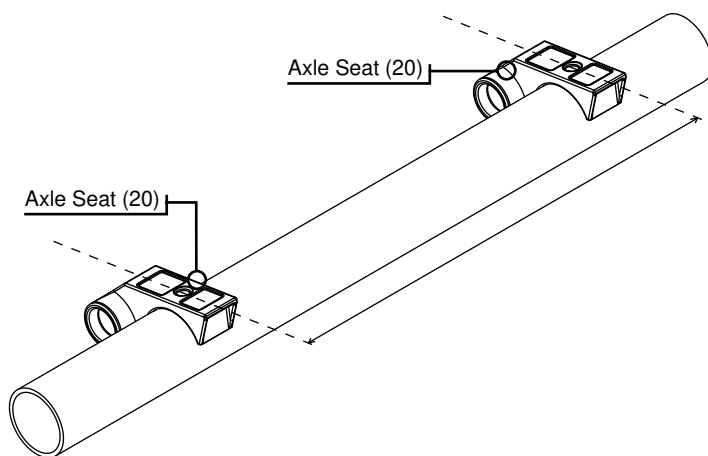

Weld the axle seat to the axle. Electrode must meet or exceed the requirements of AWS E7018. Do not weld 1 1/2" (38.1 mm) each side of the axle center line. At this point, the spring beams and u-bolts should not be attached to the seat.

NOTE: Refer to diagrams on page i.7 for welding detail.



CAUTION: Specific torque requirements are recommended.

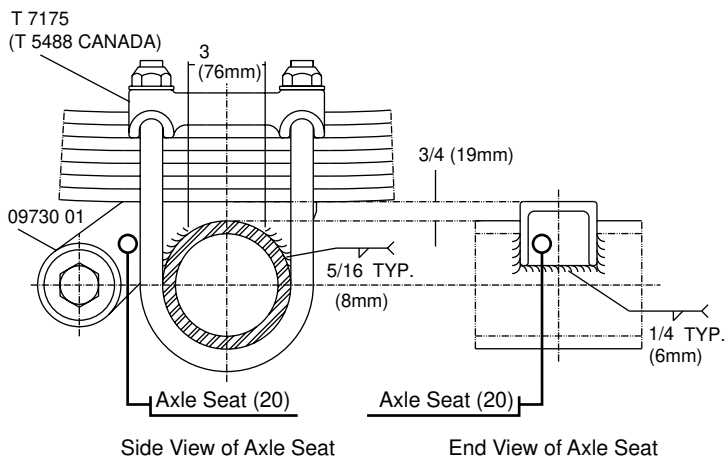

Position spring (item 13) on axle seat. See installation drawings (at end of book) for proper location of spring hook ends. Secure the spring in place with the top plate, u-bolts and nuts (items 5, 29 & 3) provided. Recheck springs for proper spring spacing and alignment. Tighten 3/4" or 7/8" u-bolts to 300-325 FP (410-440 NM) torque.

NOTE: Spring liners (additional) needed on the top side only on all 1-, 2- & 3-leaf springs. If axle seat spacers are used they must be welded to axle seat, front and rear.



CAUTION: Specific torque requirements are recommended.

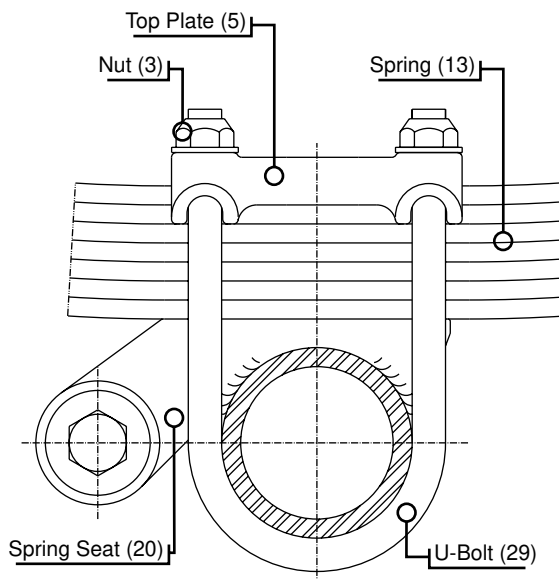

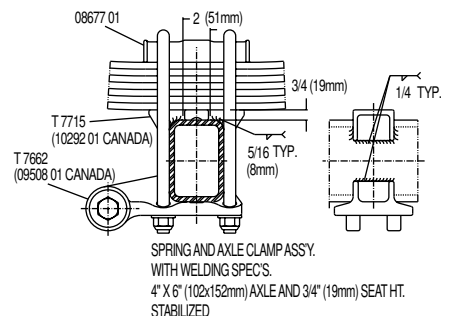
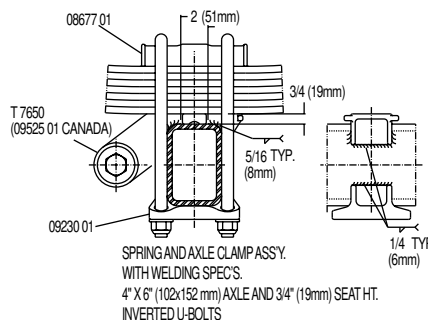
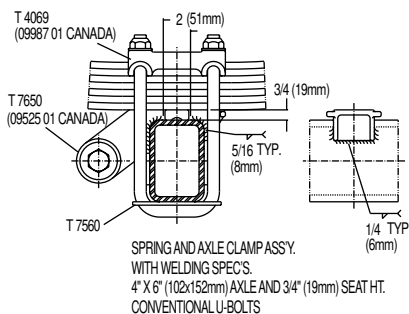
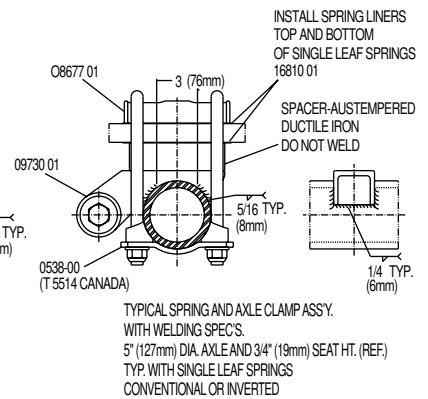
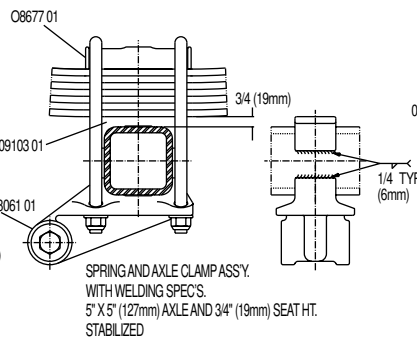
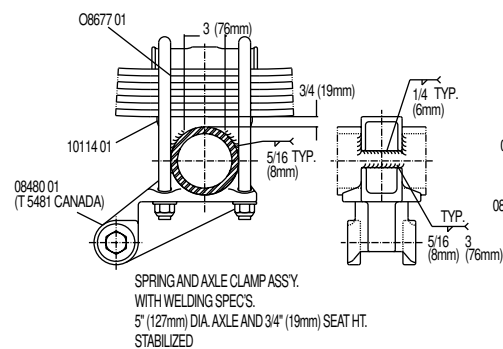
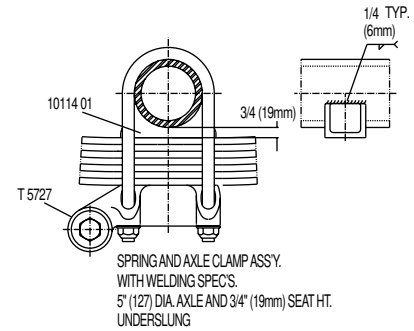
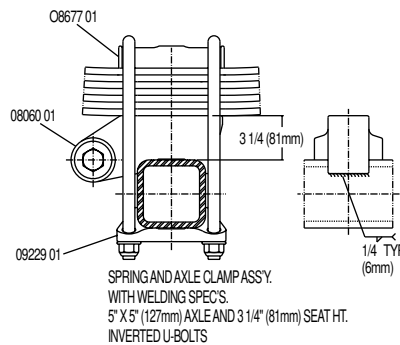
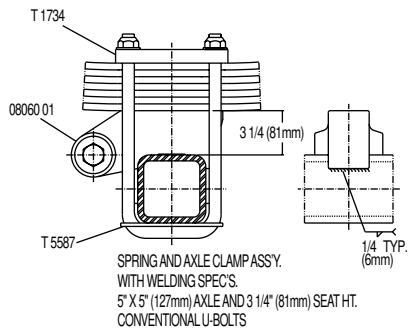
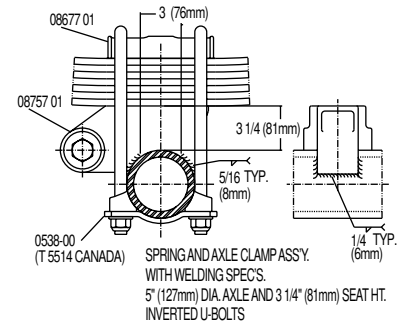
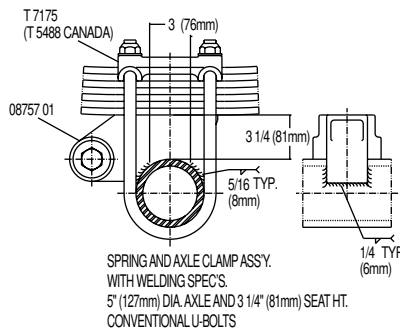
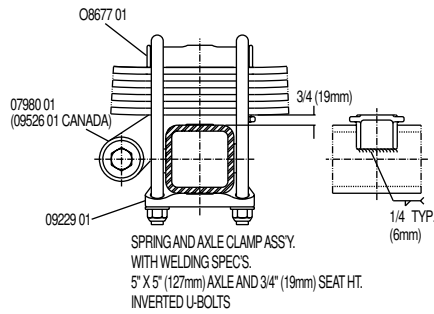
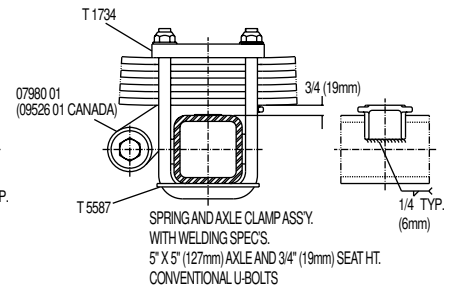
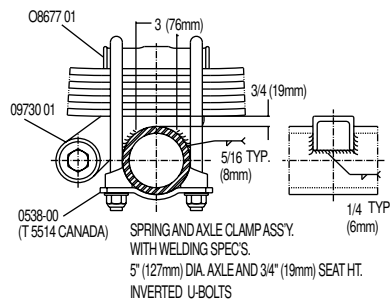
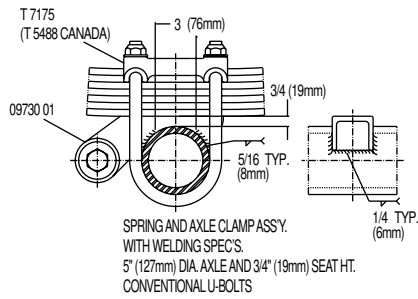

NOTE: LOW HYDROGEN WELDING ROD E-7016 OR EQUAL IAS RECOMMENDED.

Installation Instructions Model 21B

TWO-PIECE TORQUE ARM BUSHING ASSEMBLY PROCEDURE

Place Compression Washer and Rubber Bushing on head of Torque Arm bolt, and insert through openings in Hanger and through Torque Arm end opening. Lubricants ARE NOT recommended, but if absolutely necessary, use soap and water, or just plain water.

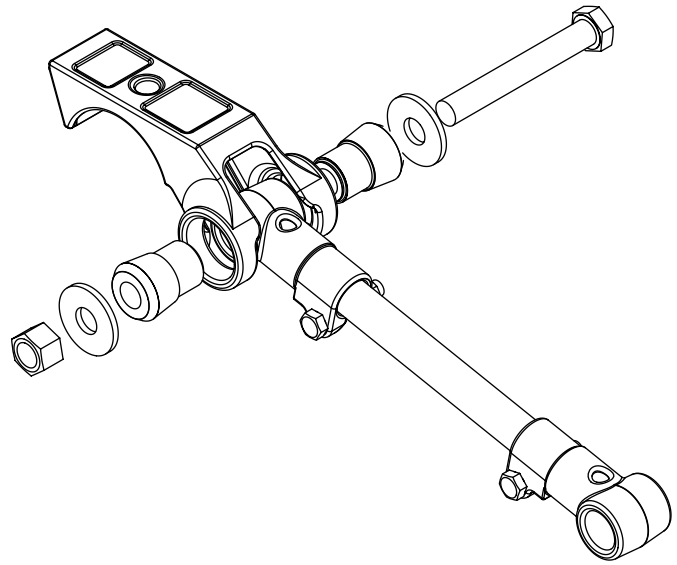

Do not use any Petroleum-Based Lubricants.

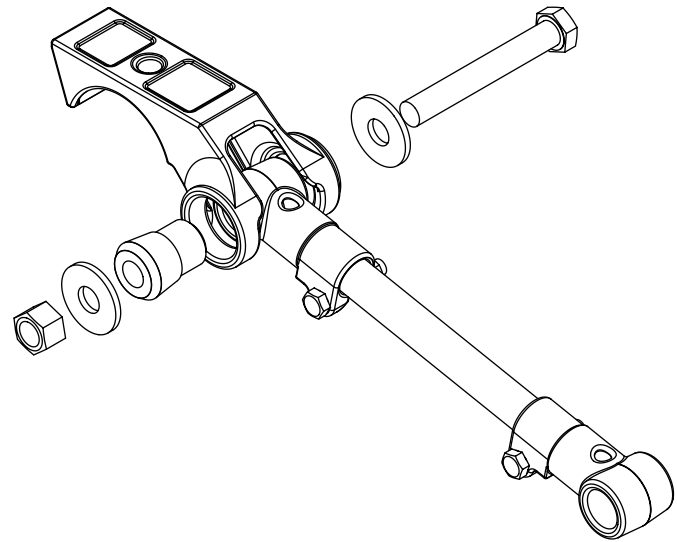

Place second Bushing, and second Compression Washer on other end of Torque Arm Bolt. Start Nut on Bolt by hand.

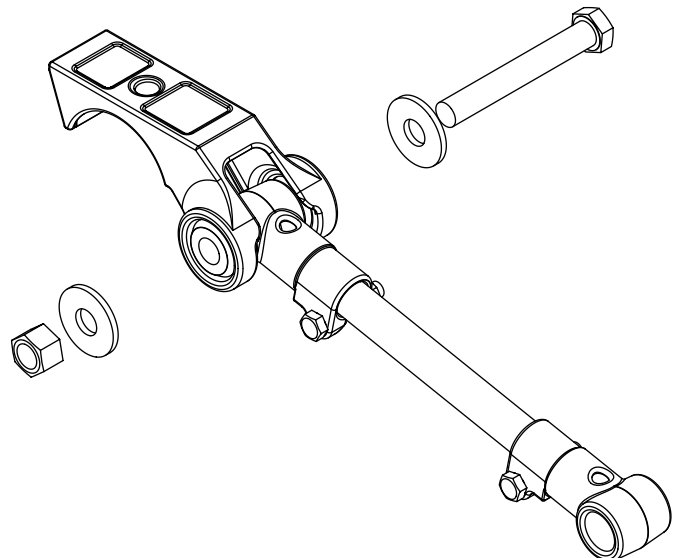

Tighten nut, partially, until all air gaps are removed between the two Compression Washers. Roughly center and hold the Torque Arm in the middle of the Hanger gap.

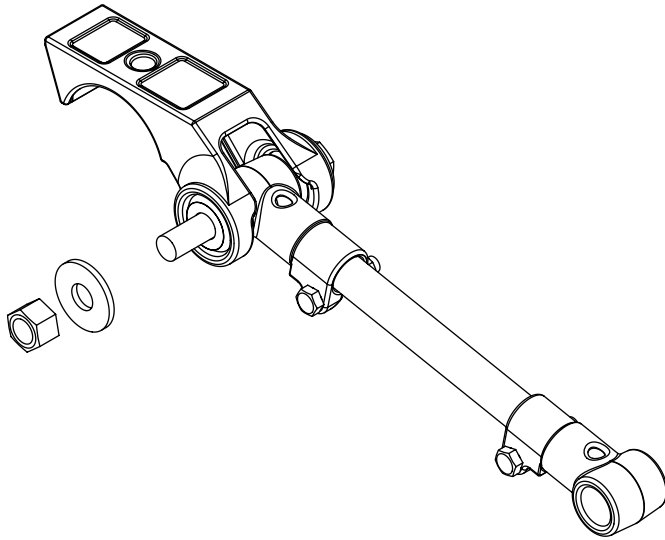

Slowly bring up the torque on the Locknut to 140-160 ft. lbs. (190-220 Nm) There should be an even buildup of rubber beads on each side of the Torque arm, and on each side of the Compression Washers. If the rubber is not built up, or if the Torque Arm is not centered, it is recommended to redo the above steps.

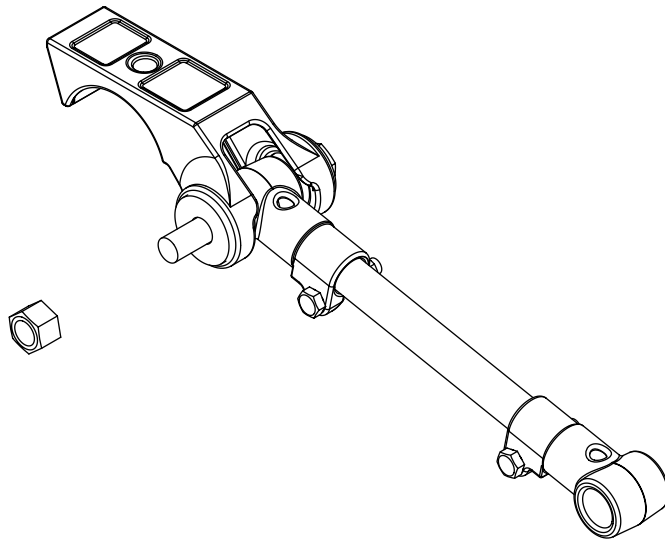

Do not keep tightening the nut, once the assembly is completed.

A subsequent check of the torque on the nut will be lower than 140 ft. lbs. (190 Nm). because of rubber settling. Make sure the assembly is snug and that there are no air gaps between washer, hangers and rubber bushings.

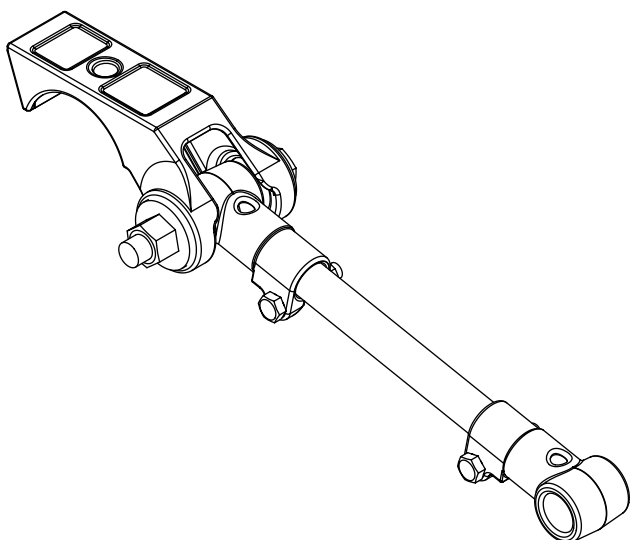

Installation Instructions Model 21B

AXLE TO HANGER ASSEMBLY INSTALLATION AND PRELIMINARY ALIGNMENT

Position the axle and spring assembly between the hangers. Secure the torque arms (adjustable on road, left side, item 30 or 31) and rigid on curb, right side, item 26 or 27) to the front (item 1 or 2) and center hangers (item 6). Install the spring rollers (item 19) and 1/2" bolts in the equalizer and where required in the rear hanger (item 14, 15).

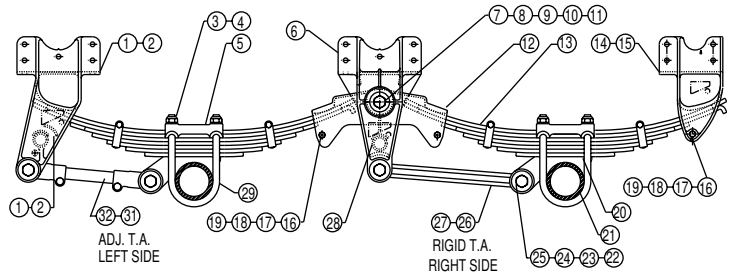

Check to see that springs are seated, interference-free, on all bearing surfaces. Install bolts to hold torque arms. **DO NOT TORQUE** at this time.

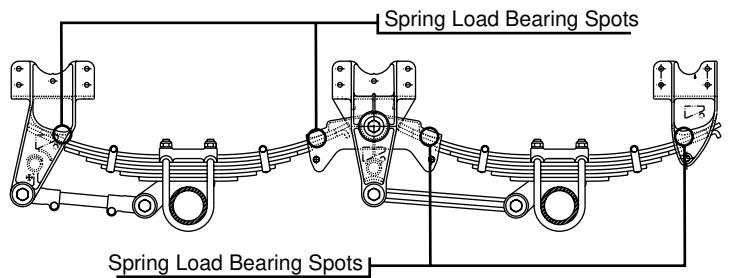

Install and tighten the 5/8" adjustable torque arm clamp nuts finger tight.

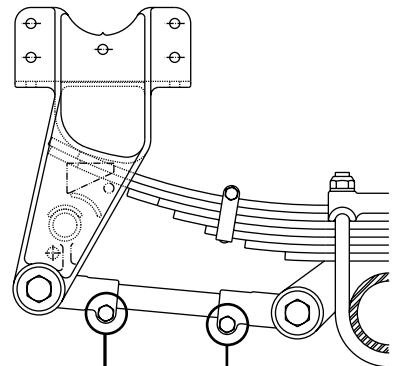

Adjustable Torque Arm Clamp Nuts

NOTE: Refer to appropriate drawing for axle number and type to identify proper item numbers.



CAUTION: Specific torque requirements are recommended.

Position the frame at the desired mounting height and perform preliminary rough alignment by centering axle laterally, and aligning axles squarely with respect to frame to within 1/4" (6.4 mm) (right and left compared). Torque arm attaching 1" bolts and nuts (supplied with the torque arms item 22 & 23) can now be torqued to 140-160 ft. lbs. (190-220 Nm). Do not tighten the adjustable eye end clamp bolts at this time. See next page.

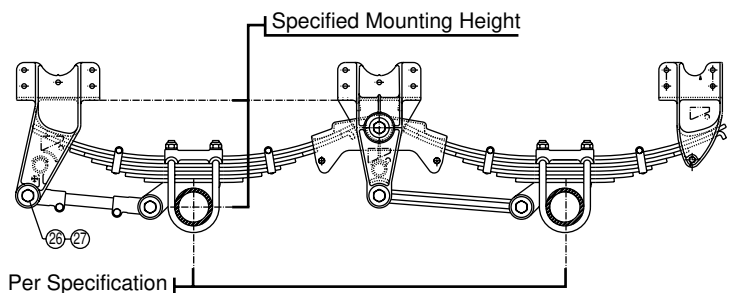

**FINAL AND IN SERVICE
SUSPENSION ALIGNMENT
INSTRUCTIONS**

The following steps are recommended and necessary for proper suspension alignment.

Release the brake system and pull the trailer forward while keeping to a straight line to free the suspension from binding. The ground must be level and smooth.

For best results the use of axle extensions and a "BAZOOKA" type king pin post, or a suitable optical alignment device are recommended. Align the front axle by lengthening or shortening adjustable torque arm (located on left side of trailer) with the king pin as shown in the sketch.

When the axles are aligned to +/- 1/8" tighten the 5/8" torque arm clamp nuts on the front axle to 125-150 FP (170-205 Nm).



CAUTION: Specific torque requirements are recommended.

Align the rear axle with the front axle to +/- 1/16".

NOTE: Left side and right side axle measurements should be equal to within +/- 1/16". When the axles are aligned, tighten the adjustable torque arm clamp nuts on the rear axle to 125-150 FP (170-205 Nm).



CAUTION: Specific torque requirements are recommended.

After an initial loaded run-in period of approximately 1,000 miles, (1600 km) the alignment should be rechecked and corrected if necessary.

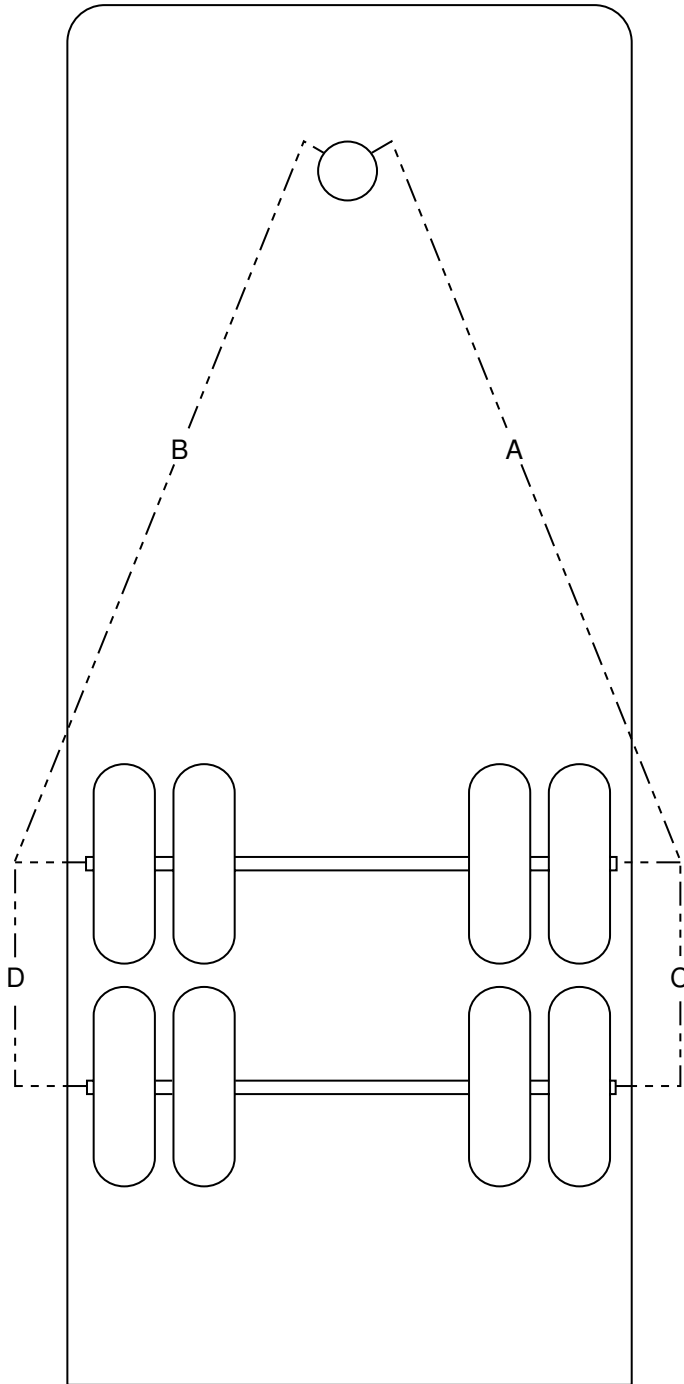

A = B +/- 1/8
C = D +/- 1/16

FP = Foot-Pounds; Nm = Newton-Meters

CAST HANGERS MAINTENANCE SCHEDULE ○ m.1

Maintenance Schedule ○ m.1

Torque Requirements ○ m.1

Visual Inspection ○ m.1

FAB HANGERS MAINTENANCE SCHEDULE ○ m.2

Maintenance Schedule ○ m.2

Torque Requirements ○ m.2

Visual Inspection ○ m.2

TROUBLE SHOOTING GUIDE ○ m.3

Fasteners ○ m.3

Spring Alignment ○ m.3

Bushings ○ m.3

COMPOSITE SPRING ○ m.4

BILL OF MATERIAL ○ m.5

63159-2 ○ m.6

Bill of material ○ m.7

SUSPENSION DRAWINGS ○ m.8

98034-2 & 3 ○ m.8

63296-2 & 66128-2 ○ m.9

63159-2 & 3 ○ m.10

98033-2 & 63159-1 ○ m.11

74117-2 & 70100-2 ○ m.12

87188-2 & 83006 ○ m.13

84164 & 87187-2 ○ m.14

73129-2 & 74021 ○ m.15

84101 & 83005 & 84166 ○ m.16

LIMITED WARRANTY ○ m.17

Product Installer Responsibilities ○ m.17

Product Owner Responsibilities ○ m.18

Warranty Claim Procedures ○ m.18

Maintenance Instructions Model 21B

MODEL 21B MAINTENANCE INSTRUCTIONS (CAST HANGERS)

The ReycoGranning Model 21B Leaf Spring Suspension, by design requires minimum maintenance. Suspensions require periodic checks to assure continued trouble-free performance.

21B RECOMMENDED MAINTENANCE SCHEDULES

1. Pre-service inspection.
2. First service inspection, after 1,000-3,000 miles, (1600-4800 KM).
3. PM Inspections, coincidental with DOT "C" Inspections-Annually.
4. During replacement of any service parts.
5. Upon discovery of any loose components.

TORQUE REQUIREMENTS

Verify with each scheduled inspection.

1. Tighten 3/4" or 7/8" U-bolt nuts—300-325 FP, (410-440 Nm).
2. Tighten 1" torque arm end nuts—140-160 FP, (190-220 Nm)
3. Tighten 5/8" torque arm clamp nuts—125-150 FP, (170-205 Nm).
4. Tighten 1" equalizer capscrews—400-450 FP, (540-610 Nm).
5. Tighten 1/2" spring retainer nuts—75-80 FP, (105-110 Nm).

VISUAL INSPECTION

1. Loose or missing fasteners.
2. Cracks in hangers or axle connection brackets.
3. Springs, centered in hangers and equalizers.

If any of the above defects are noted, have vehicle checked by a qualified mechanic. Torque values are specified with clean, lightly oiled fasteners, and should only be verified with a calibrated torque wrench. Failure to follow these instructions could void the warranty and could result in subsequent injury.

FP = Foot-Pounds; Nm = Newton-Meters

MODEL 21B MAINTENANCE INSTRUCTIONS (FAB HANGERS)

The ReycoGranning Model 21B Leaf Spring Suspension, by design requires minimum maintenance. Suspensions require periodic checks to assure continued trouble-free performance.

21B RECOMMENDED MAINTENANCE SCHEDULES

1. Pre-service inspection.
2. First service inspection, after 1,000-3,000 miles, (1600-4800 KM).
3. PM Inspections, coincidental with DOT "C" Inspections-Annually.
4. During replacement of any service parts.
5. Upon discovery of any loose components.

TORQUE REQUIREMENTS

Verify with each scheduled inspection.

1. Tighten 3/4" or 7/8" U-bolt nuts—steel springs—300-325 FP, (410-440 Nm).
2. Tighten 3/4" or 7/8" U-bolt nuts—composite springs—250 FP, (340 Nm).
3. Tighten 11/4" equalizer shaft fastener nuts—575-625 FP, (780-850 Nm).
4. Tighten 21/2" equalizer shaft fastener nuts—F.W.WB 54"-65 1/2" —300-325 FP, (410-440 Nm).
5. Tighten 11/2" equalizer shaft fastener nuts—F.W.WB 72"-109" —200-225 FP, (270-305 Nm).
6. Tighten 1" torque arm bolt nuts—140-160 FP, (190-220 Nm).
7. Tighten 5/8" torque arm clamp nuts—125-150 FP, (170-200 Nm).
8. Tighten 3/4" torque arm clamp nuts—175-200 FP, (236-270 Nm).
9. Tighten 1/2" spring retainer nuts—60-80 FP, (80-110 Nm).

VISUAL INSPECTION

1. Loose or missing fasteners.
2. Cracks in hangers or axle connection brackets.
3. Springs, centered in hangers and equalizers.

If any of the above defects are noted, have vehicle checked by a qualified mechanic. Torque values are specified with clean, lightly oiled fasteners, and should only be verified with a calibrated torque wrench. Failure to follow these instructions could void the warranty and could result in subsequent injury.

FP = Foot Pounds, Nm=Newton/Meters

Maintenance Instructions Model 21B

FASTENERS

Loose fasteners need immediate attention. Check components for wear and be sure holes are not worn or egg shaped. When replacing, be sure threads are clean, lightly oiled and not deformed. Consult the maintenance section for the correct torque specification. To insure an accurate torque reading, the torque tool used for checking torque, must provide a correct measurement.

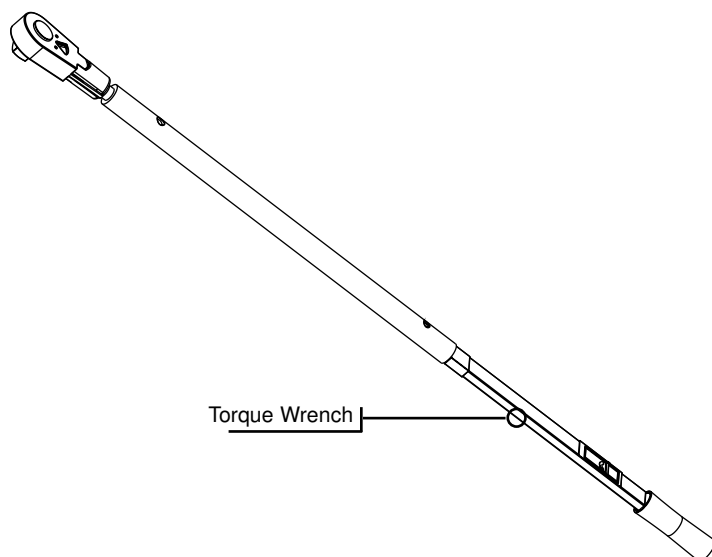

BUSHINGS

Inspect rubber bushings for large splits, tears and major wear. Rubber is attacked by sun, oils and greases. Replace any bushings which have noted damage.

Use a non-petroleum rubber lubricant, water or soap and water.

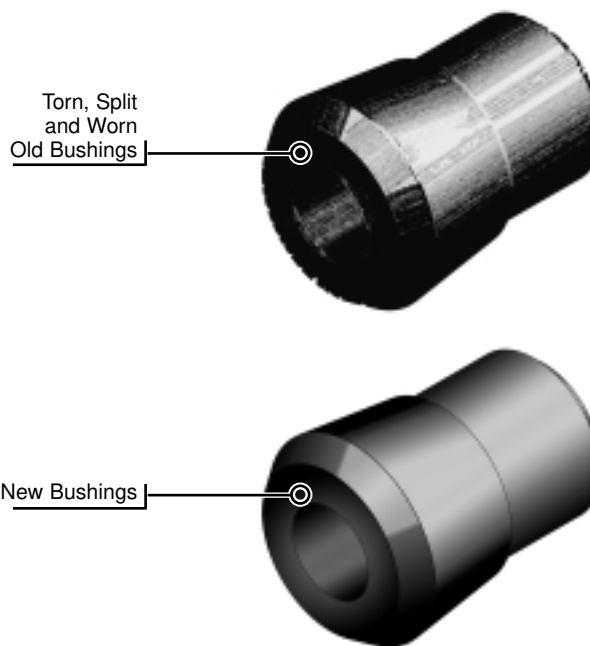

MAINTENANCE KIT

The following item numbers will help when maintaining parts for the model 21B suspension.

TK18997 - Torque Arm Rebush Kit - 21B (1) End

TK18998 - Equalizer Rebush Kit - 21B (1) Equalizer

TK24125 - Two Wear Pad Kit (wm hm) - 21B (1) Hanger

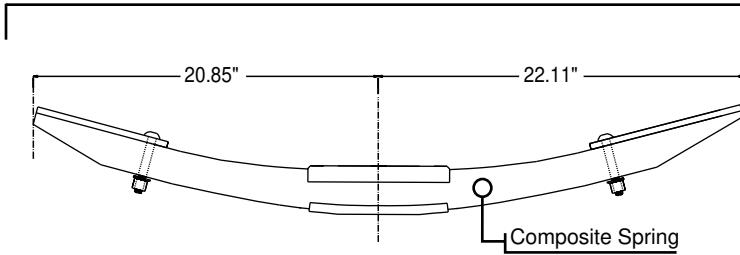

"Liteflex" Composite Spring

MODEL 21B COMPOSITE SPRING INFO.- "LITEFLEX"

When Delphi's "Liteflex" composite springs are substituted for steel springs in the Model 21B several critical characteristics change. TTT includes the instructions for specific applications in the axle seat kit. If you do not have these instructions available to you, please contact TTT Customer Service Department for an additional copy. Listed below is an overview of items that are special to composite springs:

MODEL 21B COMPOSITE SPRING

- Delphi's "Liteflex" composite spring can only be used in over-slung, single or tandem applications, with inverted (round end up) or conventional U-bolts.
- Mounting heights are limited to a maximum of 17" for standard configurations. No-hop configurations are limited to a maximum of 16".
- Do not use a fabricated top plate. Use only the cast top plate (p/n 0867701) furnished in the axle seat kit.
- Torque arm lengths and rebound bolt placement may vary. Refer to the instruction sheet that is specific to your application.
- Reduced free-play bushings interfere with spring movement. Severe damage will occur to your suspensions if composite springs are installed with this option.
- U-bolt torque value is reduced to 250 FP (340 Nm) and must be achieved through a 50 FP (70 Nm) alternating procedure.
- "Liteflex" composite springs cannot be used in conjunction with ReycoGranning's heavy duty hanger option.
- Repeat the torque procedure after the first 1,000 loaded miles.

Delphi's "Liteflex" composite spring is not included in the TTT 5 Year/500,000 Mile Limited Warranty when furnished as original equipment on your new trailer. If purchased separately, these springs are covered by a 1-Year Limited Warranty. To ensure coverage under warranty provisions, the springs must be installed and maintained following the above procedures. Damage from misuse, misapplications, lack of maintenance, or heat sources are not included in the warranty. Please contact TTT Customer Service for further details.

FP = Foot-Pounds; Nm = Newton-Meters

Drawing No. 63159-2 Parts List					
ITEM	PART NUMBER	Single Axle	Tandem Axle	Tri-Axle	DESCRIPTION
1	T5424	1	1	1	Front Hanger, Right
2	T5425	1	1	1	Front Hanger, Left
3	1434501	8	16	24	Lock Nut 7/8"
4	T7292	8	16	24	Washer 7/8"
5	Variable*	2	4	6	Top U-bolt Plate
6	T5426	0	2	4	Center Hanger
7	1424801	0	4	8	Equalizer Bolt 1"
8	1425001	0	4	8	Lockwasher 1"
9	1424901	0	4	8	Equalizer Compression Washer
10	T5524	0	4	8	Equalizer Bearing
11	1424701	0	2	4	Equalizer Shaft
12	T5427	0	2	4	Equalizer
13	Variable*	2	4	6	Spring
14	T5428	1	1	1	Rear Hanger, Right
15	T5429	1	1	1	Rear Hanger, Left
16	T5544	2	6	10	Cap Screw 1/2" x 4 3/4"
17	T1704	2	6	10	Hex Nut 1/2"
18	T1705	2	6	10	Lockwasher 1/2"
19	T2106	2	6	10	Spring Roller
20	Variable*	2	4	6	Axle Seat
21	Not Furnished				Axle
22	T5492	4	8	12	Torque Arm Bolt
23	T5495	4	8	12	Lock Nut 1"
24	T2224	8	16	24	Torque Arm Washer
25	T5493	8	16	24	Torque Arm Bushing
26	T7635	1	1	1	Torque Arm Rigid, Front 16 1/4" Curb Side
27	T2293	0	1	2	Torque Arm Rigid, Rear 18 7/8" Curb Side
28	Not Furnished				Pipe Brace
29	Variable*	4	8	12	U-Bolt
30	T5485	1	1	1	Torque Arm Adjustable, Front 16 1/4" Road Side
31	T5486	0	1	2	Torque Arm Adjustable, Rear 18 7/8" Road Side

* NOTE: Variables are listed on tables-on page 18.

SPRING SELECTION TABLE				
PART NO.	# LEAF	ARCH	CAPACITY	LENGTH
0837601	3	Med.	11,000	42
1260901	7	Med.	9,000	42 1/2
1563601	1	Med.	12,500	42
1890601	9	Med.	9,000	55
2001601	Comp.(1)	Med.	11,000	41 3/4
2151101	3	Med.	12,500	42
T3086	7	Med.	9,000	42 1/4
T3564	8	Med.	11,000	42 1/4
T5547	7	High	9,000	42 1/2
T5555	1	Med.	11,000	42 1/10
T5592	8	Low	11,000	42 1/2
T5597	8	High	11,000	42 1/2
T7297	1	Med.	11,000	36 1/2
T7321	1	High	11,000	42.18
T7452	9	Med.	13,000	41 3/4
18308-01	10	Med.	14,250	41 3/4

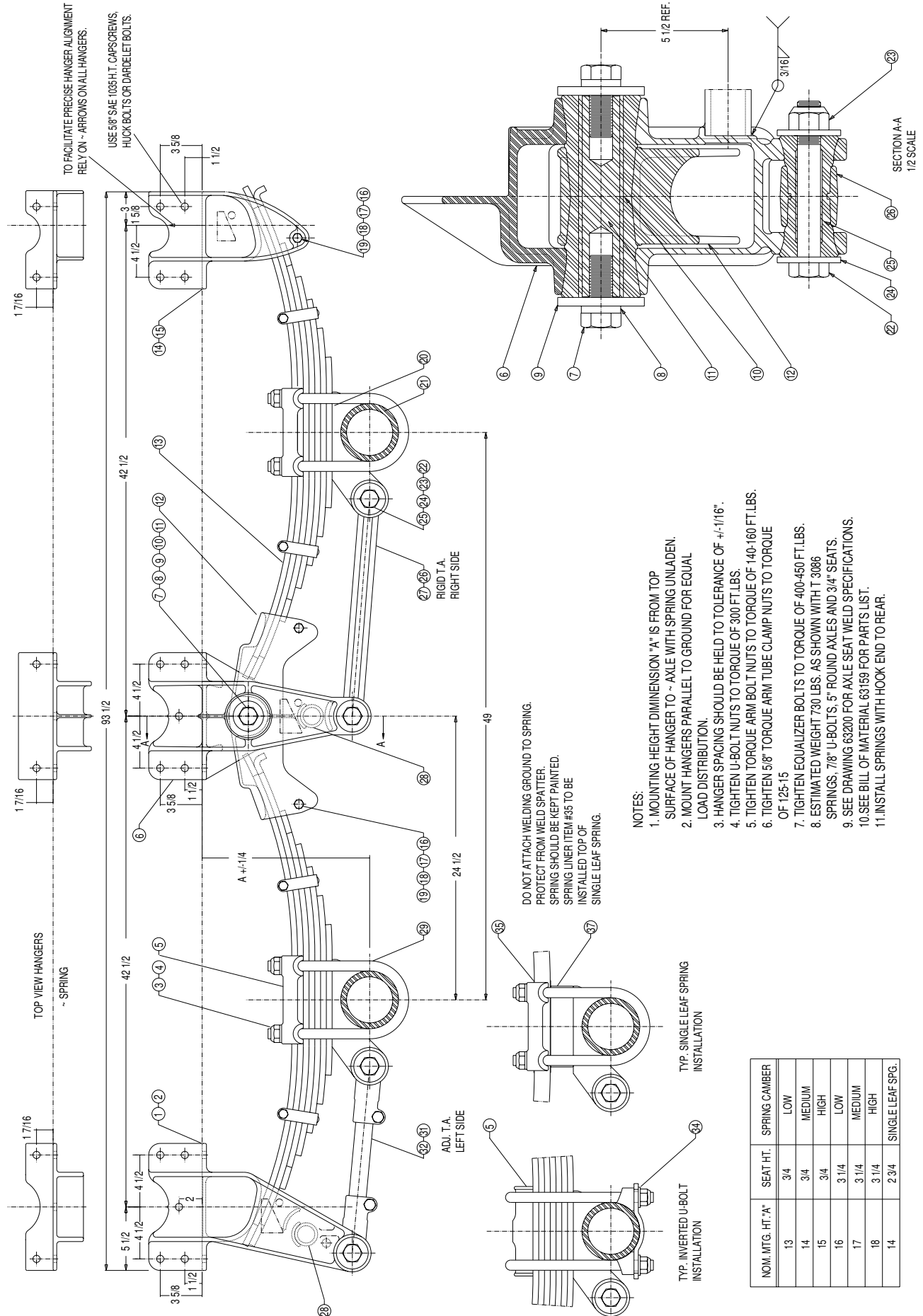

NOM. MTG. HT. "A"	SEAT HT.	SPRING CAMBER
13	3/4	LOW
14	3/4	MEDIUM
15	3/4	HIGH
16	3 1/4	LOW
17	3 1/4	MEDIUM
18	3 1/4	HIGH
14	2 3/4	SINGLE LEAF SPG.

U-BOLT SELECTION TABLE					
LENGTH	PART NO.	LENGTH	PART NO.	LENGTH	PART NO.
11 1/2"	24213-115	13 1/2"	24213-135	15"	24213-150
12 1/2"	24213-125	14"	24213-140	16"	24213-160
13"	24213-130	14 1/2"	24213-145	17 1/2"	24213-175

All u-bolts on this table are 3/4"-14 x Length, with a 5" diameter bend.

ALL OTHER PARTS

Due to the large number of options and variety of specifications, all other parts are itemized in the Reyco Trailer Suspension Price List (TP-295), or the latest version. If there are any more questions, refer to Reyco Customer Service 1-800-753-0050.

TYPICAL CLAMP GROUP PARTS TABLE (PARTS MOST USED)						
U-BOLT CLAMP STYLE	AXLE SIZE	TOP PLATE PART #	AXLE SET PART #	SEAT HEIGHT	BOTTOM PLATE PART #	NOTES
Conventional	5"RD	T5488	0973001	3/4"	N.N.	3/4" U-Bolts
		T7175	0973001	3/4"	N.N.	7/8" U-Bolts
		T7175	0875701	3 1/4"	N.N.	7/8" U-Bolts
	5"SQ	T5598	0798001	3/4"	T5587	3/4" U-Bolts
		T1734	0806001	3 1/4"	T5587	7/8" U-Bolts
	4"X6"	0998701	0952501	3/4"	T7560	3/4" U-Bolts
T4069		T7650	3/4"	T7560	7/8" U-Bolts	
Inverted	5"RD	1176001	0973001	3/4"	T5514	3/4" U-Bolts
		0867701	0973001	3/4"	053800	7/8" U-Bolts
		0867701	0875701	3 1/4"	053800	7/8" U-Bolts
	5"SQ	1176001	0798001	3/4"	0922901	3/4" U-Bolts
		0867701	0806001	3 1/4"	0922901	7/8" U-Bolts
	4"X6"	0867701	T7650	3/4"	0923001	7/8" U-Bolts
Inverted No Hop	5"RD	1176001	1011401	3/4"	T5481	3/4" U-Bolts
		0867701	1011401	3/4"	0848001	7/8" U-Bolts
Underslung	5"RD	NA	1011401	3/4"	T5727	3/4" U-Bolts
		NA	1011401	3/4"	T5727	7/8" U-Bolts

NOTES: Many more options and applications are available. Consult Reyco Engineering for details. Spacers are used with above parts to get the various Mounting Heights.

SKETCHES OF U-BOLT CLAMP GROUP STYLES

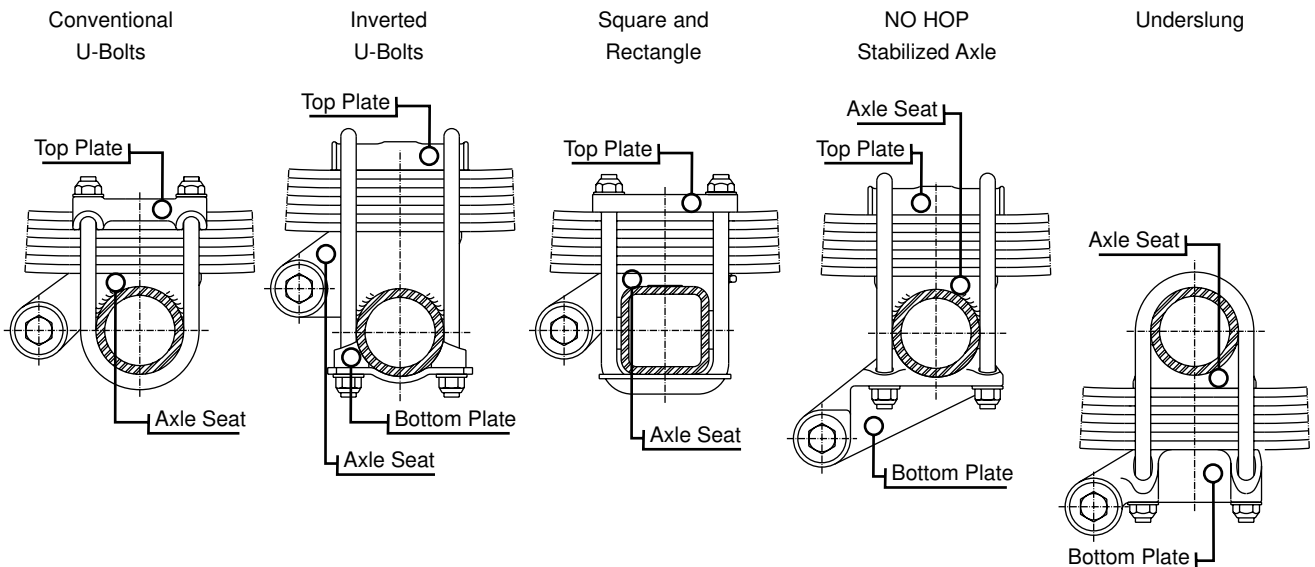

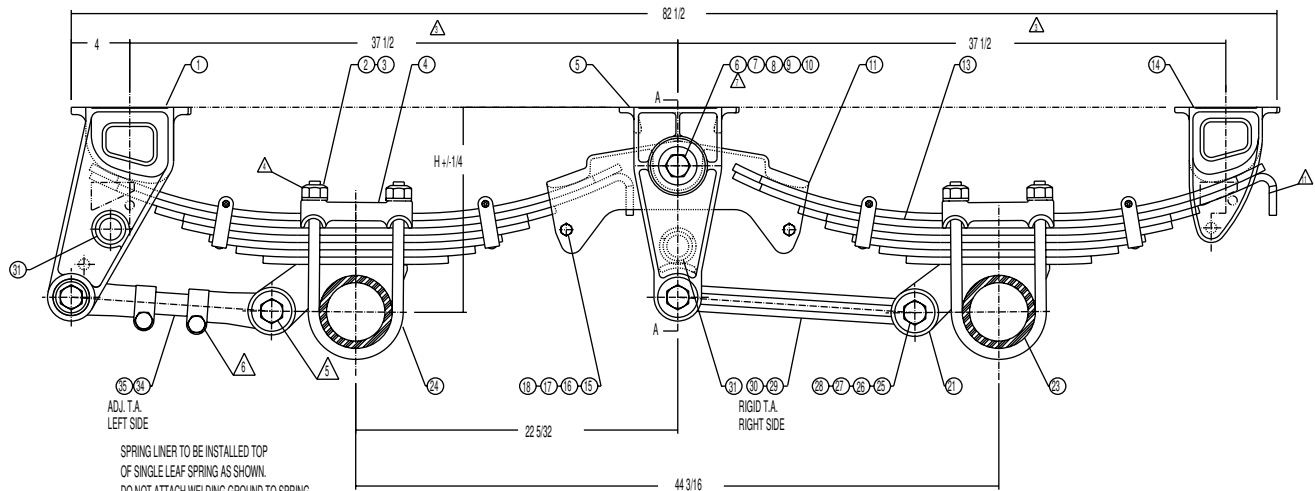

ADJ. T.A. LEFT SIDE

SPRING LINER TO BE INSTALLED TOP OF SINGLE LEAF SPRING AS SHOWN. DO NOT ATTACH WELDING GROUND TO SPRING. PROTECT SPRING FROM WELD SPATTER. SPRING SHOULD BE KEPT PAINTED.

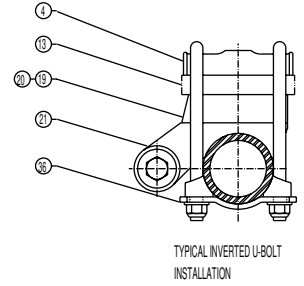

- NOTES:
1. MOUNTING HEIGHT "H" IS DIM. FROM TOP OF HANGERS TO C.L. OF AXLE WITH NO LOAD ON UNIT.
 2. MOUNT HANGER BRKTS. PARALLEL TO GROUND FOR EQUAL LOAD DISTRIBUTION.
 3. HOLD HANGER SPACING TO TOLERANCE OF $\pm 1/16"$.
 4. TIGHTEN $3/4"$ & $7/8"$ U-BOLT NUTS TO TORQUE OF 300-325 FT. LBS.
 5. TIGHTEN TORQUE ARM BOLT NUTS TO TORQUE OF 200 FT. LBS.
 6. TIGHTEN $5/8"$ TORQUE ARM TUBE CLAMP NUTS TO TORQUE OF 125-150 FT. LBS.
 7. TIGHTEN EQUALIZER BOLTS TO TORQUE 400-450 FT. LBS.
 8. SEE DWG. 63200 FOR AXLE SEAT WELD SPECS.
 9. SEE BIM 98034 FOR PARTS LIST.
 10. INSTALL SPRING WITH HOOKS TO REAR.

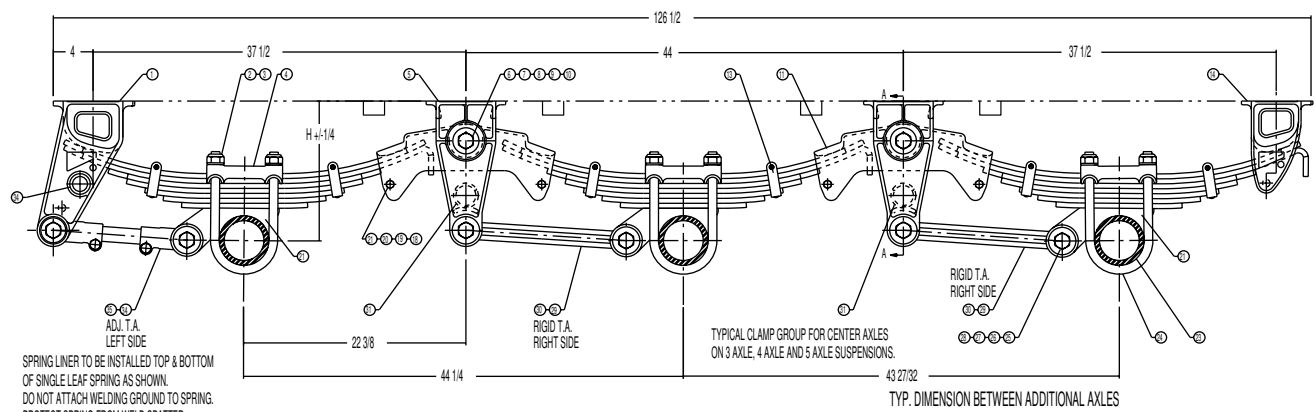
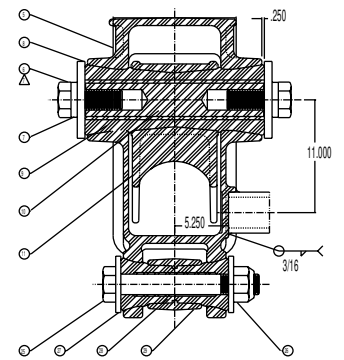

ADJ. T.A. LEFT SIDE

SPRING LINER TO BE INSTALLED TOP & BOTTOM OF SINGLE LEAF SPRING AS SHOWN. DO NOT ATTACH WELDING GROUND TO SPRING. PROTECT SPRING FROM WELD SPATTER. SPRING SHOULD BE KEPT PAINTED.

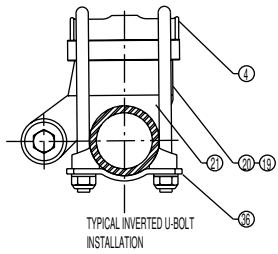

- NOTES:
1. MOUNTING HEIGHT DIM. IS FROM TOP OF HANGERS TO C.L. OF 5" RD. AXLE UNLADEN. 14" TO 18" AVAILABLE.
 2. MOUNT HANGERS PARALLEL TO GROUND FOR EQUAL LOAD DISTRIBUTION.
 3. TOLERANCE ON HANGER SPACING IS $\pm 1/16"$
 4. INSTALL SPRINGS WITH HOOK END TO REAR.
 5. SEE DRAWING 63200 FOR AXLE SEAT WELD SPECS.
 6. TIGHTEN U-BOLT NUTS TO TORQUE OF 300 FT. LBS.
 7. TIGHTEN EQUALIZER BOLTS TO TORQUE OF 450-500 FT. LBS.
 8. TIGHTEN TORQUE ARM BOLT NUTS TO TORQUE OF 140-160 FT. LBS.
 9. TIGHTEN $5/8"$ TORQUE ARM TUBE CLAMP NUTS TO TORQUE OF 125-150 FT. LBS.
 10. SEE BIM 98034 FOR PARTS LIST FOR EACH MOUNTING HEIGHT.

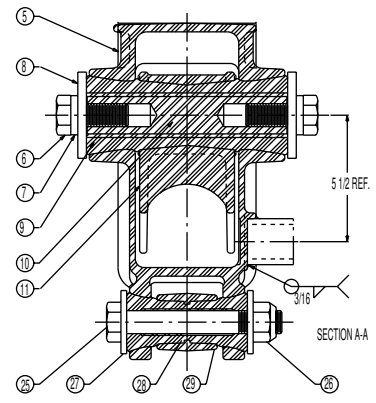

Maintenance Instructions Model 21B

Drawing - 63296-2 & 66128-2

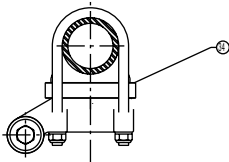
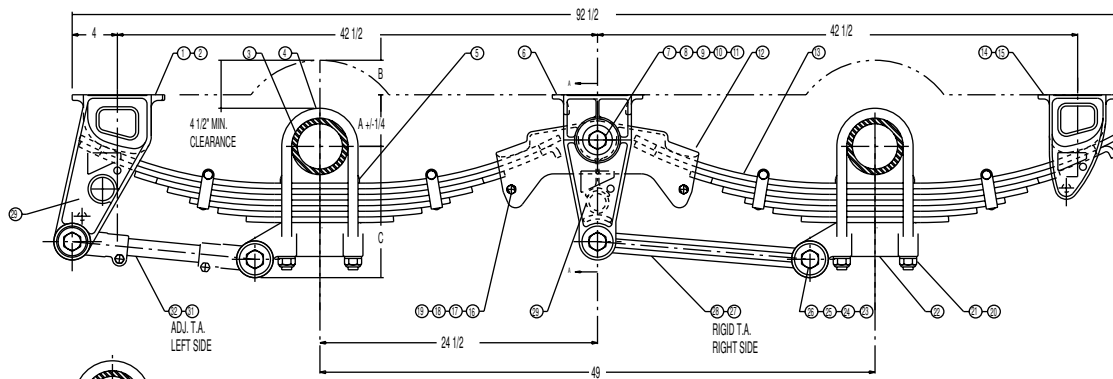

TYP. SINGLE LEAF SPRING INSTALLATION

DO NOT ATTACH WELDING GROUND TO SPRING.
PROTECT FROM WELD SPATTER.
SPRING SHOULD BE KEPT PAINTED.
SPRING LINER ITEM #35 TO BE
INSTALLED TOP OF
SINGLE LEAF SPRING.

NOTES:

1. MOUNTING HEIGHT DIMENSION "A" IS FROM TOP SURFACE OF HANGER TO C.L. AXLE WITH SPRING UNLADEN.
2. MOUNT HANGERS PARALLEL TO GROUND FOR EQUAL LOAD DISTRIBUTION.
3. HANGER SPACING SHOULD BE HELD TO TOLERANCE OF $\pm 1/16"$.
4. TIGHTEN U-BOLT NUTS TO TORQUE OF 300 FT.LBS.
5. TIGHTEN TORQUE ARM BOLT NUTS TO TORQUE OF 140-160 FT.LBS.
6. TIGHTEN 5/8" TORQUE ARM TUBE CLAMP NUTS TO TORQUE OF 125-150 FT.LBS.
7. TIGHTEN EQUALIZER BOLTS TO TORQUE OF 400-450 FT.LBS.
8. ESTIMATED WEIGHT 703.4 LBS. AS SHOWN WITH T 3086 SPRINGS, 3/4" U-BOLTS, 5" ROUND AXLES AND 3/4" SEATS.
9. SEE DRAWING 63200 FOR AXLE SEAT WELD SPECIFICATIONS.
10. SEE BILL OF MATERIAL 63296 FOR PARTS LIST.
11. INSTALL SPRINGS WITH HOOK END TO REAR.
12. DIM. "B" IS CUT-OUT REQUIRED FOR MIN. CLEARANCE WITH 5" RD. AXLE.

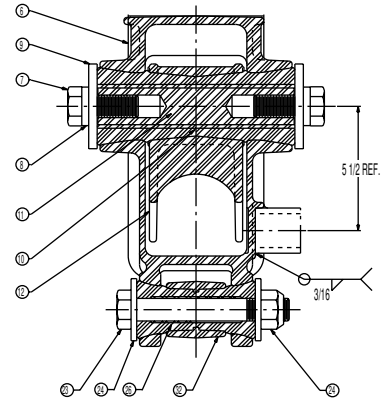

NOM. MTG. HT. "A"	SEAT HT.	SPRING CAMBER	SPRING NO.	"B" DIM.	"C" DIM.
3	3/4	LOW	T 5532	4 1/2	11 5/8
4	3/4	MEDIUM	T 3086	3 1/2	11 5/8
5	3/4	HIGH	T 5547	2 1/2	11 5/8
3	3/4	LOW	T 5592	4 1/2	12 1/8
4	3/4	MEDIUM	T 3964	3 1/2	12 1/8
5	3/4	HIGH	T 5597	2 1/2	12 1/8
5	3/4	MEDIUM	08376 01	2 1/2	10 5/8
4	3/4	MEDIUM	T 7452	3 1/2	12 5/8
4	3/4	MEDIUM	T 5555	3 1/2	9 5/8
6	3/4	HIGH	15636 01	1 1/2	9 7/8

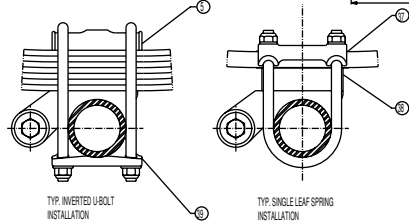
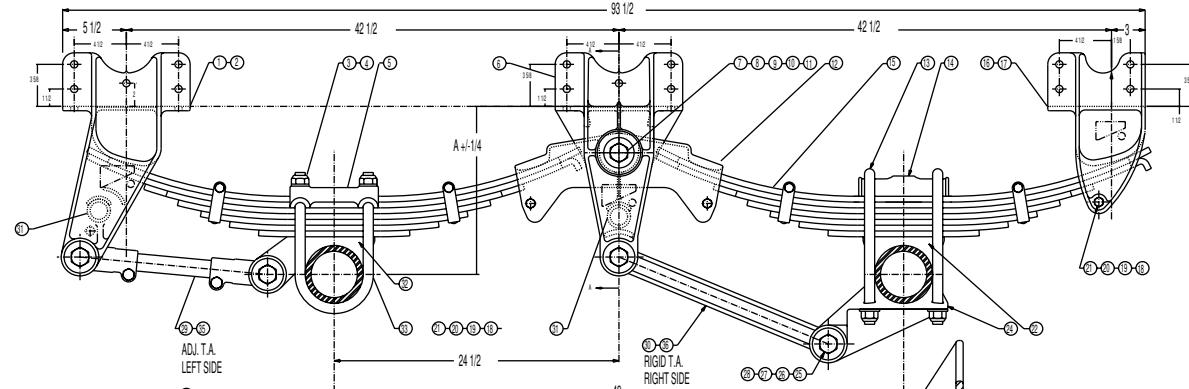

TYP. INVERTED U-BOLT INSTALLATION

TYP. SINGLE LEAF SPRING INSTALLATION

DO NOT ATTACH WELDING GROUND TO SPRING.
PROTECT FROM WELD SPATTER.
SPRING SHOULD BE KEPT PAINTED.
SPRING LINER ITEM #35 TO BE
INSTALLED TOP OF
SINGLE LEAF SPRING.

NOTES:

1. MOUNTING HEIGHT DIMENSION "A" IS FROM TOP SURFACE OF HANGER TO - AXLE WITH SPRING UNLADEN.
2. MOUNT HANGERS PARALLEL TO GROUND FOR EQUAL LOAD DISTRIBUTION.
3. HANGER SPACING SHOULD BE HELD TO TOLERANCE OF $\pm 1/16"$.
4. TIGHTEN U-BOLT NUTS TO TORQUE OF 300 FT.LBS.
5. TIGHTEN TORQUE ARM BOLT NUTS TO TORQUE OF 140-160 FT.LBS.
6. TIGHTEN 5/8" TORQUE ARM TUBE CLAMP NUTS TO TORQUE OF 125-150 FT.LBS.
7. TIGHTEN EQUALIZER BOLTS TO TORQUE OF 400-450 FT.LBS.
8. ESTIMATED WEIGHT 757 LBS. AS SHOWN WITH T 3086 SPRINGS, 7/8" U-BOLTS, 5" ROUND AXLES AND 3/4" SEATS.
9. SEE DRAWING 63200 FOR AXLE SEAT WELD SPECIFICATIONS.
10. SEE BILL OF MATERIAL 63159 FOR PARTS LIST.
11. INSTALL SPRINGS WITH HOOK END TO REAR.

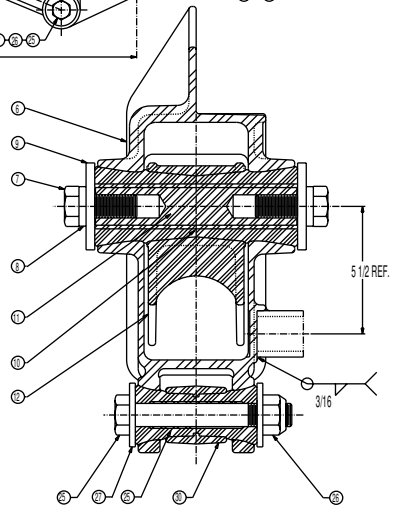

NOM. MTG. HT. "A"	SEAT HT.	SPRING CAMBER
13	3/4	LOW
14	3/4	MEDIUM
15	3/4	HIGH
16	3 1/4	LOW
17	3 1/4	MEDIUM
18	3 1/4	HIGH
14	2 3/4	SINGLE LEAF SPG.

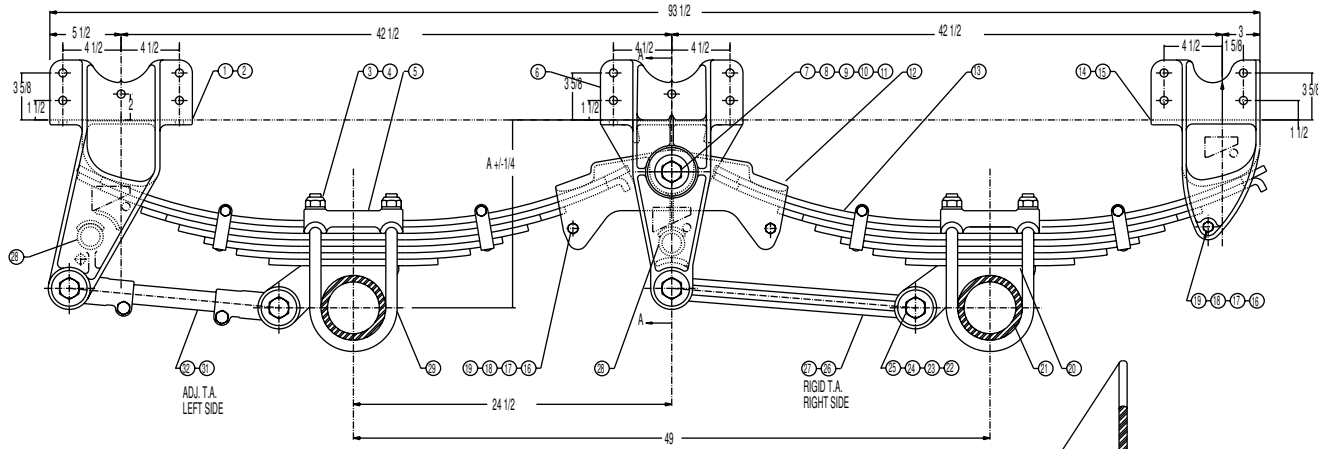

NOM. MTG. HT."A"	SEAT HT.	SPRING CAMBER
13	3/4	LOW
14	3/4	MEDIUM
15	3/4	HIGH
16	3 1/4	LOW
17	3 1/4	MEDIUM
18	3 1/4	HIGH
14	2 3/4	SINGLE LEAF SPG.

NOTES:

1. MOUNTING HEIGHT DIMENSION "A" IS FROM TOP SURFACE OF HANGER TO - AXLE WITH SPRING UNLADEN.
2. MOUNT HANGERS PARALLEL TO GROUND FOR EQUAL LOAD DISTRIBUTION.
3. HANGER SPACING SHOULD BE HELD TO TOLERANCE OF $\pm 1/16"$.
4. TIGHTEN U-BOLT NUTS TO TORQUE OF 300 FT.LBS.
5. TIGHTEN TORQUE ARM BOLT NUTS TO TORQUE OF 140-160 FT.LBS.
6. TIGHTEN 5/8" TORQUE ARM TUBE CLAMP NUTS TO TORQUE OF 125-15
7. TIGHTEN EQUALIZER BOLTS TO TORQUE OF 400-450 FT.LBS.
8. ESTIMATED WEIGHT 730 LBS. AS SHOWN WITH T 3086 SPRINGS, 7/8" U-BOLTS, 5" ROUND AXLES AND 3/4" SEATS.
9. SEE DRAWING 63200 FOR AXLE SEAT WELD SPECIFICATIONS.
10. SEE BILL OF MATERIAL 63159 FOR PARTS LIST.
11. INSTALL SPRINGS WITH HOOK END TO REAR.

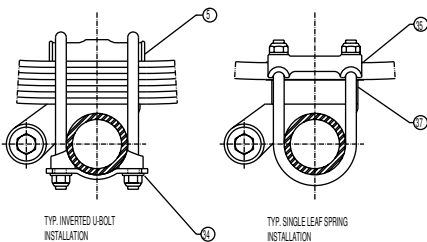
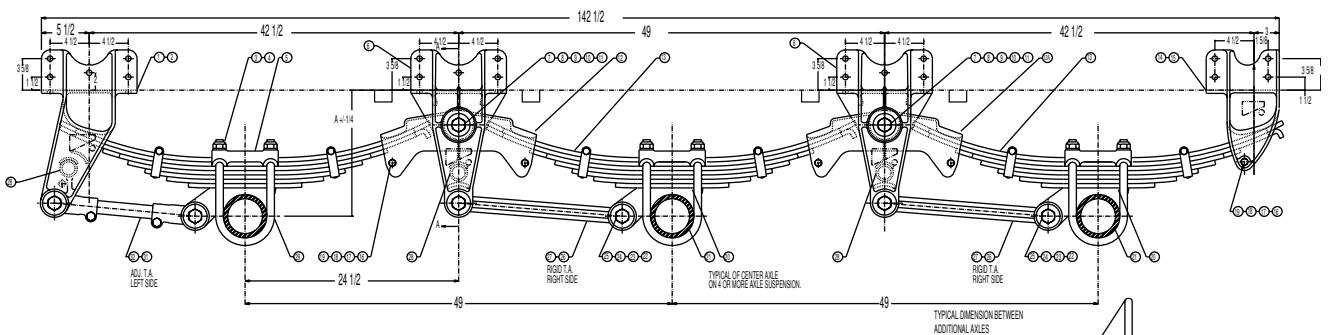
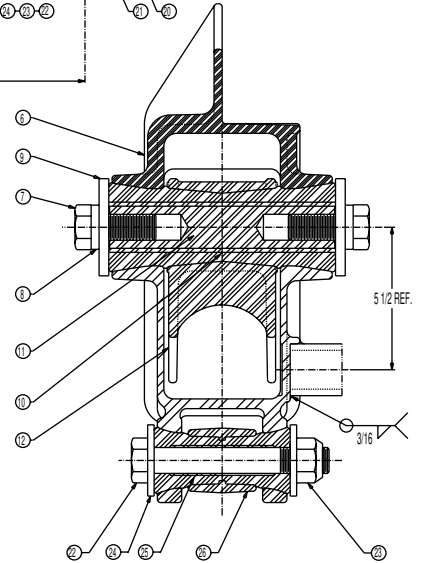

DO NOT ATTACH WELDING GROUND TO SPRING.
 PROTECT FROM WELD SPATTER.
 SPRING SHOULD BE KEPT PAINTED.
 SPRING LINER ITEM #55 TO BE
 INSTALLED TOP OF
 SINGLE LEAF SPRING.

NOTES:

1. MOUNTING HEIGHT DIMENSION "A" IS FROM TOP SURFACE OF HANGER TO - AXLE WITH SPRING UNLADEN.
2. MOUNT HANGERS PARALLEL TO GROUND FOR EQUAL LOAD DISTRIBUTION.
3. HANGER SPACING SHOULD BE HELD TO TOLERANCE OF $\pm 1/16"$.
4. TIGHTEN U-BOLT NUTS TO TORQUE OF 300 FT.LBS.
5. TIGHTEN TORQUE ARM BOLT NUTS TO TORQUE OF 140-160 FT.LBS.
6. TIGHTEN 5/8" TORQUE ARM TUBE CLAMP NUTS TO TORQUE OF 125-150 FT.LBS.
7. TIGHTEN EQUALIZER BOLTS TO TORQUE OF 400-450 FT.LBS.
8. ESTIMATED WEIGHT 1056 LBS. AS SHOWN WITH T 3086 SPRINGS, 7/8" U-BOLTS, 5" ROUND AXLES AND 3/4" SEATS.
9. SEE DRAWING 63200 FOR AXLE SEAT WELD SPECIFICATIONS.
10. SEE BILL OF MATERIAL 63159 FOR PARTS LIST.
11. INSTALL SPRINGS WITH HOOK END TO REAR.

NOM. MTG. HT."A"	SEAT HT.	SPRING CAMBER
13	3/4	LOW
14	3/4	MEDIUM
15	3/4	HIGH
16	3 1/4	LOW
17	3 1/4	MEDIUM
18	3 1/4	HIGH
14	2 3/4	SINGLE LEAF SPG.

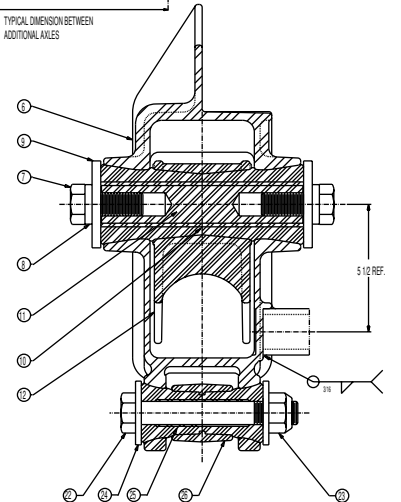

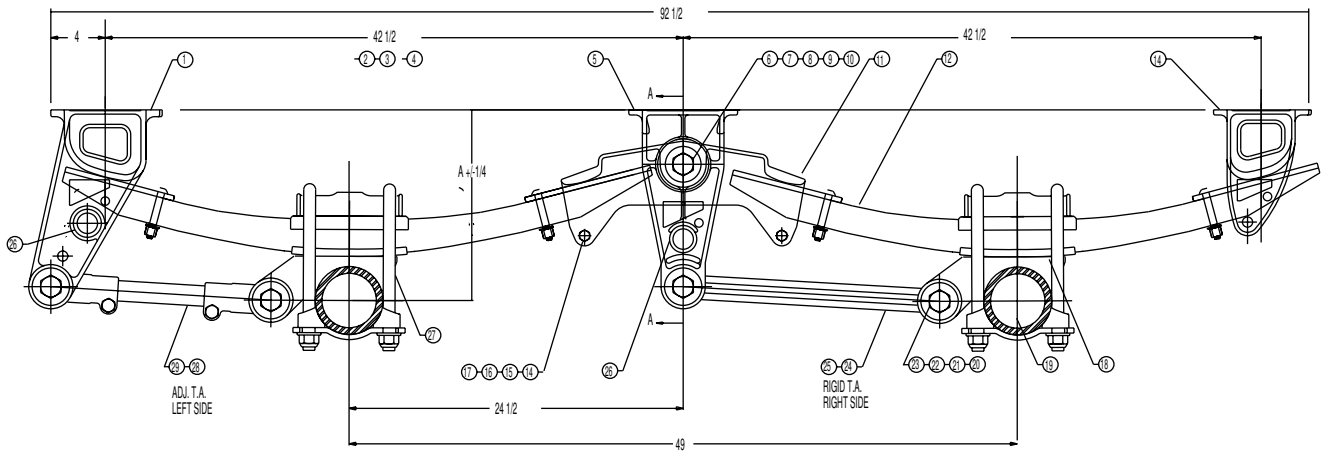

- NOTES:
1. MOUNTING HEIGHT DIMENSION "A" IS FROM TOP SURFACE OF HANGER TO C.L. AXLE WITH SPRING UNLOADED.
 2. MOUNT HANGERS PARALLEL TO GROUND FOR EQUAL LOAD DISTRIBUTION.
 3. HANGER SPACING SHOULD BE HELD TO TOLERANCE OF +/-1/16".
 4. TIGHTEN U-BOLT NUTS TO TORQUE OF 300 FT.LBS.
 5. TIGHTEN TORQUE ARM BOLT NUTS TO TORQUE OF 140-160 FT.LBS.
 6. TIGHTEN 5/8" TORQUE ARM TUBE CLAMP NUTS TO TORQUE OF 125-150 FT.LBS.
 7. TIGHTEN EQUALIZER BOLTS TO TORQUE OF 450-500 FT.LBS.
 8. SEE DRAWING 63200 FOR AXLE SEAT WELD SPECIFICATIONS.
 9. SEE BILL OF MATERIAL 98033 FOR PARTS LIST.
 10. INSTALL SPRINGS WITH HOOK END TO REAR.

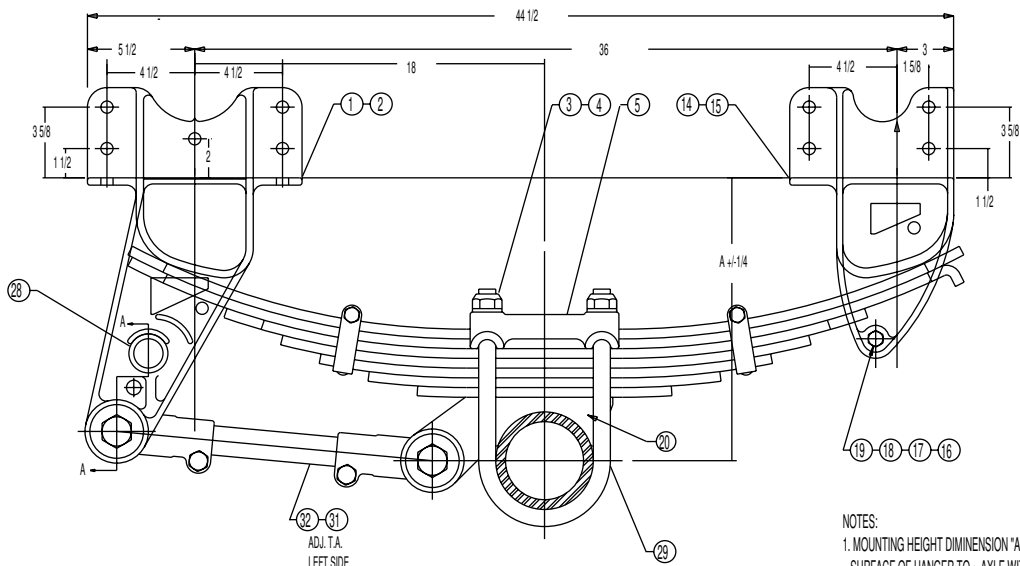
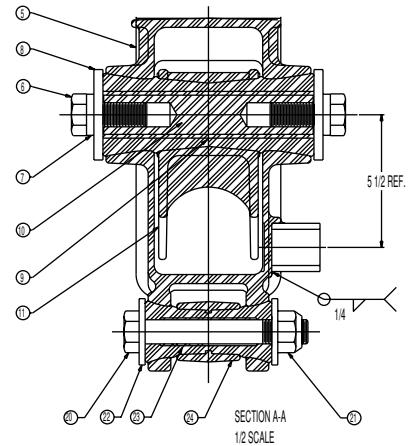

- NOTES:
1. MOUNTING HEIGHT DIMENSION "A" IS FROM TOP SURFACE OF HANGER TO - AXLE WITH SPRING UNLOADED.
 2. MOUNT HANGERS PARALLEL TO GROUND FOR EQUAL LOAD DISTRIBUTION.
 3. HANGER SPACING SHOULD BE HELD TO TOLERANCE OF +/-1/16".
 4. TIGHTEN U-BOLT NUTS TO TORQUE OF 300 FT.LBS.
 5. TIGHTEN TORQUE ARM BOLT NUTS TO TORQUE OF 140-160 FT.LBS.
 6. TIGHTEN 5/8" TORQUE ARM TUBE CLAMP NUTS TO TORQUE OF 125-150 FT.LBS.
 7. ESTIMATED WEIGHT 345 LBS. AS SHOWN WITH T 3086 SPRINGS, 7/8" U-BOLTS, 5" ROUND AXLES AND 3/4" SEATS.
 8. SEE DRAWING 63200 FOR AXLE SEAT WELD SPECIFICATIONS.
 9. SEE BILL OF MATERIAL 63159 FOR PARTS LIST.
 10. INSTALL SPRINGS WITH HOOK END TO REAR.

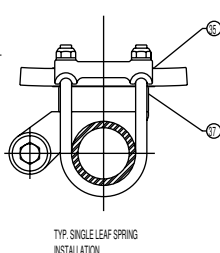
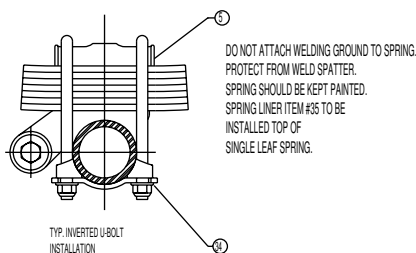

NOM. MTG. HT. "A"	SEAT HT.	SPRING CAMBER
13	3/4	LOW
14	3/4	MEDIUM
15	3/4	HIGH
16	3 1/4	LOW
17	3 1/4	MEDIUM
18	3 1/4	HIGH
14	2 3/4	SINGLE LEAF SPG.

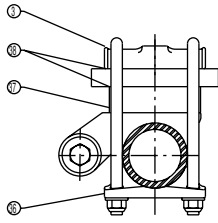
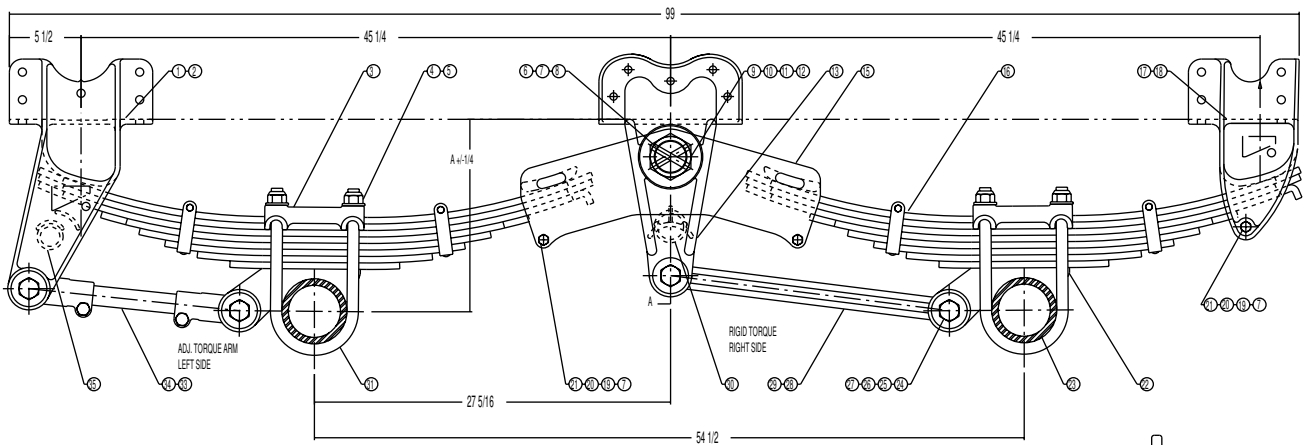

TYP. INSTALLATION
SINGLE LEAF SPRING
AND INVERTED U-BOLTS

INSTALL SPRING LINER TOP AND BOTTOM
OF SINGLE LEAF SPRING.

DO NOT ATTACH WELDING GROUND
TO SPRING. PROTECT FROM WELD SPATTER.
SPRING SHOULD BE KEPT PAINTED.

NOMINAL MOUNTING HT. "A" DIM.	SEAT HT.	SPRING CAMBER
13	3/4	LOW
14	3/4	MED.
15	3/4	HIGH
14	2 3/4	MED. SING. LEAF
16	3 1/4	LOW
17	3 1/4	MED.
18	3 1/4	HIGH

NOTES:

1. MOUNTING HEIGHT "A" IS FROM BOTTOM OF FRAME TO - OF 5" RD. AXLE WITH NO LOAD ON TANDEM.
2. MOUNT HANGER BRACKETS PARALLEL TO GROUND FOR EQUAL LOAD DISTRIBUTION.
3. SPACING OF HANGER BRACKETS SHOULD BE HELD TO TOLERANCE OF +/-1/16".
4. TIGHTEN U-BOLT NUTS TO TORQUE OF 300FT.LBS.
5. TIGHTEN TORQUE ARM BOLT NUTS TO TORQUE OF 140-160 FT.LBS.
6. TIGHTEN 5/8" TORQUE TUBE CLAMP NUTS TO TORQUE OF 125-150FT.LBS.
7. TIGHTEN EQUALIZER SHAFT NUTS TO TORQUE OF 300FT.LBS. MAX. MAINTAIN 1/32" CLEARANCE BETWEEN WASHER AND CASTING.
8. SEE DRAWING 63200 FOR AXLE SEAT WELDING SPECS.
9. ESTIMATED WEIGHT 820 LBS. AS SHOWN WITH T 3564 SPRINGS, 3/4" HIGH SEAT, AND 5" RD. AXLE.
10. INSTALL SPRINGS WITH HOOKS TO REAR.

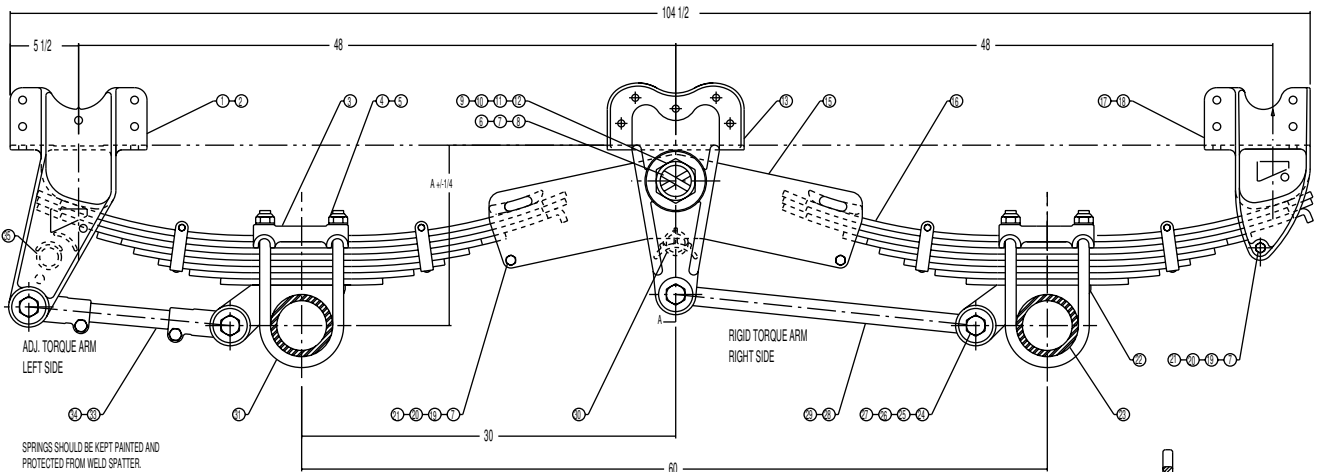
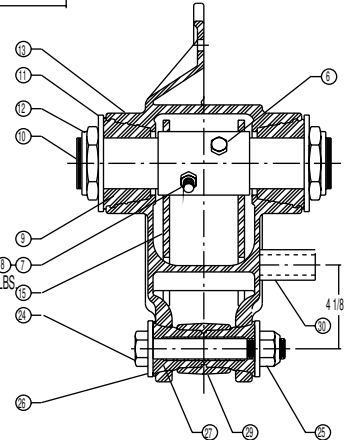

SPRINGS SHOULD BE KEPT PAINTED AND
PROTECTED FROM WELD SPATTER.
DO NOT ATTACH WELDING GROUND TO
SPRINGS.

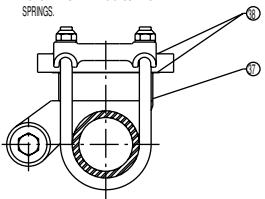

TYP. INSTALLATION
SINGLE LEAF SPRING

SPRING LINERS MUST BE INSTALLED TOP AND
BOTTOM OF SINGLE LEAF SPRINGS.

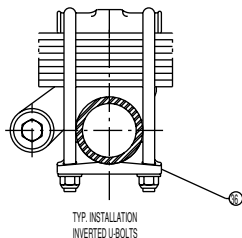

TYP. INSTALLATION
INVERTED U-BOLTS

NOM. MTG. HT. "A"	SEAT HT.	SPRING CAMBER
13	3/4	LOW
14	3/4	MED.
14	2 3/4	MED. (S.L.)

NOTES:

1. "A" DIM. IS FROM BOTTOM OF FRAME TO - OF 5" DIA. AXLE WITH NO LOAD ON TANDEM.
2. MOUNT HANGER BRACKETS PARALLEL TO GROUND FOR EQUAL LOAD DISTRIBUTION.
3. HANGER BRACKET SPACING SHOULD BE HELD WITHIN TOLERANCE OF +/-1/16".
4. TIGHTEN U-BOLT NUTS TO TORQUE OF 300 FT.LBS.
5. TIGHTEN TORQUE ARM BOLT NUTS TO TORQUE OF 140-160 FT.LBS.
6. TIGHTEN 5/8" TORQUE ARM TUBE CLAMP NUTS TO TORQUE OF 125-150 FT.LBS.
7. SEE DRAWING 63200 FOR AXLE SEAT WELD SPECIFICATIONS
8. ESTIMATED WEIGHT 828 LBS. WITH T 3564 SPRINGS, 3/4" U-BOLTS AND 5" ROUND AXLES.
9. TIGHTEN EQUALIZER SHAFT NUTS TO TORQUE OF 300 FT.LBS. MAX. TORQUE
10. INSTALL SPRINGS WITH HOOKS TO REAR.

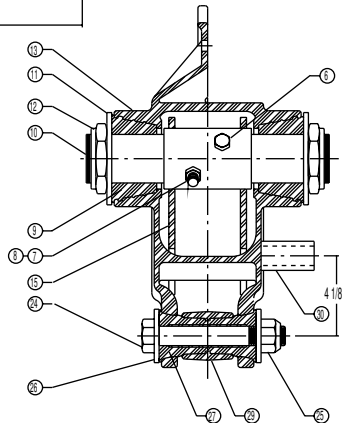

Maintenance Instructions Model 21B

Drawing - 87-188-2 & 83006

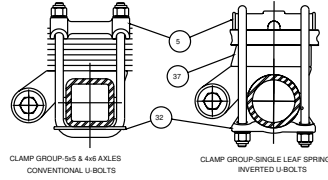
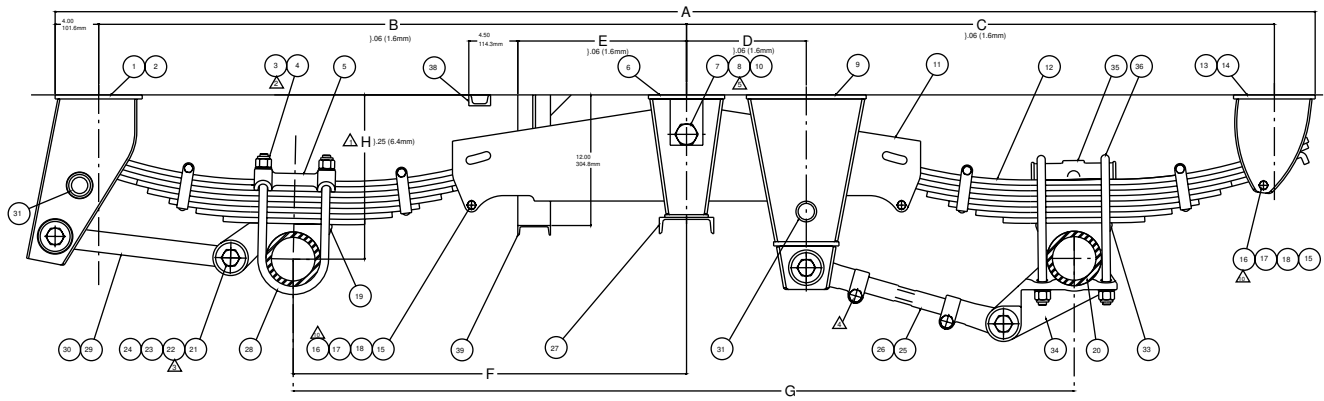

	2769mm	3880mm	1842mm	1842mm	749mm	864mm	1384mm	2769mm
	109	152.75	72.50	72.50	29.50	34.00	54.50	109.00
	2464mm	3575mm	1689mm	1689mm	597mm	711mm	1232mm	2464mm
	97	140.75	66.50	66.50	23.50	28.00	48.50	97.00
	1829mm	2940mm	1372mm	1372mm	279mm	394mm	914mm	1829mm
	72	115.75	54.00	54.00	11.00	15.50	36.00	72.00
AXLE	A	B	C	D	E	F	NOM.	G
SPACING	DIMENSION							

NOTES:

1. SEE BILL OF MATERIAL FOR MOUNTING HEIGHT "H".
2. TIGHTEN U-BOLT NUTS TO 300-325 FT-LB (410-440 Nm) TORQUE.
3. TIGHTEN TORQUE ARM BOLT NUTS TO 160-200 FT-LB (215-270 Nm).
4. TIGHTEN 5/8" TORQUE ARM CLAMP NUTS TO 125-150 FT-LB (170-200 Nm).
5. TIGHTEN EQUALIZER SHAFT NUT TO 575-625 FT-LB (780-850 Nm).
6. INSTALL REVCO SPRINGS WITH HOOKS TO REAR.
7. INSTALL SPRING LINER ON TOP & BOTTOM OF SINGLE-LEAF SPRING, ON TOP ONLY OF THREE-LEAF SPRING.
8. INSTALL RIGID TORQUE ARMS ON CURB SIDE OF SUSPENSION.
9. INSTALL HANGERS PARALLEL TO GROUND FOR EQUAL WEIGHT DISTRIBUTION.
10. TIGHTEN SPRING RETAINER BOLT NUTS TO 60-80 FT-LB (80-110 Nm).

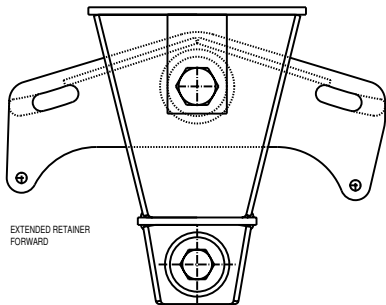
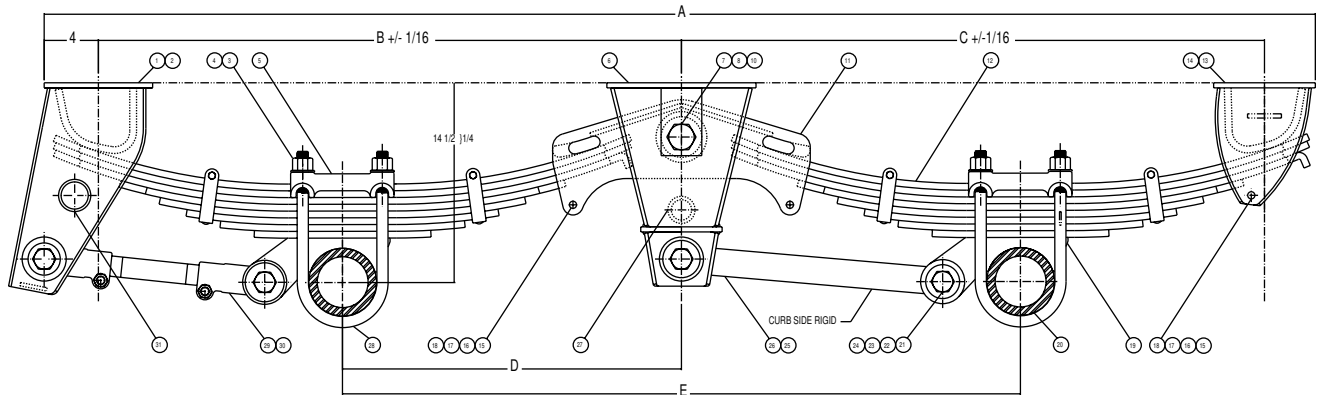

EQUALIZER & BRACKET ASSEMBLY 44" AXLE SPACING

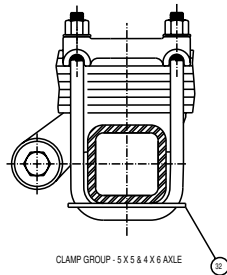

CLAMP GROUP - 5 X 5 & 4 X 6 AXLE

(1118)	(2102)	(953)	(953)	(567)	(1122)
44	82 3/4	37 1/2	37 1/2	22 5/16	44 3/16
(1651)	(2769)	(1286)	(1286)	(829)	(1664)
65	109	50 5/8	50 5/8	32 5/8	65 1/2
(1600)	(2724)	(1264)	(1264)	(810)	(1616)
63	107 1/4	49 3/4	49 3/4	31 7/8	63 5/8
(1524)	(2635)	(1219)	(1219)	(762)	(1524)
60	103 3/4	48	48	30	60
(1372)	(2502)	(1149)	(1149)	(694)	(1384)
54	98 1/2	45 1/4	45 1/4	27 5/16	54 1/2
(1270)	(2381)	(1092)	(1092)	(635)	(1270)
50	93 3/4	43	43	*25	*50
AXLE	A	B	C	D	E
SPACING	DIMENSION				

NOTES:

1. MOUNTING HEIGHT DIMENSION IS FOR MEDIUM ARCH SPRINGS. 5" ROUND AXLE 3/4" HIGH SEAT, & UNLADEN TANDEM.
2. MOUNT HANGERS PARALLEL TO GROUND FOR EQUAL WEIGHT DISTRIBUTION.
3. TIGHTEN U-BOLT NUTS TO 300 LB.-FT. (410 N-m) TORQUE.
4. TIGHTEN TORQUE ARM BOLT NUTS TO 140-160 LB.-FT.
5. TIGHTEN TORQUE ARM CLAMP NUTS TO 80 LB.-FT. (110 N-m) (FOR FABRICATED TORQUE ARM ENDS)
6. TIGHTEN EQUALIZER SHAFT NUT TO 575-625 LB.-FT. (780-850 N-m)
7. INSTALL SPRINGS WITH HOOKS TO REAR.
8. DIMENSIONS ARE IN INCHES & MILLIMETERS.
9. FOR 50" AX. SPCG. WITH T-7452 SPRING USING T-7633 RIGID FRONT TORQUE ARM: DIM. D IS 25 1/2; DIM. E IS 50 1/2.
10. TIGHTEN NUTS ON CAST ADJUSTABLE TORQUE ARM ENDS TO 125-150 LB.-FT.

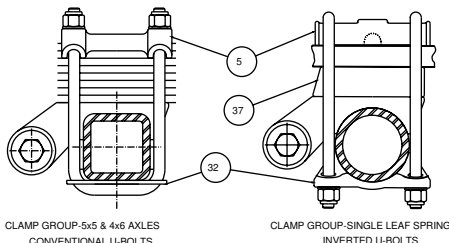
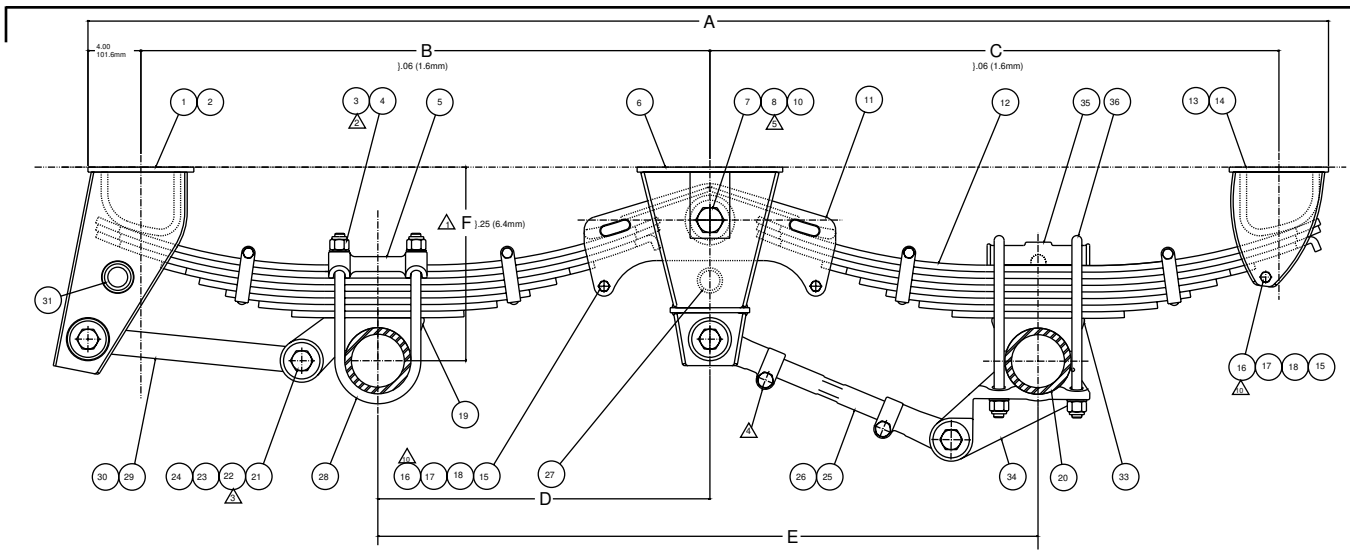
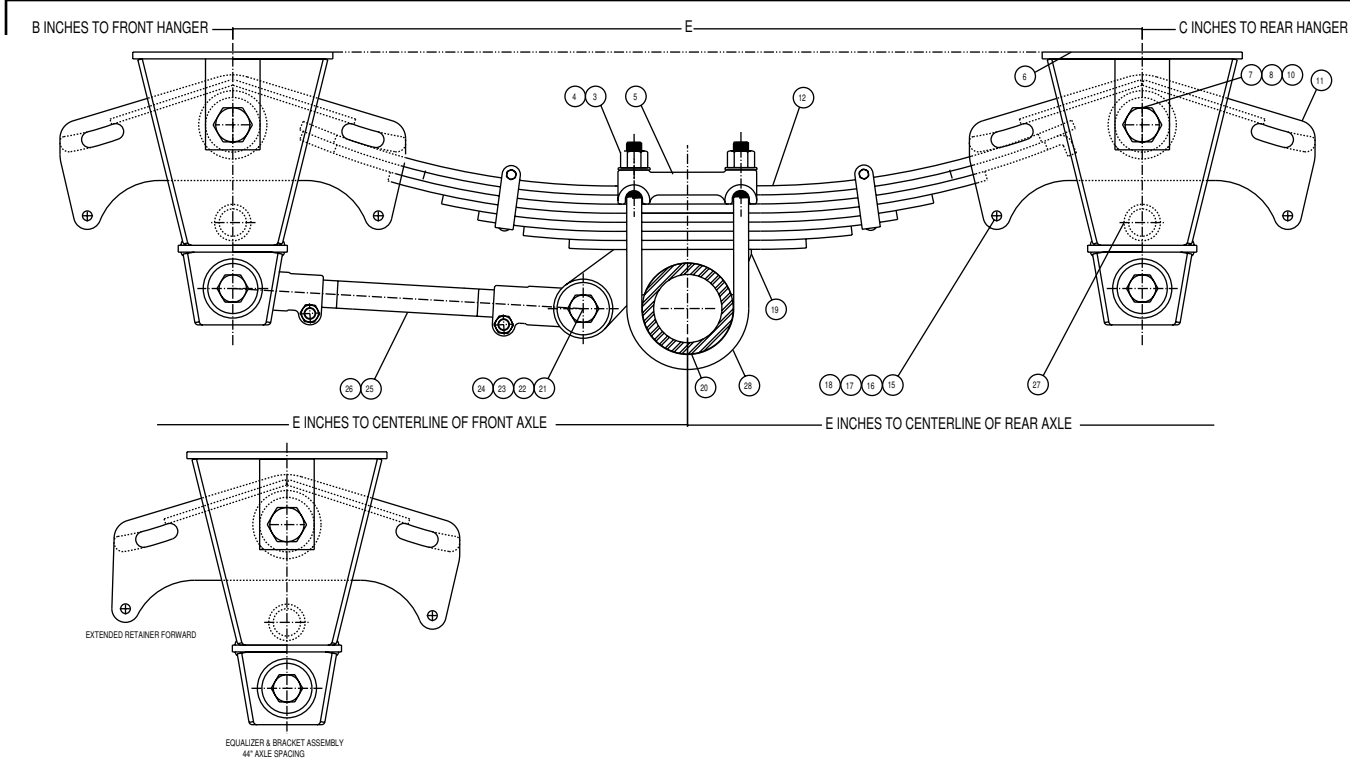

- NOTES:
1. SEE BILL OF MATERIAL FOR MOUNTING HEIGHT "F".
 2. TIGHTEN U-BOLT NUTS TO 300-325 FT-LB (410-440 Nm) TORQUE.
 3. TIGHTEN TORQUE ARM BOLT NUTS TO 160-200 FT-LB (270-340 Nm).
 4. TIGHTEN 5/8" TORQUE ARM CLAMP NUTS TO 125-150 FT-LB (170-200 Nm).
 5. TIGHTEN EQUALIZER SHAFT NUT TO 575-625 FT-LB (780-850 Nm).
 6. INSTALL REYCO SPRINGS WITH HOOKS TO REAR.
 7. INSTALL SPRING LINER ON TOP & BOTTOM OF SINGLE-LEAF SPRING, ON TOP ONLY OF THREE-LEAF SPRING.
 8. INSTALL RIGID TORQUE ARMS ON CURB SIDE OF SUSPENSION.
 9. INSTALL HANGERS PARALLEL TO GROUND FOR EQUAL WEIGHT DISTRIBUTION.
 10. TIGHTEN SPRING RETAINER BOLT NUTS TO 60-80 FT-LB (80-110 Nm).

	65	109.00	50.63	50.63	32.63	65.50
	1651mm	2769mm	1286mm	1286mm	829mm	1664mm
	63	107.25	49.75	49.75	31.88	63.63
	1600mm	2724mm	1264mm	1264mm	810mm	1616mm
(A)	60	103.75	48.00	48.00	30.00	60.00
	1524mm	2635mm	1219mm	1219mm	762mm	1524mm
	54	98.50	45.25	45.25	27.31	54.50
	1372mm	2502mm	1149mm	1149mm	694mm	1384mm
	50	93.75	43.00	43.00	25.00	50.00
	1270mm	2381mm	1092mm	1092mm	635MM	1270mm
AXLE A		B	C	D	NOM. E	NOM.
SPACING		DIMENSION				

Maintenance Instructions Model 21B

Drawing - 73129-2 & 74021

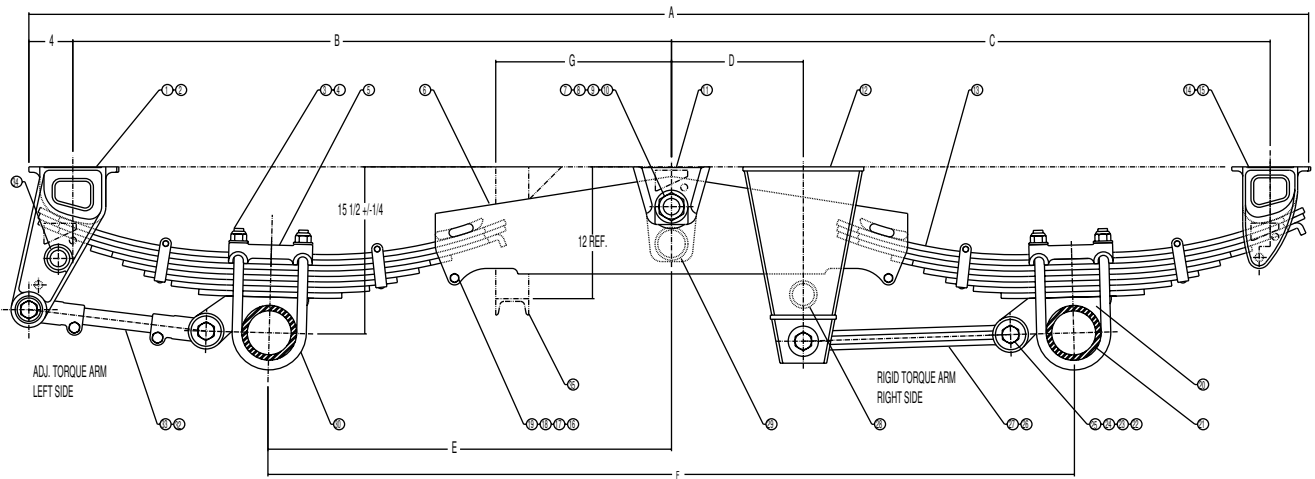

AXLE SPACING	DIMENSION TABLE						
	A	B	C	D	E	F	G
6'-1"	116 1/2	54 1/2	54 1/2	12	36 1/2	73	16
	2959mm	1384mm	1384mm	305mm	927mm	1854mm	406mm
8'-1"	140 1/2	66 1/2	66 1/2	24	48 1/2	97	28
	3569mm	1689mm	1689mm	610mm	1232mm	2464mm	711mm
9'-1"	152 1/2	72 1/2	72 1/2	30	54 1/2	109	34
	3874mm	1842mm	1842mm	762mm	1384mm	2769mm	864mm
10'-1"	164 1/2	78 1/2	78 1/2	36	60 1/2	121	40
	4178mm	1994mm	1994mm	914mm	1537mm	3073mm	1016mm
6'-0"	115 1/2	54	54	11 1/2	36	72	15 1/2
	2934mm	1372mm	1372mm	292mm	914mm	1829mm	394mm

- NOTES:
1. MTG. HT. DIMENSION SHOWN IS WITH MED. ARCH SPRINGS, 5" ROUND AXLES AND NO LOAD ON TANDEM.
 2. HANGER SPACING SHOULD BE HELD TO TOLERANCE OF +/-1/16".
 3. MOUNT HANGERS PARALLEL TO GROUND FOR EQUAL LOAD DISTRIBUTION.
 4. TIGHTEN TORQUE ARM BOLT NUTS TO 140-160 FT.LBS.
 5. TIGHTEN 5/8" TORQUE ARM TUBE CLAMP NUTS TO 125-150 FT.LBS.
 6. TIGHTEN U-BOLT NUTS TO 300 FT.LBS.
 7. TIGHTEN EQUALIZER SHAFT NUTS TO 200 FT.LBS.
 8. REINFORCEMENT BRIDGING BETWEEN HANGER BRACE PIPES AND FRAME CROSSMEMBERS IS RECOMMENDED.
 9. DIMENSIONS ARE SHOWN IN INCHES AND MILLIMETERS.
 10. MAKE EQUALIZER BRACE (ITEM 35) FROM 3" CHANNEL.
 11. SPRINGS SHOULD BE INSTALLED WITH HOOKS TO REAR.

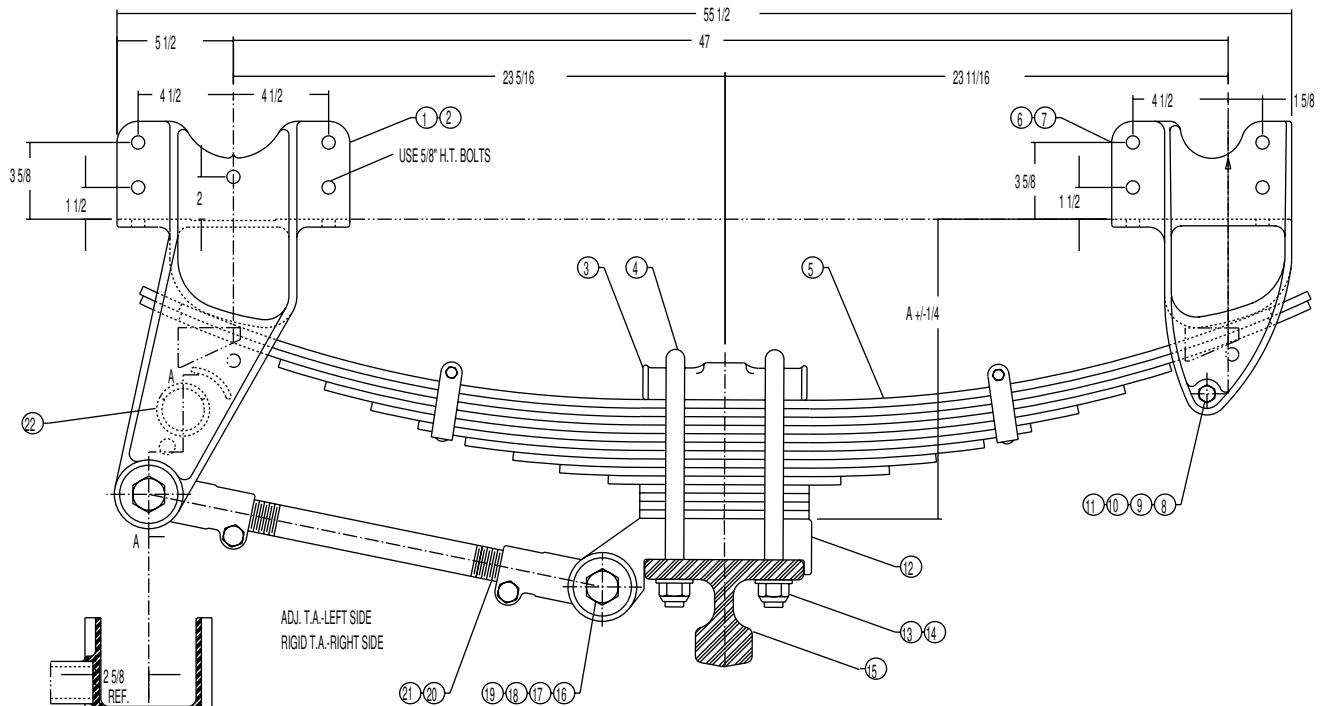

20000	18677 01	14 1/2	516
14600	18676 02	13	444
14600	18676 01	14	462
12000 TO 13200	18675 02	12 1/2	406
12000 TO 13200	18675 01	14	430
AXLE CAPACITY	SPRING NO.	A DIM.	ASSY. WT.

- NOTES:
1. MOUNTING HEIGHT (A DIM.) IS UNLADEN.
 2. INSTALL HANGERS TO TOLERANCE OF +/-1/16".
 3. TIGHTEN U-BOLT NUTS TO TORQUE OF 300 FT.LBS.
 4. TIGHTEN TORQUE ARM BOLT NUTS TO 140-160 FT.LBS.
 5. TIGHTEN 5/8" TORQUE ARM TUBE CLAMP NUTS TO TORQUE OF 125-150 FT.LBS.

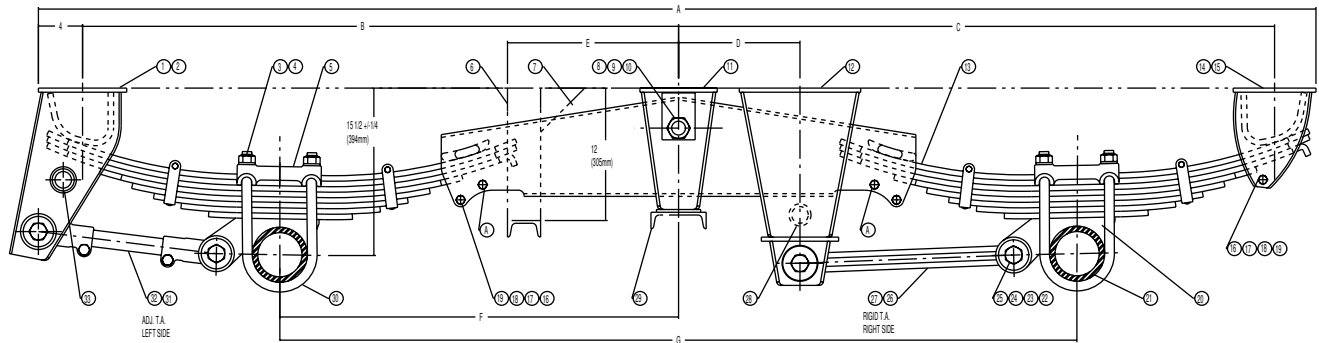
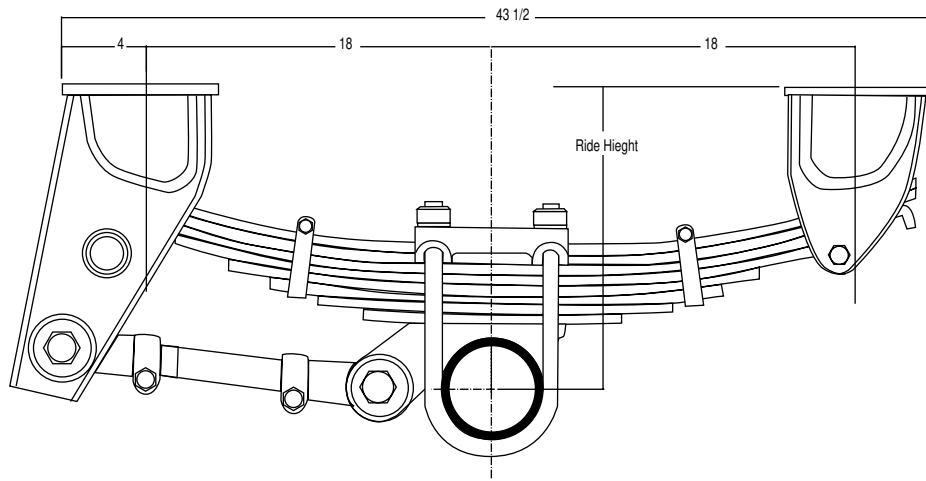

109" (2769mm)	152 3/4" (3880mm)	72 1/2" (1842mm)	72 1/2" (1842mm)	29 1/2" (749mm)	34" (864mm)	54 1/2" (1384mm)	109" (2769mm)
97" (2466mm)	140 3/4" (3575mm)	66 1/2" (1689mm)	66 1/2" (1689mm)	23 1/2" (597mm)	28" (711mm)	48 1/2" (1232mm)	97" (2464mm)
73" (1854mm)	116 3/4" (2966mm)	54 1/2" (1384mm)	54 1/2" (1384mm)	11 1/2" (292mm)	16" (406mm)	36 1/2" (927mm)	73" (1854mm)
72" (1829mm)	115 3/4" (2940mm)	54" (1372mm)	54" (1372mm)	11" (279mm)	15 1/2" (394mm)	36" (914mm)	72" (1829mm)
AXLE SPACING	A	B	C	D	E	F	G

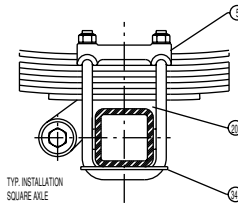

TYP. INSTALLATION SQUARE AXLE

NOTES:

1. MOUNTING HEIGHT, 15 1/2" DIM. IS WITH 5" RD. AXLE, MEDIUM ARCH SPRINGS AND NO LOAD ON TANDEM.
2. MOUNT HANGERS PARALLEL TO GROUND FOR EQUAL LOAD DISTRIBUTION. HOLD SPACING TO TOLERANCE OF +/-1/16".
3. TIGHTEN TORQUE ARM BOLT NUTS TO TORQUE OF 140-160 FT.LBS.
4. TIGHTEN U-BOLT NUTS TO TORQUE 300-325 FT.LBS.
5. TIGHTEN TORQUE ARM TUBE CLAMP NUTS TO TORQUE OF 125-150 FT.LBS.
6. TIGHTEN EQUALIZER SHAFT NUT TO TORQUE OF 575-625 FT.LBS.
7. REINFORCEMENT BRIDGING BETWEEN HANGER CROSS-BRACES AND FRAME IS RECOMMENDED.
8. USE THIS SET OF EQUALIZER BOLT HOLES (A) FOR 72" AXLE SPACING ONLY.
9. MAKE EQUALIZER BRACE (ITEM 6) FROM 3" CHANNEL. MAKE CENTER HANGER BRACE (ITEM 23) FROM 5" CHANNEL.
10. DIMENSIONS SHOWN IN INCHES AND MILLIMETERS.

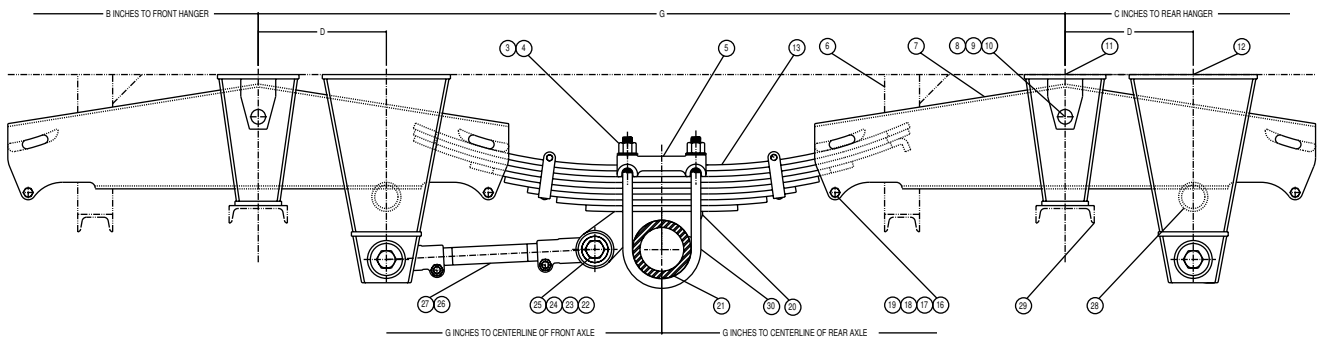

Maintenance Instructions Model 21B

Tuthill Transport Technologies (TTT) (The Company) warrants ReycoGranning suspension products manufactured by it to be free from defect in material and workmanship which occur under normal use and service subject to the following conditions and limitations.

Trailer suspension models: 21B Cast and 21B Fab. (See ReycoGranning InnovAir Warranty for models with axles.)

1. Coverage is per below in months or in miles depending upon which occurs first. *

MONTHS	MILEAGE	COVERAGE PROVIDED
0-12	0-100,000	Cost of Parts and Labor Allowance
13-60	100,001-500,000	100% Cost of Parts Only

*Products designed and used for off-road have six months or 50,000-mile coverage only.

2. This warranty shall not apply and no warranty of any kind shall exist as to any product which has been subject to abuse, misuse, neglect, misapplication or accident of any type or cause or which has been repaired, replaced, substituted or used with parts other than genuine parts of The Company or has been altered by anyone.

3. The Company shall not be liable for the loss of use of any product, loss of time, inconvenience, commercial loss or any other indirect consequential, special or incidental damages due to breach of the above warranty of any other failure to comply with the terms of the contract between The Company and The Buyer, The Company makes no warranties of any kind, express or implied, other than as herein expressly provided, and specifically disclaims the implied warranties of merchantability and fitness for a particular purpose.

4. With respect to parts manufactured by others, The Company shall have no duty except to assign to the buyer any claim which The Company may have against the manufacturer thereof. (TTT warrants purchased components to the same extent as the Warranty extended by the original manufacturer to TTT). This warranty does not apply to the normal "wearing out" of rubber bushings, shock absorbers, etc., or sacrificial wear areas such as springs to hangers.

5. The determination of the reasonable cost of labor as required in paragraph one (1), shall be made in accordance with the TTT shop standard times. Maximum hourly allotment for labor cost is determined by TTT annually. Shop standard times and the maximum hourly allotment for labor cost may be revised periodically at the sole discretion of The Company.

6. The Company is not responsible for damages from improper installation or operations beyond design capability. The Company in its sole discretion shall determine whether or not any product is defective or otherwise covered by this warranty. No action for breach of this warranty may be commenced more than one year after the occurrence of alleged breach. This warranty is not transferable.

7. Retention of possession or use of the product for the warranty period shall constitute an unconditional acceptance thereof and fulfillment of all warranties and obligations of TTT and no assistance rendered by The Company in operating the product or remedying any defect either before or after that time shall operate to extend the warranty period.

PRODUCT INSTALLER RESPONSIBILITIES

8. Installer is responsible for installing the product in accordance with The Company specifications and installation instructions.

Installer is responsible for providing proper vehicle components and attachments as well as required or necessary clearance for suspension components, axles, wheels, tires, and other vehicle components to ensure a safe and sound installation and operation.

Installer is responsible for advising the owner of proper use, service and maintenance required by the product and for supplying maintenance and other instruction as readily available from The Company.

PRODUCT OWNER RESPONSIBILITIES

9. Owner is solely responsible for pre-operation inspection, periodic inspections, maintenance, and use of the product as specified in the particular TTT instructions available by product model, except as provided in this warranty, and for maintenance of other vehicle components. Of particular importance is the re-torque of fasteners including axle u-bolts, torque rod bolts and track rod bolts. This re-torque must be performed within 90 days of the suspension being put in service. Owner is responsible for "down time" expenses, cargo damage, and all business costs and losses resulting from a warrantable failure.

WARRANTY CLAIM PROCEDURES

10. For a claim to be considered it must contain adequate documentation which states vehicle mileage, starting date, product model, where and how used, and a TTT Return Material Authorization Number. This claim must be made within six months of failure of the component. Such part or parts must be returned to TTT, transportation charges paid. TTT reserves the right to inspect any returned components to determine cause of defects.

The Road To Success Is Quality Customer Care...

Reyco
Granning
S U S P E N S I O N S

1-800-753-0050 (USA)

1-800-811-4011 (CAN)

1-417-837-0423 (Intn'l)

www.tuthill.com

CANADA

Grimsby, Ontario

241 South Service Road
Grimsby, Ontario L3M 1Y7
(800) 811-4011
(905)945-2234
Fax (905)945-5906

INDIANA

Brookston

9098 West 800 South, P.O. Box 600
Brookston, Indiana 47923
(800) 255-7824
Fax (219) 279-2390

MISSOURI

Springfield

2715 N. Airport Commerce, P.O. Box 2268
Springfield, MO 65803

(800)753-0050, Fax (800)753-1095

(417)862-4343, Fax (417)837-0401

International - (417) 837-0423, Fax (417) 837-0485

Mount Vernon

1205 Industrial Park Drive
Mount Vernon, MO 65712

(417)466-2178, Fax (417)466-3964