

Reyco Granning

S U S P E N S I O N S

TRAILER SUSPENSIONS



Model 21B & 21½B (Cast & Fab)

On/Off Highway Suspension System

Installation and Maintenance Instructions

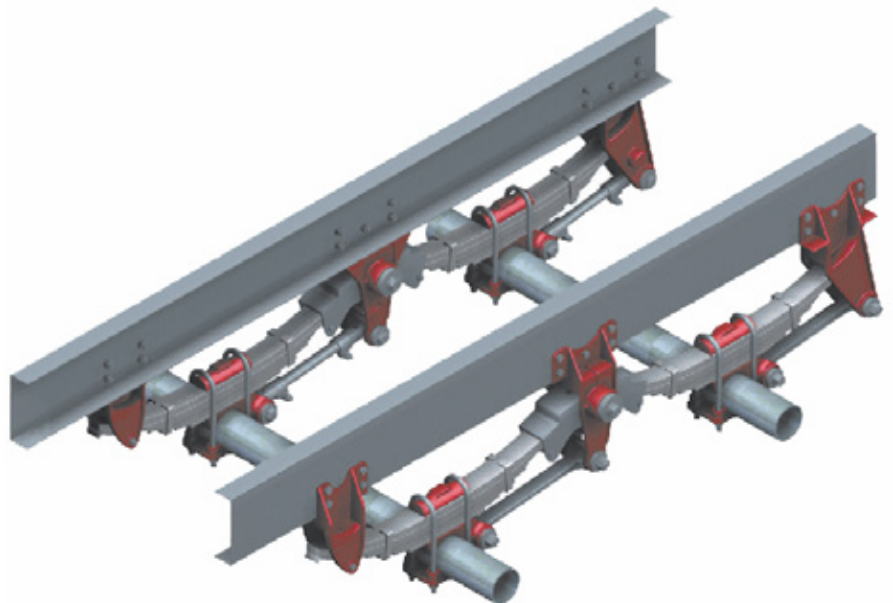

QVA

Quality: Providing worry-free reliability
Value: Exceeding customer expectations
Availability: Delivering on our promise, on time, every time

COMPANY PROFILE

Reyco Granning Suspensions was formed by the merger and acquisition of two well-known names in the heavy duty vehicle suspension industry—Reyco and Granning.

Reyco grew out of the Reynolds Mfg. Co and was first known as a major supplier of brake drums for heavy duty vehicles and later developed a full line of air and steel-spring suspensions for trucks, buses, trailers and motorhomes.

Granning Air Suspensions was founded in 1949 in Detroit, Michigan as a manufacturer of auxiliary lift axle suspensions. Granning later became an innovator of independent front air suspensions for the motorhome industry.

Reyco Granning manufacturing facilities are certified to the ISO 9001:2008 standards, a globally-recognized assurance that quality standards have been established and are maintained by regular rigorous audits.

Reyco Granning LLC was formed in early 2011 through a partnering of senior managers and MAT Capital, a private investment group headquartered in Long Grove, Illinois.

SAFETY PROCEDURES & INFORMATION	○ i.1
SAFETY FIRST	○ i.1
OPERATOR SAFETY	○ i.1
Lifting	○ i.1
Parts Handling	○ i.1
Welding	○ i.1
SUSPENSION SAFETY	○ i.2
Overloading the suspension	○ i.2
Torque	○ i.2
HANGER INFORMATION	○ i.3
HANGER INSTALLATION	○ i.4
WELDING INSTRUCTIONS FAB HANGERS	○ i.6
AXLE SEAT INSTALLATION	○ i.7
TORQUE ARM BUSHING ASSEMBLY INSTALLATION	○ i.9
AXLE TO HANGER ASSEMBLY INSTALLATION	○ i.11
SUSPENSION ALIGNMENT INSTRUCTIONS	○ i.12
SUSPENSION MOUNTING HEIGHT CHART	○ i.13

Installation Instructions Model 21B

SAFETY FIRST

Be sure to read and follow all installation and maintenance procedures.

LIFTING

Practice safe lifting procedures. Consider size, shape and weight of assemblies. Obtain help or the assistance of a crane when lifting heavy assemblies. Make sure the path of travel is clear.



PARTS HANDLING

When handling parts, wear appropriate gloves, eyeglasses and other safety equipment to prevent serious injury.

WELDING

When welding, be sure to wear all personal protective equipment for face and eyes, and have adequate ventilation. When welding, protect spring beams and air springs from weld spatter and grinder sparks. Do not attach "ground" connection to springs.

Under normal use, steel presents few health hazards. Prolonged or repeated breathing of iron oxide fumes produced during welding may cause siderosis.

NOTE: DO NOT WELD ADI Components.

Welding Helmet

Welding Apron

Welding Gloves

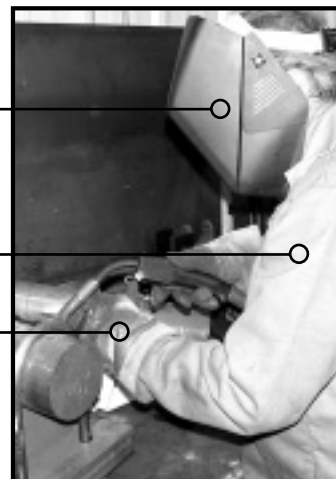

 **WARNING**

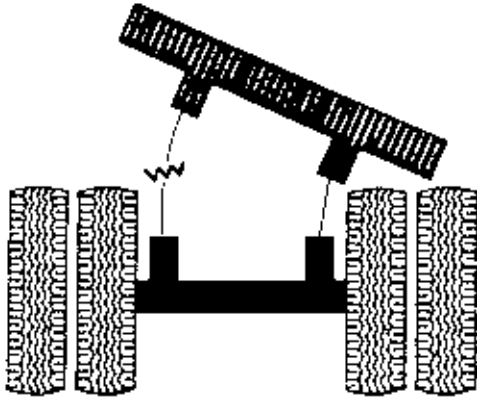

OVERLOADING

Overloading is the practice of transporting cargos that surpass the specified vehicle's ratings. Overloading can cause component failure, resulting in accidents and injuries.



This symbol indicates to the reader to use caution when seen and to follow specific requirements or warnings stated.



CAUTION: Specific torque requirements are recommended.

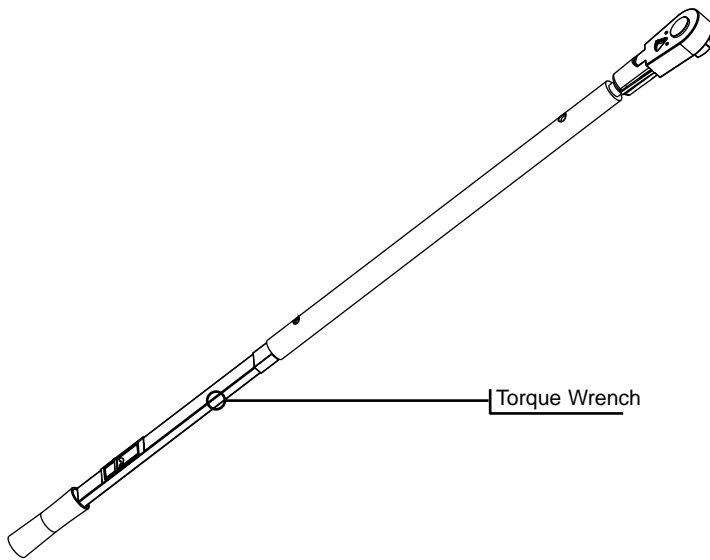

TORQUE

Proper tightening of the U-bolt nuts and alignment bolts are high priority items. A fastener system is considered "loose" any time the torque is found below required values. Failure to maintain the specified torque and to replace worn parts can cause component failure resulting in accident with consequent injury.

NOTE: It is extremely important after the first 1,000 to 3,000 loaded miles (1,600 - 4,800 kms) of operation, and with each annual inspection thereafter, that all of the bolt and nut tightening recommendations be followed. Any loose fasteners must be retorqued to comply with warranty requirements and to ensure long, trouble-free performance.

Installation Instructions Model 21B

HANGER INSTALLATION

Based on your axle spread requirement, determine the hanger center to center dimension, from drawings on pages **m.7** to **m.16**. Then, on the subframe, mark the centerline of the equalizer hanger (item 6) from the king pin. Typical axle spacing shown at right.

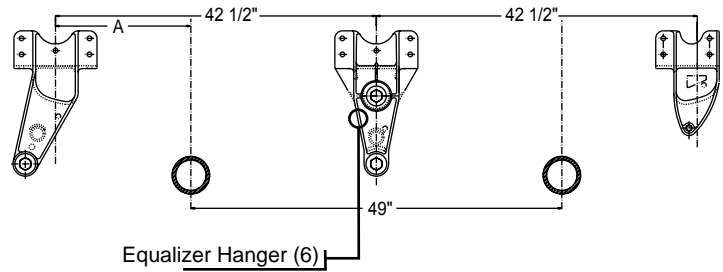

Cast hanger drawings (**i-5**) and Fab hanger drawings (**i-6**) provide typical detailed requirements for hanger installations. Before proceeding, please refer to these drawings for trouble-free maintenance.

From the equalizer locate the center line of the front (item 1, 2) and rear hangers (item 14, 15). Clamp the hangers in position. If bolt-on design is used, match-drill hole pattern of hangers and install fasteners. If weld-on design is used, tack weld hangers to sub-frame. Be sure the brackets are secure in both the horizontal and vertical planes and that the hangers are square in the frame. Hanger centers should be in line within 1/16". See pages **m.7** to **m.16** for proper spacing.

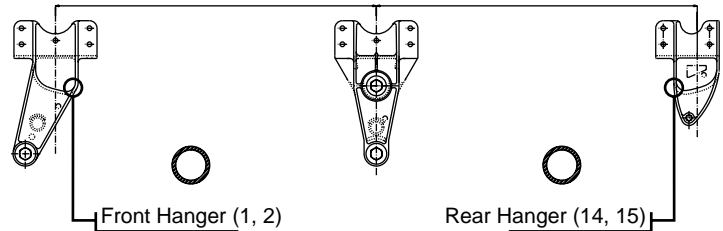

When bolting hangers to frame, use grade 8 hardware. When welding hangers to frame use AWS 70S wire or AWS E7018 electrode specifications for proper results see page **i.6**. Add 1.5" schedule 80 pipe cross tube steel pipe braces to front and center hangers.

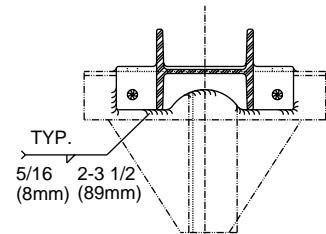

CAUTION: Specific welding procedures are required for installation.

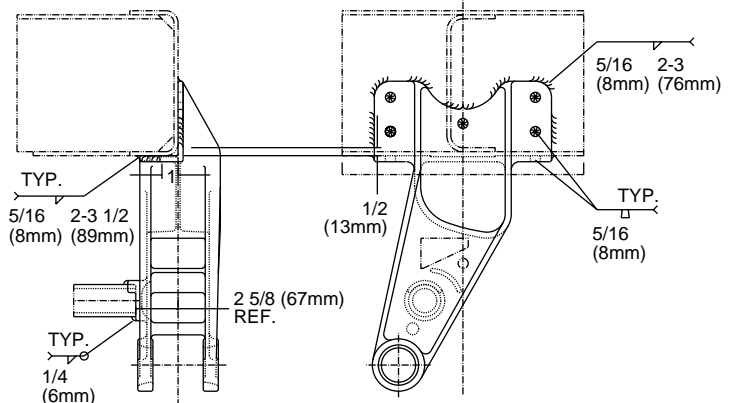

AWS Electrode Specification

- 1. Shielded Metal Arc (stick electrodes)E7018
- 2. Gas Metal Arc (MIG, solid wire)ER70S-X
- 3. Gas Tungsten Arc (TIG)ER70S-X
- 4. Flux Cored Arc (tubular wire).....E70T-X

INSTRUCTIONS FOR WELDING SUSPENSION HARDWARE TO FRAMES AND AXLES

Four methods may be used to weld components per American Welding Society (AWS) specifications.

NOTE: DO NOT WELD ADI Components.

The weld strength must be at 70,000 psi. Higher or lower strengths are not acceptable. The best fusion and strengths will be obtained using the voltage, current, and shielding medium recommended by the electrode manufacturer. If stick method is used, electrodes must be clean and dry, and stored per AWS Section 4.5.2.

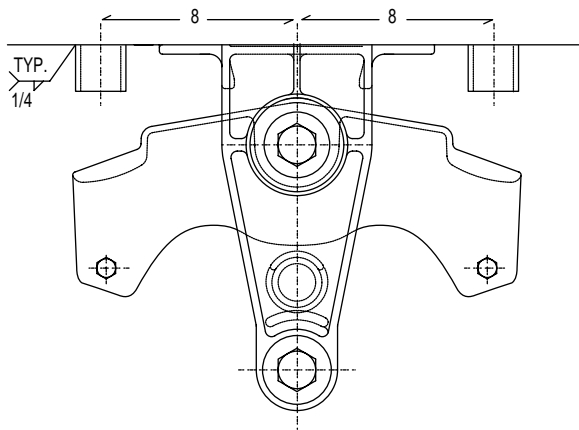

OPTIONAL UNDERFRAME BUMP STOP

An underframe bump stop is available to be welded to the frame. The part number is 24695-01 or as a kit, K700073 for one equalizer and TK4722 for 2 equalizers. See the diagram below for proper installation.

TRI-AXLE

Bump stops for multi-axle suspensions are highly recommended and are available as an option for tandem application.

NOTE: DO NOT WELD ADI Components.

Installation Instructions Model 21B

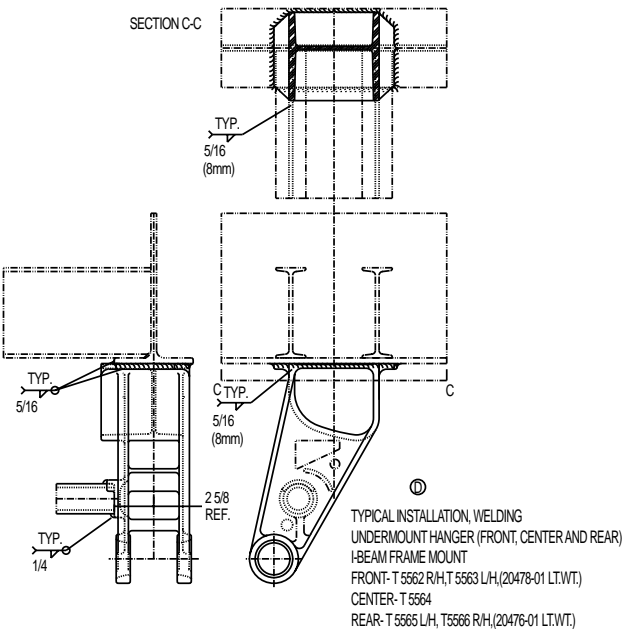
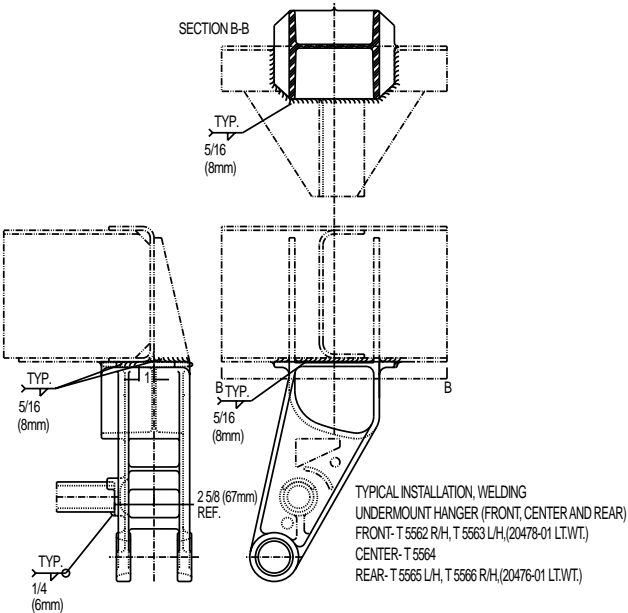
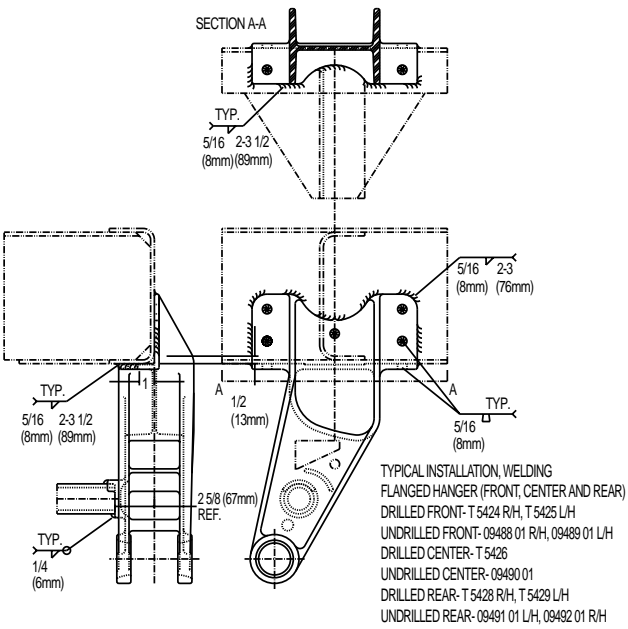

**WELDING INSTRUCTIONS
FABRICATED HANGERS**

1. Use AWS E7018 rod or equal for all welds.
2. Bracing shown is the minimum requirement. Heavy duty use may require additional bracing. Contact Reyco Granning for more information.
3. Pipe bracing shown is 1 1/2" (nom.) schedule 80 pipe.
4. Use 1/4" material for all gussets
5. If spring center line does not line up with center line of frame I-beam, adjust gusseting so that gussets extend to edges of top plate on all hangers.
6. Pipe brace between rear hangers is not necessary unless suspension is subjected to heavy-duty use.

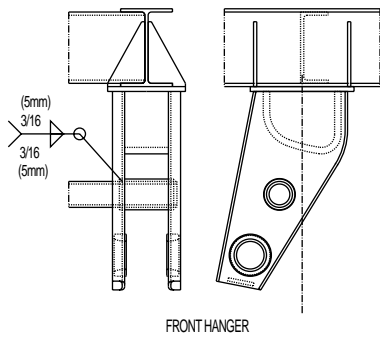

FRONT HANGER

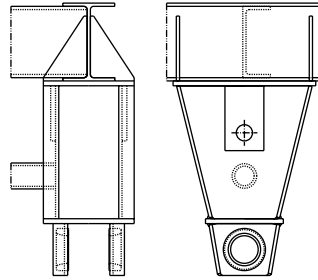

CENTER HANGER
50 INCH TO 65 INCH AXLE SPACING

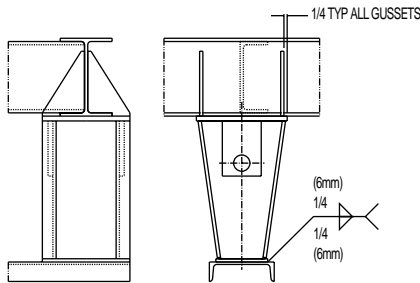

CENTER HANGER
72 INCH TO 100 INCH AXLE SPACING

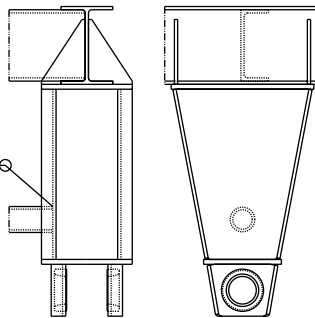

TORQUE ARM ATTACHMENT BRACKET
OPTIONAL FRONT EQUALIZER GUIDE TYPICAL

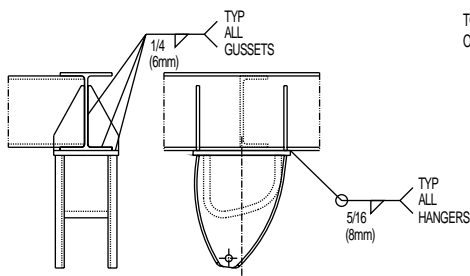

REAR HANGER

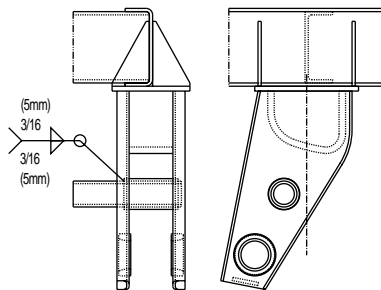

FRONT HANGER
INSTALLATION ON C-CHANNEL FRAME
TYPICAL FOR ALL HANGERS

Welding Instructions Fabricated Hangers

Installation Instructions Model 21B

BRAKE CAM LOCATION REQUIREMENTS

Brake camshafts are located to the rear of the axle within 20° of centerline. If camshafts are located differently, assembler must check for adequate clearances. Be sure that the axle seats which are selected provide brake chamber and brake camshaft assembly clearances. Location recommended is on center to 20° below center line.

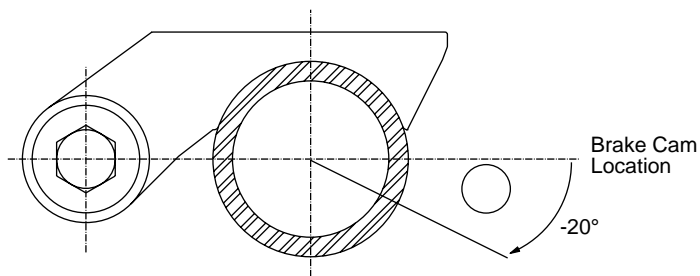

AXLE ASSEMBLY INSTALLATION

Position the axle seats (item 20) on the top side of axle at the correct spring center spacing (same as the transverse distance between hanger centerlines as mounted to the sub-frame).

The spring surface of the seats must be parallel to the ground. Clamp the seats in position securely and tack weld front and rear (not on the axle camber line).

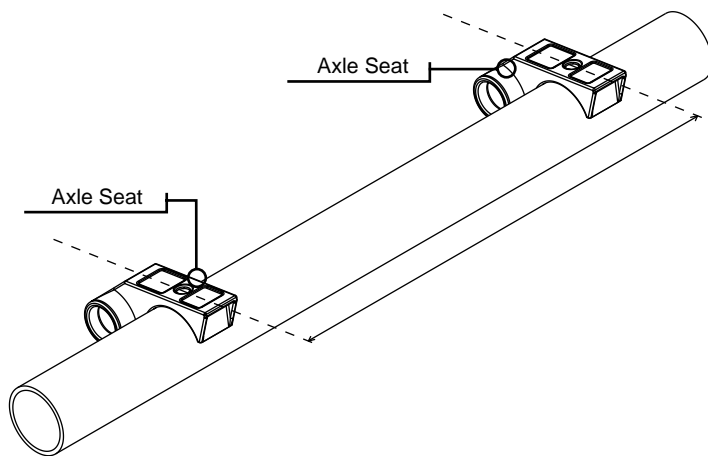

Axle Seat will be mounted on bottom side of axle for **Underslung** applications.

Weld the axle seat to the axle. Electrode must meet or exceed the requirements of AWS E7018. Do not weld 1 1/2" (38.1 mm) each side of the axle center line. At this point, the spring beams and u-bolts should not be attached to the seat.

NOTE: Refer to diagrams on page i.7 for welding detail.



CAUTION: Specific torque requirements are recommended.

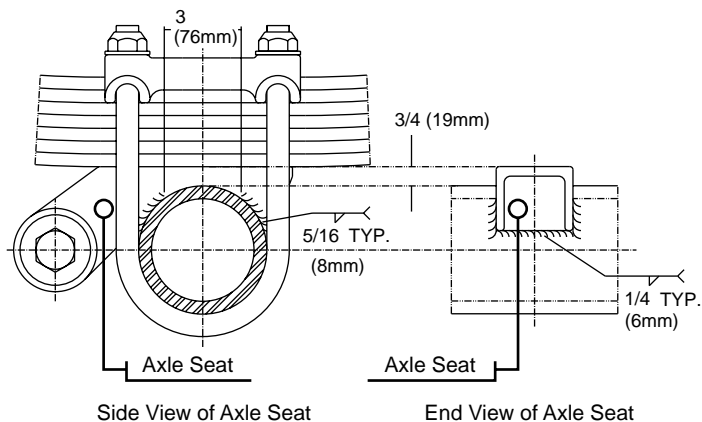

Position spring (item 13) on axle seat. See installation drawings (at end of book) for proper location of spring hook ends. Secure the spring in place with the top plate, u-bolts and nuts (items 5, 29 & 3) provided. Recheck springs for proper spring spacing and alignment. Tighten 3/4" or 7/8" u-bolts to 300-325 FP (410-440 NM) torque.

NOTE: Spring liners (additional) needed on the top side only on all 1-, 2- & 3-leaf springs. If axle seat spacers are used they must be welded to axle seat, front and rear.



CAUTION: Specific torque requirements are recommended.

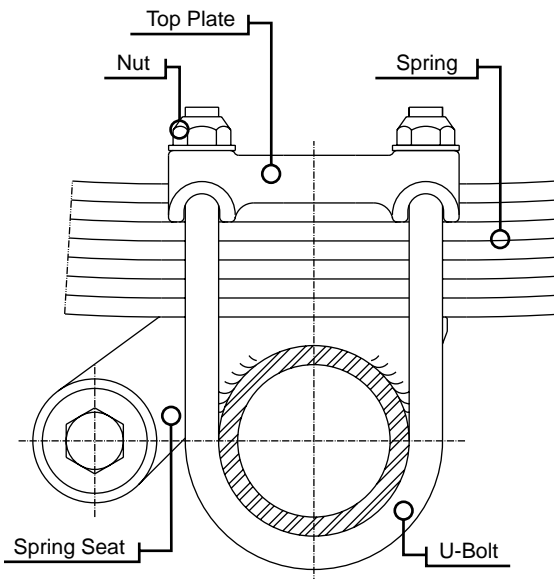

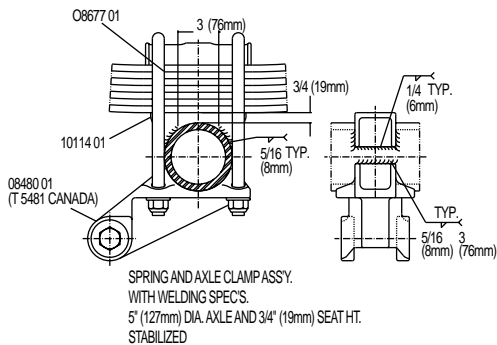
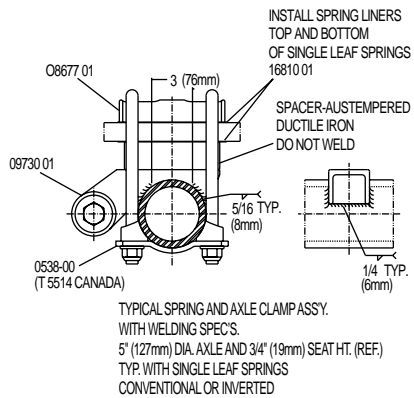
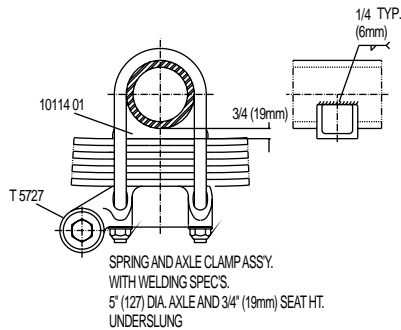
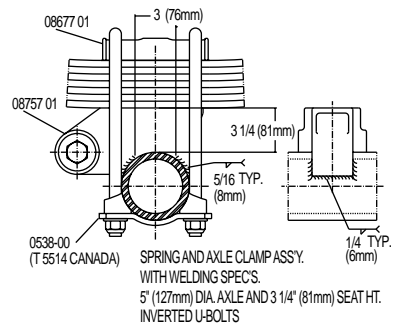
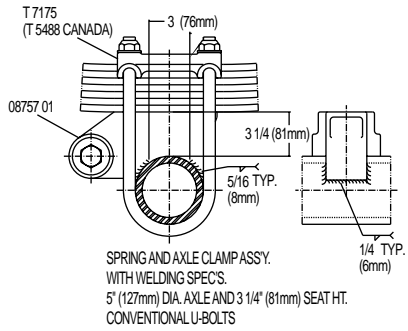
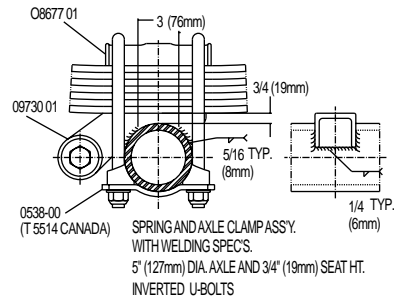
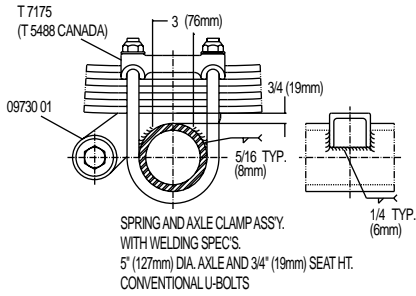

NOTE: LOW HYDROGEN WELDING ROD E-7016 OR EQUAL IAS RECOMMENDED.

Installation Instructions Model 21B

TWO-PIECE TORQUE ARM BUSHING ASSEMBLY PROCEDURE

Place Compression Washer and Rubber Bushing on head of Torque Arm bolt, and insert through openings in Hanger and through Torque Arm end opening. Lubricants ARE NOT recommended, but if absolutely necessary, use soap and water, or just plain water.

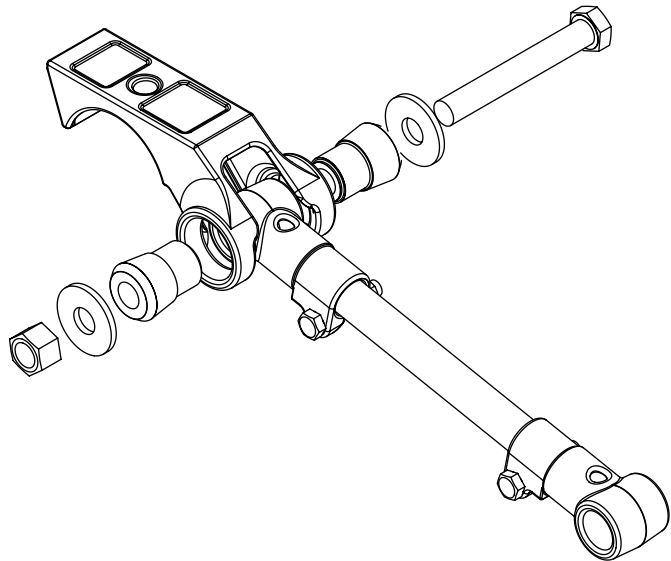

Do not use any Petroleum-Based Lubricants.

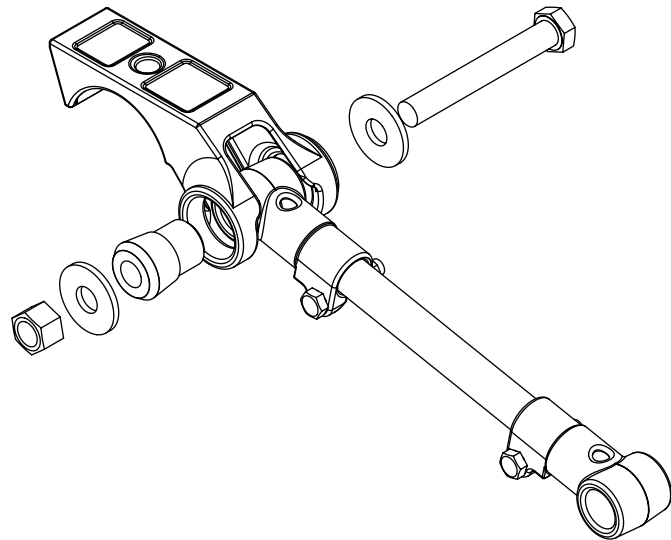

Place second Bushing, and second Compression Washer on other end of Torque Arm Bolt. Start Nut on Bolt by hand.

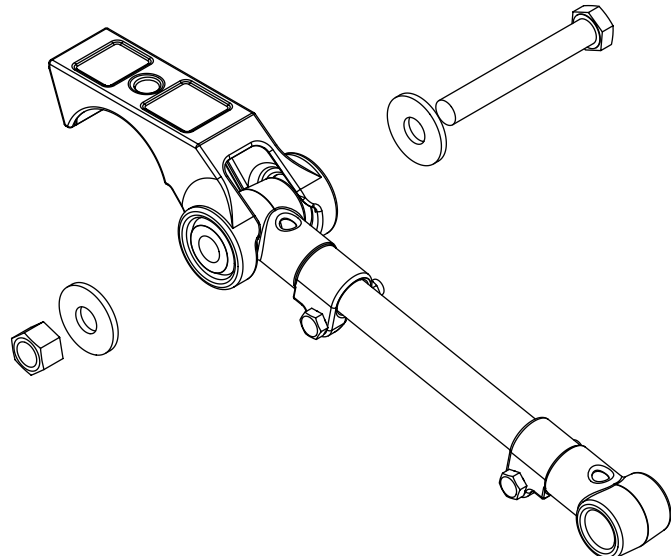

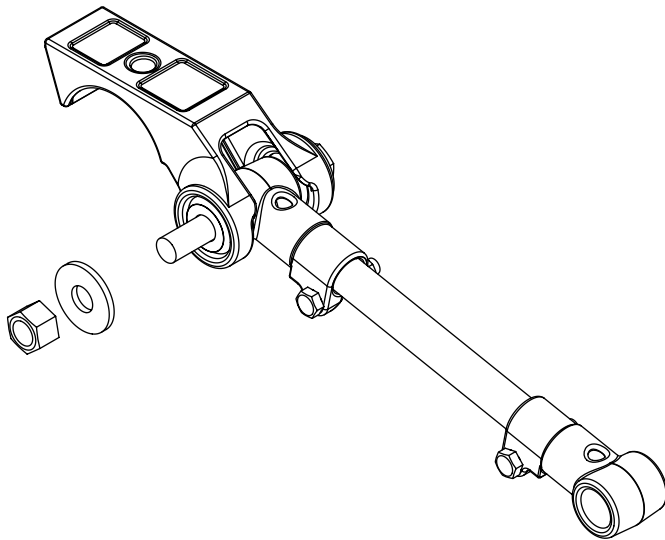

Tighten nut, partially, until all air gaps are removed between the two Compression Washers. Roughly center and hold the Torque Arm in the middle of the Hanger gap.

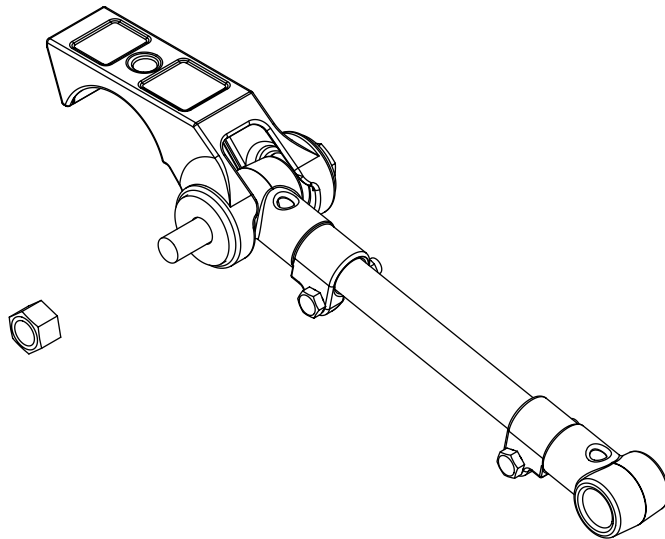

Slowly bring up the torque on the Locknut to approximately 140- 160 ft. lbs. (190-220 Nm) until the gap between the compression washer and the hanger or seat casting is 1/16" to 1/8". There should be an even buildup of rubber beads on each side of the Torque arm, and on each side of the Compression Washers. If the rubber is not built up, or if the Torque Arm is not centered, it is recommended to redo the above steps.

Do not keep tightening the nut, once the assembly is completed.

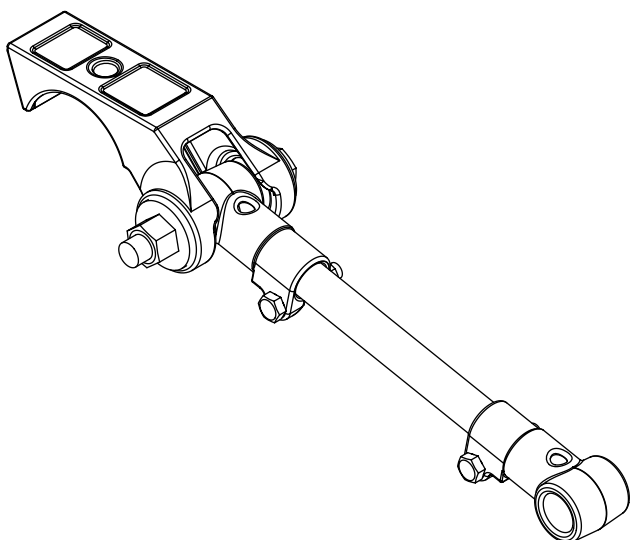

A subsequent check of the torque on the nut will be lower than 140 ft. lbs. (190 Nm), because of rubber settling. Make sure the assembly is snug and that there are no air gaps between washer, hangers and rubber bushings.

Do not retorque the 1" bolts after initial installation.

Installation Instructions Model 21B

AXLE TO HANGER ASSEMBLY INSTALLATION AND PRELIMINARY ALIGNMENT

Position the axle and spring assembly between the hangers. Secure the torque arms (adjustable on road, left side, item 30 or 31) and rigid on curb, right side, item 26 or 27) to the front (item 1 or 2) and center hangers (item 6). Install the spring rollers (item 19) and 1/2" bolts in the equalizer and where required in the rear hanger (item 14, 15).

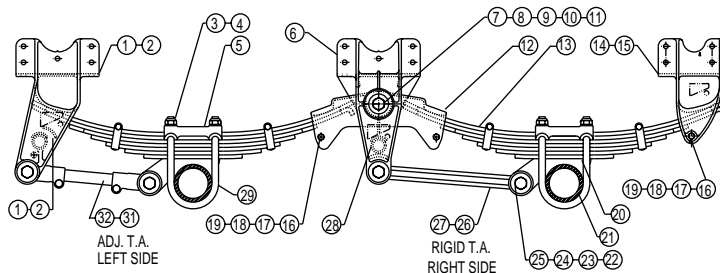

Check to see that springs are seated, interference-free, on all bearing surfaces. Install bolts to hold torque arms. **DO NOT TORQUE** at this time.

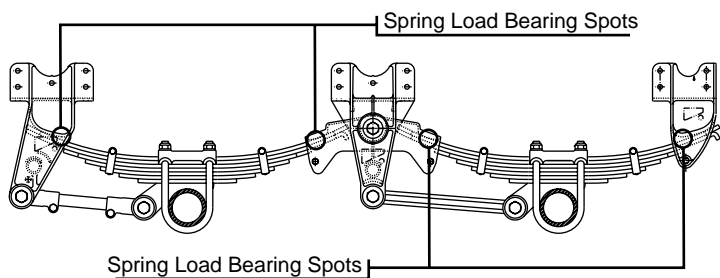

Install and tighten the 5/8" adjustable torque arm clamp nuts finger tight.

NOTE: Refer to appropriate drawing for axle number and type to identify proper item numbers.

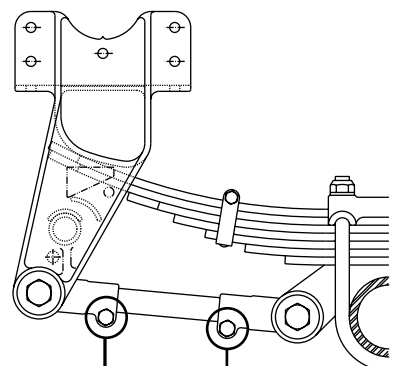

Adjustable Torque Arm Clamp Nuts



CAUTION: Specific torque requirements are recommended.

Position the frame at the desired mounting height and perform preliminary rough alignment by centering axle laterally, and aligning axles squarely with respect to frame to within 1/4" (6.4 mm) (right and left compared). Torque arm attaching 1" bolts and nuts (supplied with the torque arms item 22 & 23) can now be torqued per instructions on pg. i.10. Do not tighten the adjustable eye end clamp bolts at this time. See next page.

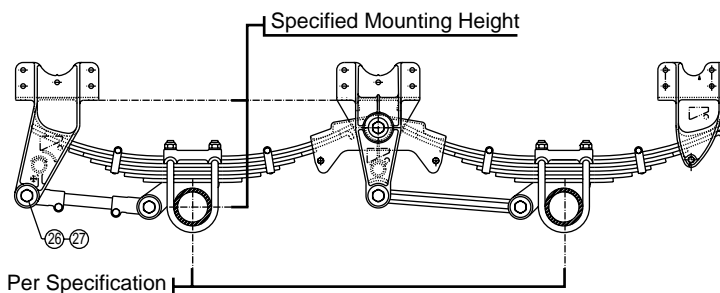

**FINAL AND IN SERVICE
SUSPENSION ALIGNMENT
INSTRUCTIONS**

The following steps are recommended and necessary for proper suspension alignment.

Release the brake system and pull the trailer forward while keeping to a straight line to free the suspension from binding. The ground must be level and smooth. The trailer brakes must remain released during alignment.

For best results the use of axle extensions and a "BAZOOKA" type king pin post, or a suitable optical alignment device are recommended. Align the front axle by lengthening or shortening adjustable torque arm (located on left side of trailer) with the king pin as shown in the sketch.

When the front axle is aligned to the kingpin to +/- 1/8" tighten the 5/8" torque arm clamp nuts on the front axle to 125-150 FP (170-205 Nm)



CAUTION: Specific torque requirements are recommended.

Align the rear axle to the front axle to +/- 1/16".

NOTE: Left side and right side axle measurements should be equal to within +/- 1/16". When the axles are aligned, tighten the adjustable torque arm clamp nuts on the rear axle to 125-150 FP (170-205 Nm).



CAUTION: Specific torque requirements are recommended.

After an initial loaded run-in period of approximately 1,000 miles, (1600 km) the alignment should be rechecked and corrected if necessary.

FP = Foot-Pounds; Nm = Newton-Meters

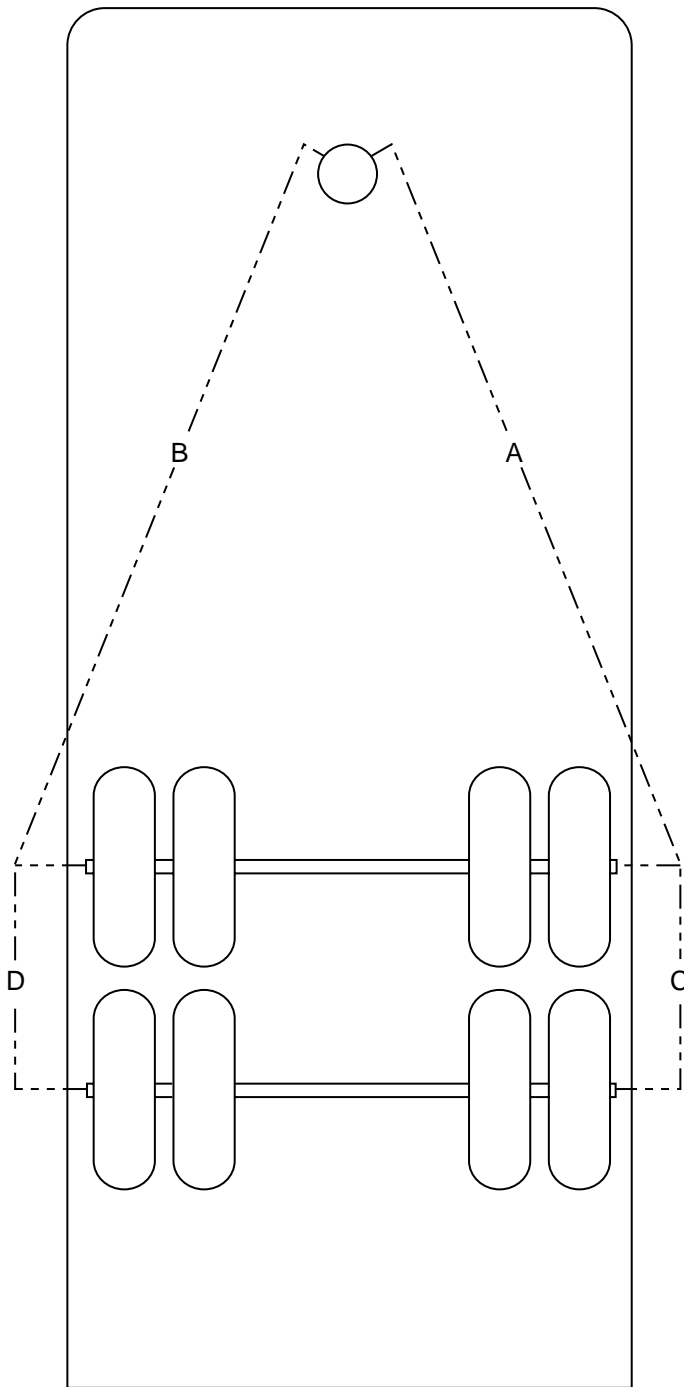

$A = B \pm 1/8$
 $C = D \pm 1/16$

Reyco Granning 21B "W" Suspension Mounting Height Chart

21B-W Single axle "00", 42", ** 44", ** 49", 54", 60", 65", 72", 109" Axle Spacings

Standard Mounting Heights (Inches)

Control # / Price Options Designation	Control Position		Standard Mounting Heights (Inches)												
	Spring ID Letter	# of leaves	Capacity Lbs.	3/4" Axle Seat Group	1 1/4" Axle Seat Group	1 3/4" Axle Seat Group	2 1/4" Axle Seat Group	2 3/4" Axle Seat Group	3 1/4" Axle Seat Group	3 1/4" Axle Seat Group	4 1/4" Axle Seat Group	4 3/4" Axle Seat Group	5 1/4" Axle Seat Group	5 3/4" Axle Seat Group	6 1/4" Axle Seat Group
0837601	E	3	11,000	14.50	15.00	15.50	16.00	16.50	17.00	17.50	18.00	18.50	X	X	X
T3564	N	8	11,000	14.50	15.00	15.50	16.00	16.50	17.00	17.50	18.00	18.50	X	X	X
T5597	R	8	11,000	15.50	16.00	16.50	17.00	17.50	18.00						
T5555	A	1	11,000	X	X	13.50	14.00	14.50	15.00	15.50	16.00	16.50	17.00	17.50	18.00
TT297**	B	1	11,000	X	X	13.50	14.00	14.50	15.00	15.50	16.00	16.50	17.00	17.50	18.00
1563601	C	1	12,500	14.00	14.50	15.00	15.50	16.00	16.50	17.00	17.50	18.00	18.50	X	X
2151101	F	3	12,500	14.50	15.00	15.50	16.00	16.50	17.00	17.50	18.00	18.50	X	X	X
TT452	S	9	13,000	14.50	15.00	15.50	16.00	16.50	17.00	17.50	18.00	18.50	X	X	X
Any Other Spring	Z														

Under-Slung (Springs Mounted Below Axle)

0837601	E	3	11,000	5.50
T3564	N	8	11,000	4.00
T5597	R	8	11,000	5.00
T5555	A	1	11,000	4.50
TT297**	B	1	11,000	N/A
1563601	C	1	12,500	6.00
2151101	F	3	12,500	5.00
TT452	S	9	13,000	3.50
Any Other Spring	Z			

** NOTE 42" AND 44" AXLE SPACINGS USE ONLY TT297 SPRING. TT297 SPRING NOT STANDARD FOR OTHER AXLE SPACINGS

CAST HANGERS MAINTENANCE SCHEDULE _____ ○ m.1
 Maintenance Schedule _____ ○ m.1
 Torque Requirements _____ ○ m.1
 Visual Inspection _____ ○ m.1

FAB HANGERS MAINTENANCE SCHEDULE _____ ○ m.2
 Maintenance Schedule _____ ○ m.2
 Torque Requirements _____ ○ m.2
 Visual Inspection _____ ○ m.2

TROUBLE SHOOTING GUIDE _____ ○ m.3
 Fasteners _____ ○ m.3
 Spring Alignment _____ ○ m.3
 Bushings _____ ○ m.3

NOTES _____ ○ m.4

BILL OF MATERIAL _____ ○ m.5
 63159-2 _____ ○ m.6
 Bill of material _____ ○ m.7

SUSPENSION DRAWINGS _____ ○ m.8
 98034-2 & 3 _____ ○ m.8
 63296-2 & 66128-2 _____ ○ m.9
 63159-2 & 3 _____ ○ m.10
 98033-2 & 63159-1 _____ ○ m.11
 74117-2 & 70100-2 _____ ○ m.12
 87188-2 & 83006 _____ ○ m.13
 84164 & 87187-2 _____ ○ m.14
 73129-2 & 74021 _____ ○ m.15
 84101 & 83005 & 84166 _____ ○ m.16

Maintenance Instructions Model 21B

MODEL 21B MAINTENANCE INSTRUCTIONS (CAST HANGERS)

The ReycoGranning Model 21B Leaf Spring Suspension, by design requires minimum maintenance. Suspensions require periodic checks to assure continued trouble-free performance.

21B RECOMMENDED MAINTENANCE SCHEDULES

1. Pre-service inspection.
2. First service inspection, after 1,000-3,000 miles, (1600-4800 KM).
3. PM Inspections, coincidental with DOT "C" Inspections-Annually.
4. During replacement of any service parts.
5. Upon discovery of any loose components.

TORQUE REQUIREMENTS

Verify with each scheduled inspection.

1. Tighten 3/4" or 7/8" U-bolt nuts—300-325 FP, (410-440 Nm).
2. There is no need to retorque the Torque Arm 1" bolts after correct initial installation.
3. Tighten 5/8" torque arm clamp nuts—125-150 FP, (170-205 Nm).
4. Tighten 1" equalizer capscrews—400-450 FP, (540-610 Nm).
5. Tighten 1/2" spring retainer nuts—75-80 FP, (105-110 Nm).

VISUAL INSPECTION

1. Loose or missing fasteners.
2. Cracks in hangers or axle connection brackets.
3. Springs, centered in hangers and equalizers.
4. Inspect torque arm bushings for wear.

If any of the above defects are noted, have vehicle checked by a qualified mechanic. Torque values are specified with clean, lightly oiled fasteners, and should only be verified with a calibrated torque wrench. Failure to follow these instructions could void the warranty and could result in subsequent injury.

FP = Foot-Pounds; Nm = Newton-Meters

MODEL 21B MAINTENANCE INSTRUCTIONS (FAB HANGERS)

The ReycoGranning Model 21B Leaf Spring Suspension, by design requires minimum maintenance. Suspensions require periodic checks to assure continued trouble-free performance.

21B RECOMMENDED MAINTENANCE SCHEDULES

1. Pre-service inspection.
2. First service inspection, after 1,000-3,000 miles, (1600-4800 KM).
3. PM Inspections, coincidental with DOT "C" Inspections-Annually.
4. During replacement of any service parts.
5. Upon discovery of any loose components.

TORQUE REQUIREMENTS

Verify with each scheduled inspection.

1. Tighten 3/4" or 7/8" U-bolt nuts—steel springs—300-325 FP, (410-440 Nm).
2. Tighten 3/4" or 7/8" U-bolt nuts—composite springs—250 FP, (340 Nm).
3. Tighten 1 1/4" equalizer shaft fastener nuts—575-625 FP, (780-850 Nm).
4. Tighten 2 1/2" equalizer shaft fastener nuts—F.W.WB 54"-65 1/2" —300-325 FP, (410-440 Nm).
5. Tighten 1 1/2" equalizer shaft fastener nuts—F.W.WB 72"-109" —200-225 FP, (270-305 Nm).
6. There is no need to retorque the Torque Arm 1" bolts after correct initial installation.
7. Tighten 5/8" torque arm clamp nuts—125-150 FP, (170-200 Nm).
8. Tighten 3/4" torque arm clamp nuts—175-200 FP, (236-270 Nm).
9. Tighten 1/2" spring retainer nuts—60-80 FP, (80-110 Nm).

VISUAL INSPECTION

1. Loose or missing fasteners.
2. Cracks in hangers or axle connection brackets.
3. Springs, centered in hangers and equalizers.

If any of the above defects are noted, have vehicle checked by a qualified mechanic. Torque values are specified with clean, lightly oiled fasteners, and should only be verified with a calibrated torque wrench. Failure to follow these instructions could void the warranty and could result in subsequent injury.

FP = Foot Pounds, Nm=Newton/Meters

Maintenance Instructions Model 21B

FASTENERS

Loose fasteners need immediate attention. Check components for wear and be sure holes are not worn or egg shaped. When replacing, be sure threads are clean, lightly oiled and not deformed. Consult the maintenance section for the correct torque specification. To insure an accurate torque reading, the torque tool used for checking torque, must provide a correct measurement.

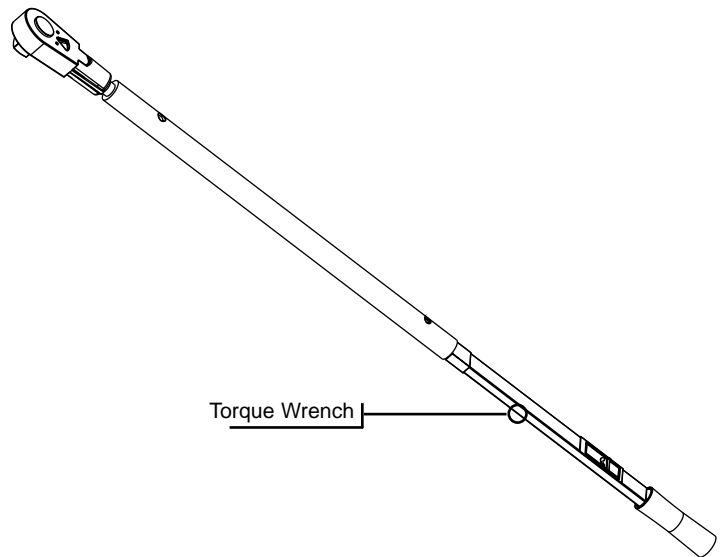

BUSHINGS

Inspect rubber bushings for large splits, tears and major wear. Rubber is attacked by sun, oils and greases. Replace any bushings which have noted damage.

Use a non-petroleum rubber lubricant, water or soap and water.

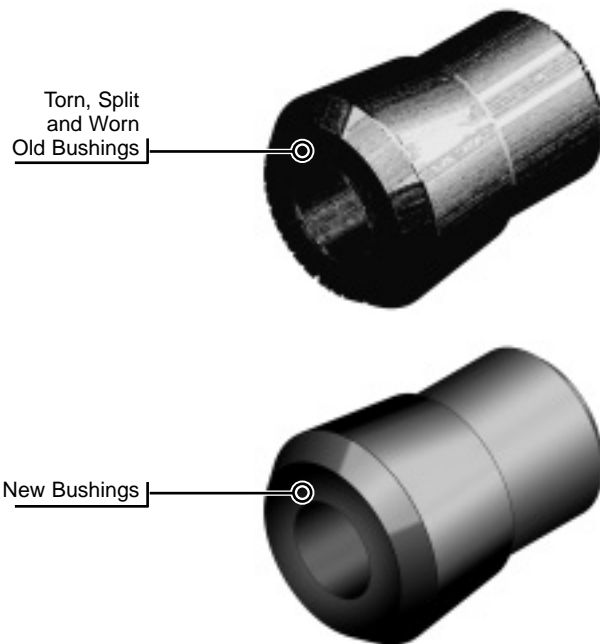

MAINTENANCE KIT

The following item numbers will help when maintaining parts for the model 21B suspension.

TK18997 - Torque Arm Rebush Kit - 21B (1) End

TK18998 - Equalizer Rebush Kit - 21B (1) Equalizer

TK24125 - Two Wear Pad Kit (wm hm) - 21B (1) Hanger

Maintenance Instructions Model 21B

Drawing No. 63159-2 Parts List					
ITEM	PART NUMBER	Single Axle	Tandem Axle	Tri-Axle	DESCRIPTION
1	T5424	1	1	1	Front Hanger, Right
2	T5425	1	1	1	Front Hanger, Left
3	14344-01	8	16	24	Lock Nut 7/8"
4	20852-01	8	16	24	Washer 7/8"
5	Variable*	2	4	6	Top U-bolt Plate
6	T5426	0	2	4	Center Hanger
7	1424801	0	4	8	Equalizer Bolt 1"
8	1425001	0	4	8	Lockwasher 1"
9	T1724	0	4	8	Equalizer Compression Washer
10	T5524	0	4	8	Equalizer Bearing
11	1424701	0	2	4	Equalizer Shaft
12	21725-01	0	2	4	Equalizer
13	Variable*	2	4	6	Spring
14	T5428	1	1	1	Rear Hanger, Right
15	T5429	1	1	1	Rear Hanger, Left
16	T5544	2	6	10	Cap Screw 1/2" x 4 3/4"
17	T1704	2	6	10	Hex Nut 1/2"
18	T1705	2	6	10	Lockwasher 1/2"
19	T2106	2	6	10	Spring Roller
20	Variable*	2	4	6	Axle Seat
21	Not Furnished				Axle
22	T5492	4	8	12	Torque Arm Bolt
23	T5495	4	8	12	Lock Nut 1"
24	T2224	8	16	24	Torque Arm Washer
25	T5493	8	16	24	Torque Arm Bushing
26	15178-01	1	1	1	Torque Arm Rigid, Front 16 1/4" Curb Side
27	15179-01	0	1	2	Torque Arm Rigid, Rear 18 7/8" Curb Side
21	Not Furnished				Pipe Brace
29	Variable*	4	8	12	U-Bolt
30	15172-01	1	1	1	Torque Arm Adjst., Front 16 1/4" Road Side
31	15173-01	0	1	2	Torque Arm Adjst., Front 18 7/8" Road Side

* NOTE: Variables are listed on tables-on page 18.

SPRING SELECTION TABLE				
PART NO.	# LEAF	ARCH	CAPACITY	LENGTH
08376-01	3	Med.	11,000	42
12609-01	7	Med.	9,000	42 1/2
15636-01	1	Med.	12,500	42
18906-01	9	Med.	9,000	55
21511-01	3	Med.	12,500	42
T3086	7	Med.	9,000	42 1/4
T3564	8	Med.	11,000	42 1/4
T5547	7	High	9,000	42 1/2
T5555	1	Med.	11,000	42 7/10
T5592	8	Low	11,000	42 1/2
T5597	8	High	11,000	42 1/2
T7297	1	Med.	11,000	36 1/2
T7321	1	High	11,000	42.18
T7452	9	Med.	13,000	41 3/4

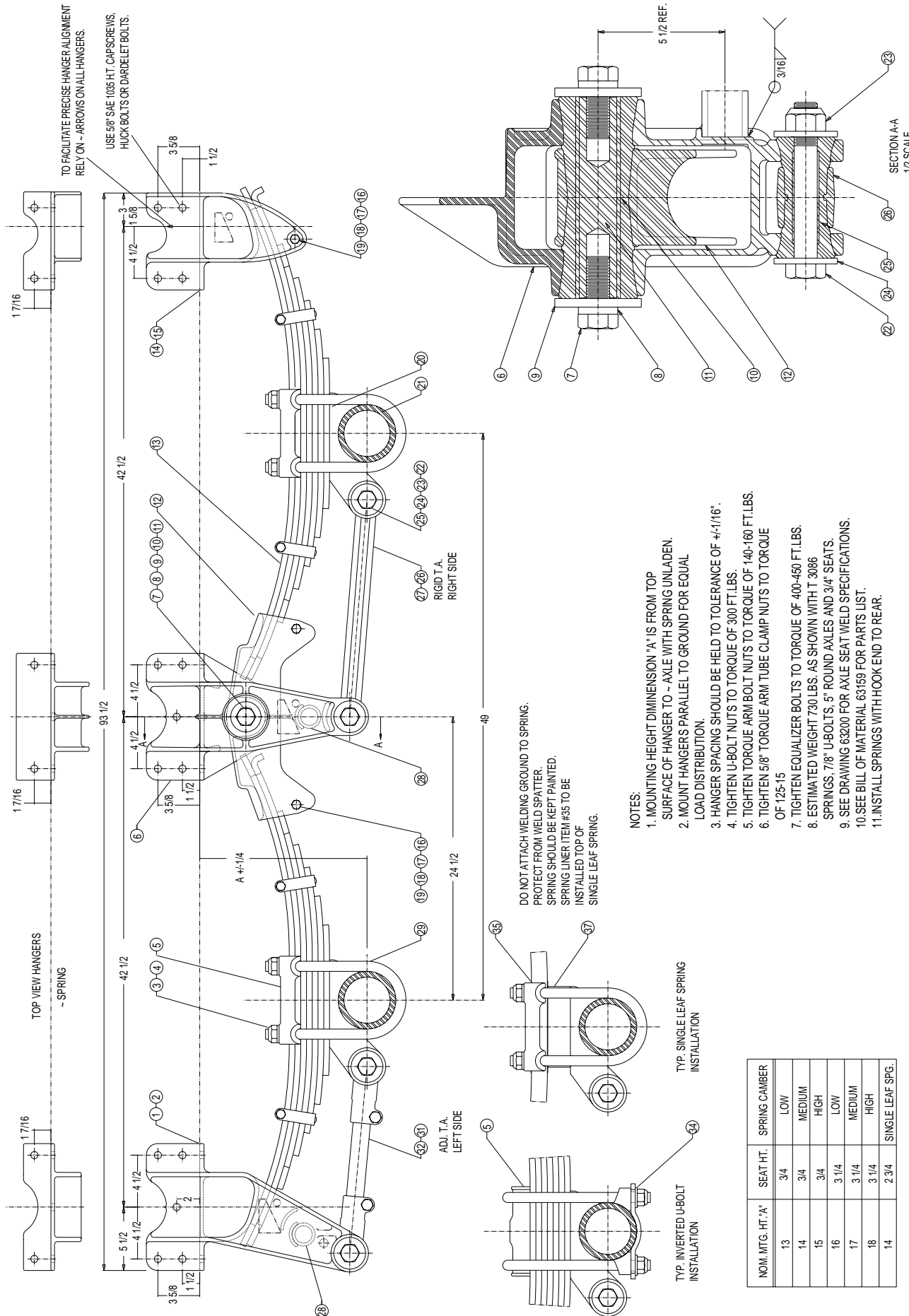

- NOTES:
1. MOUNTING HEIGHT DIMENSION "A" IS FROM TOP SURFACE OF HANGER TO - AXLE WITH SPRING UNLADEN.
 2. MOUNT HANGERS PARALLEL TO GROUND FOR EQUAL LOAD DISTRIBUTION.
 3. HANGER SPACING SHOULD BE HELD TO TOLERANCE OF +/- 1/16".
 4. TIGHTEN U-BOLT NUTS TO TORQUE OF 300 FT.LBS.
 5. TIGHTEN TORQUE ARM BOLT NUTS TO TORQUE OF 140-160 FT.LBS.
 6. TIGHTEN 5/8" TORQUE ARM TUBE CLAMP NUTS TO TORQUE OF 125-15
 7. TIGHTEN EQUALIZER BOLTS TO TORQUE OF 400-450 FT.LBS.
 8. ESTIMATED WEIGHT 730 LBS. AS SHOWN WITH T 3086 SPRINGS, 7/8" U-BOLTS, 5" ROUND AXLES AND 3/4" SEATS.
 9. SEE DRAWING 63200 FOR AXLE SEAT WELD SPECIFICATIONS.
 10. SEE BILL OF MATERIAL 63159 FOR PARTS LIST.
 11. INSTALL SPRINGS WITH HOOK END TO REAR.

NOM. MTG. HT. "A"	SEAT HT.	SPRING CAMBER
13	3/4	LOW
14	3/4	MEDIUM
15	3/4	HIGH
16	3 1/4	LOW
17	3 1/4	MEDIUM
18	3 1/4	HIGH
14	2 3/4	SINGLE LEAF SPG.

U-BOLT SELECTION TABLE					
LENGTH	PART NO.	LENGTH	PART NO.	LENGTH	PART NO.
11 1/2"	24213-115	13 1/2"	24213-135	15"	24213-150
12 1/2"	24213-125	14"	24213-140	16"	24213-160
13"	24213-130	14 1/2"	24213-145	17 1/2"	24213-175

All u-bolts on this table are 3/4"-14 x Length, with a 5" diameter bend.

ALL OTHER PARTS

Due to the large number of options and variety of specifications, all other parts are itemized in the Reyco Granning Price List. If there are any more questions, refer to Reyco Granning Customer Service 1-800-753-0050.

TYPICAL CLAMP GROUP PARTS TABLE (PARTS MOST USED)					
U-BOLT CLAMP STYLE	AXLE SIZE	TOP PLATE PART #	AXLE SEAT PART #	SEAT HEIGHT	BOTTOM PLATE PART #
Conventional	5"RD	T7175	0973001	3/4"	N.N.
		T7175	0875701	3 1/4"	N.N.
Inverted	5"RD	23334-01	0973001	3/4"	T5514
		23334-01	0973001	3/4"	053800
		23334-01	0875701	3 1/4"	053800
	5"SQ	23334-01	0798001	3/4"	0922901
		23334-01	0806001	3 1/4"	0922901
Inverted No Hop	5"RD	23334-01	10114-01	3/4"	T5481
Underslung	5"RD	23334-01	10114-01	3/4"	0848001
		NA	10114-01	3/4"	T5727
		NA	10114-01	3/4"	T5727

NOTES: Consult Reyco Granning Customer Service for current options. Spacers are used with above parts to get the various Mounting Heights.

SKETCHES OF U-BOLT CLAMP GROUP STYLES

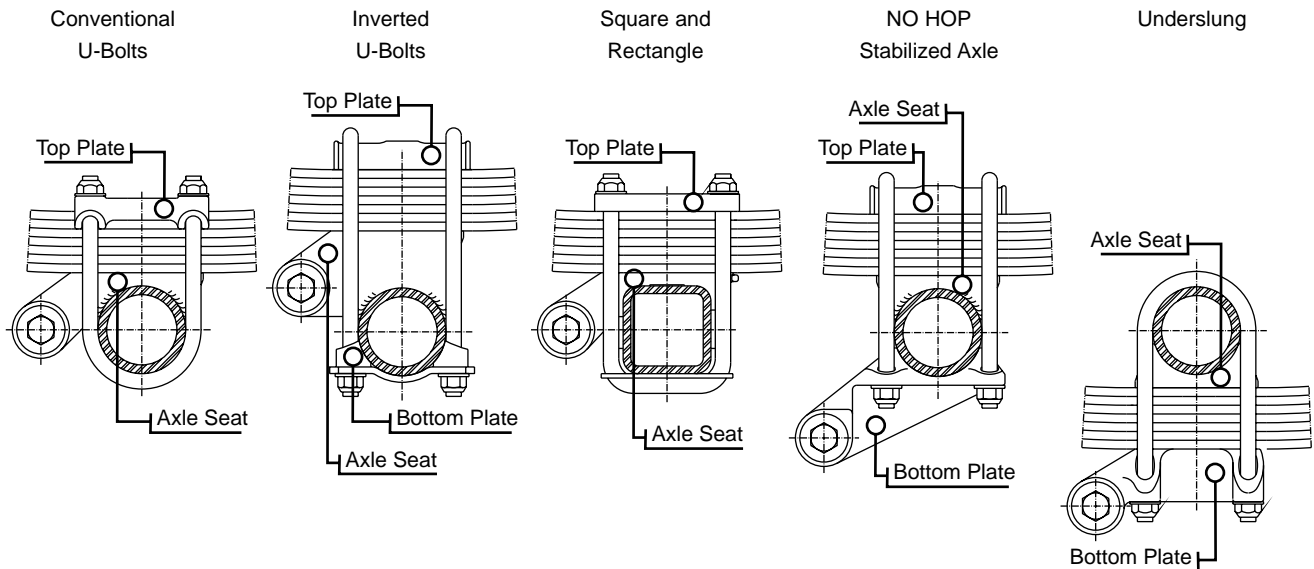

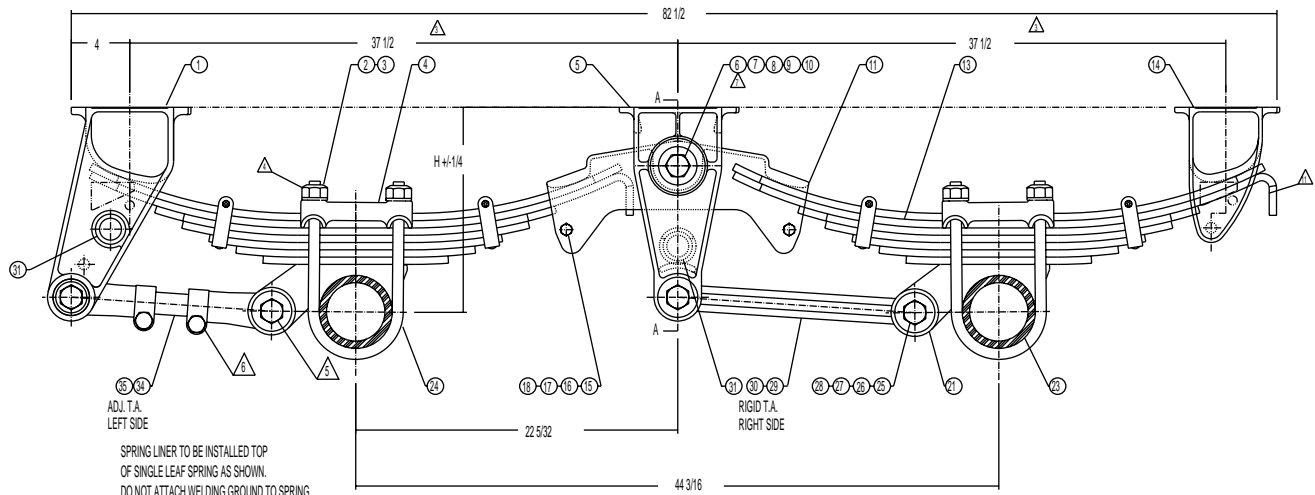

ADJ. T.A. LEFT SIDE

RIGID T.A. RIGHT SIDE

SPRING LINER TO BE INSTALLED TOP OF SINGLE LEAF SPRING AS SHOWN. DO NOT ATTACH WELDING GROUND TO SPRING. PROTECT SPRING FROM WELD SPATTER. SPRING SHOULD BE KEPT PAINTED.

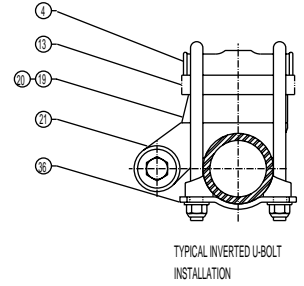

- NOTES:
1. MOUNTING HEIGHT "H" IS DIM. FROM TOP MOUNTING SURFACE OF HANGERS TO C.L. OF AXLE WITH NO LOAD ON UNIT.
 2. MOUNT HANGER BRKT'S. PARALLEL TO GROUND FOR EQUAL LOAD DISTRIBUTION.
 3. HOLD HANGER SPACING TO TOLERANCE OF $\pm 1/16"$.
 4. TIGHTEN $3/4"$ & $7/8"$ U-BOLT NUTS TO TORQUE OF 300-325 FT. LBS.
 5. TIGHTEN TORQUE ARM BOLT NUTS TO TORQUE OF 200 FT. LBS.
 6. TIGHTEN $5/8"$ TORQUE ARM TUBE CLAMP NUTS TO TORQUE OF 125-150 FT. LBS.
 7. TIGHTEN EQUALIZER BOLTS TO TORQUE 400-450 FT. LBS.
 8. SEE DWG. 63200 FOR AXLE SEAT WELD SPECS.
 9. SEE BIM 98034 FOR PARTS LIST.
 10. INSTALL SPRING WITH HOOKS TO REAR.

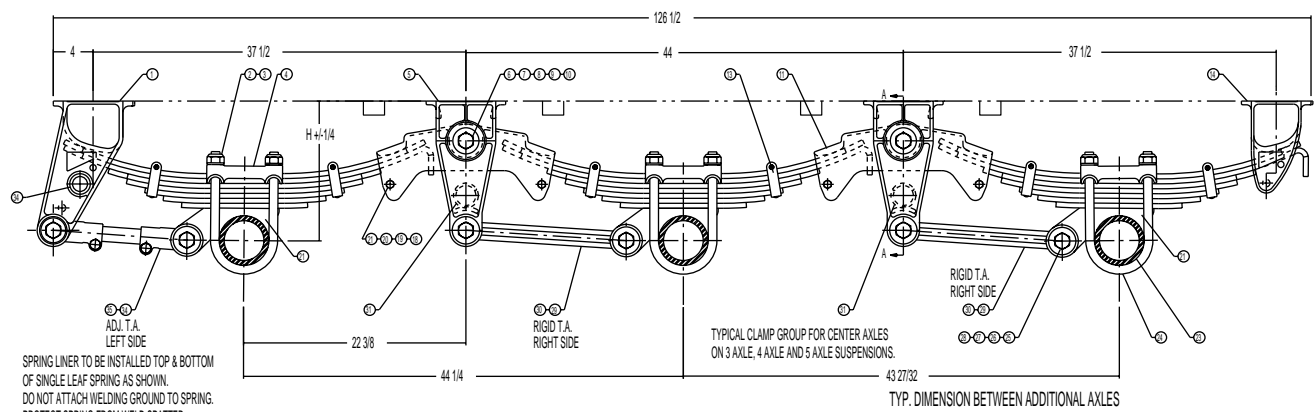
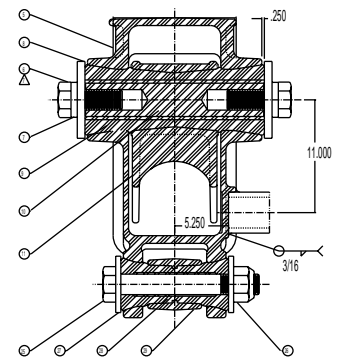

ADJ. T.A. LEFT SIDE

RIGID T.A. RIGHT SIDE

SPRING LINER TO BE INSTALLED TOP & BOTTOM OF SINGLE LEAF SPRING AS SHOWN. DO NOT ATTACH WELDING GROUND TO SPRING. PROTECT SPRING FROM WELD SPATTER. SPRING SHOULD BE KEPT PAINTED.

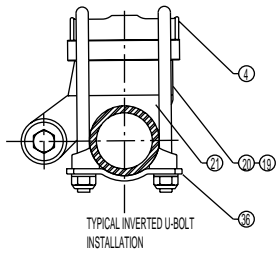

- NOTES:
1. MOUNTING HEIGHT DIM. IS FROM TOP OF HANGERS TO C.L. OF 5" RD. AXLE UNLADEN. 14" TO 18" AVAILABLE.
 2. MOUNT HANGERS PARALLEL TO GROUND FOR EQUAL LOAD DISTRIBUTION.
 3. TOLERANCE ON HANGER SPACING IS $\pm 1/16"$
 4. INSTALL SPRINGS WITH HOOK END TO REAR.
 5. SEE DRAWING 63200 FOR AXLE SEAT WELD SPECS.
 6. TIGHTEN U-BOLT NUTS TO TORQUE OF 300 FT. LBS.
 7. TIGHTEN EQUALIZER BOLTS TO TORQUE OF 450-500 FT. LBS.
 8. TIGHTEN TORQUE ARM BOLT NUTS TO TORQUE OF 140-160 FT. LBS.
 9. TIGHTEN $5/8"$ TORQUE ARM TUBE CLAMP NUTS TO TORQUE OF 125-150 FT. LBS.
 10. SEE BIM 98034 FOR PARTS LIST FOR EACH MOUNTING HEIGHT.

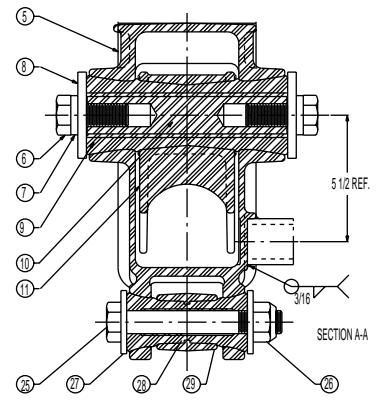

Maintenance Instructions Model 21B

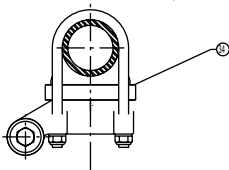
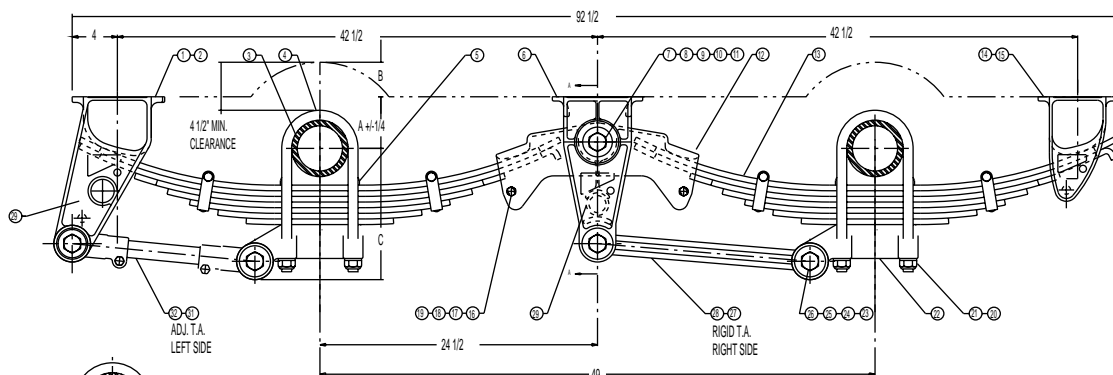

DO NOT ATTACH WELDING GROUND TO SPRING.
 PROTECT FROM WELD SPATTER.
 SPRING SHOULD BE KEPT PAINTED.
 SPRING LINER ITEM #35 TO BE
 INSTALLED TOP OF
 SINGLE LEAF SPRING.

- NOTES:
1. MOUNTING HEIGHT DIMENSION 'A' IS FROM TOP SURFACE OF HANGER TO CL. AXLE WITH SPRING UNLADEN.
 2. MOUNT HANGERS PARALLEL TO GROUND FOR EQUAL LOAD DISTRIBUTION.
 3. HANGER SPACING SHOULD BE HELD TO TOLERANCE OF $\pm 1/16"$.
 4. TIGHTEN U-BOLT NUTS TO TORQUE OF 300 FT.LBS.
 5. TIGHTEN TORQUE ARM BOLT NUTS TO TORQUE OF 140-160 FT.LBS.
 6. TIGHTEN 5/8" TORQUE ARM TUBE CLAMP NUTS TO TORQUE OF 125-150 FT.LBS.
 7. TIGHTEN EQUALIZER BOLTS TO TORQUE OF 400-450 FT.LBS.
 8. ESTIMATED WEIGHT 703.4 LBS. AS SHOWN WITH T 3086 SPRINGS, 3/4" U-BOLTS, 5" ROUND AXLES AND 3/4" SEATS.
 9. SEE DRAWING 63200 FOR AXLE SEAT WELD SPECIFICATIONS.
 10. SEE BILL OF MATERIAL 63296 FOR PARTS LIST.
 11. INSTALL SPRINGS WITH HOOK END TO REAR.
 12. DIM. 'B' IS CUT-OUT REQUIRED FOR MIN. CLEARANCE WITH 5" RD. AXLE.

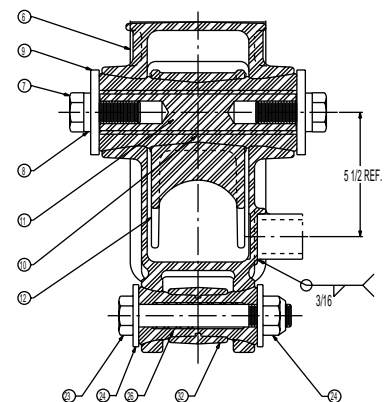

NOM. MTG. HT. 'A'	SEAT HT.	SPRING CAMBER	SPRING NO.	'B'DIM.	'C'DIM.
3	3/4	LOW	T 5532	4 1/2	11 5/8
4	3/4	MEDIUM	T 3086	3 1/2	11 5/8
5	3/4	HIGH	T 5547	2 1/2	11 5/8
3	3/4	LOW	T 5532	4 1/2	12 1/8
4	3/4	MEDIUM	T 3964	3 1/2	12 1/8
5	3/4	HIGH	T 5597	2 1/2	12 1/8
5	3/4	MEDIUM	08376 01	2 1/2	10 5/8
4	3/4	MEDIUM	T 7452	3 1/2	12 5/8
4	3/4	MEDIUM	T 5555	3 1/2	9 5/8
6	3/4	HIGH	15636 01	1 1/2	9 7/8

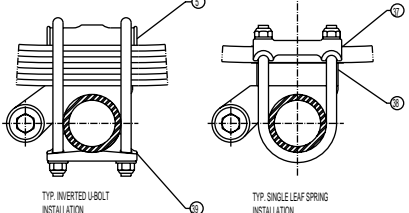
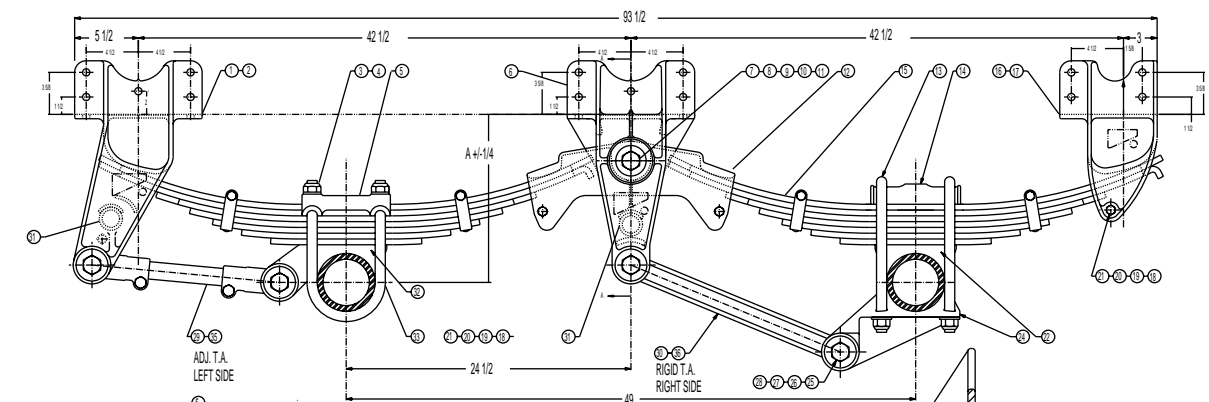

DO NOT ATTACH WELDING GROUND TO SPRING.
 PROTECT FROM WELD SPATTER.
 SPRING SHOULD BE KEPT PAINTED.
 SPRING LINER ITEM #35 TO BE
 INSTALLED TOP OF
 SINGLE LEAF SPRING.

- NOTES:
1. MOUNTING HEIGHT DIMENSION 'A' IS FROM TOP SURFACE OF HANGER TO - AXLE WITH SPRING UNLADEN.
 2. MOUNT HANGERS PARALLEL TO GROUND FOR EQUAL LOAD DISTRIBUTION.
 3. HANGER SPACING SHOULD BE HELD TO TOLERANCE OF $\pm 1/16"$.
 4. TIGHTEN U-BOLT NUTS TO TORQUE OF 300 FT.LBS.
 5. TIGHTEN TORQUE ARM BOLT NUTS TO TORQUE OF 140-160 FT.LBS.
 6. TIGHTEN 5/8" TORQUE ARM TUBE CLAMP NUTS TO TORQUE OF 125-150 FT.LBS.
 7. TIGHTEN EQUALIZER BOLTS TO TORQUE OF 400-450 FT.LBS.
 8. ESTIMATED WEIGHT 757 LBS. AS SHOWN WITH T 3086 SPRINGS, 7/8" U-BOLTS, 5" ROUND AXLES AND 3/4" SEATS.
 9. SEE DRAWING 63200 FOR AXLE SEAT WELD SPECIFICATIONS.
 10. SEE BILL OF MATERIAL 63159 FOR PARTS LIST.
 11. INSTALL SPRINGS WITH HOOK END TO REAR.

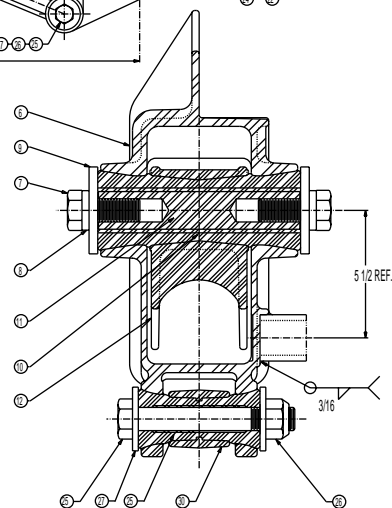

NOM. MTG. HT. 'A'	SEAT HT.	SPRING CAMBER
13	3/4	LOW
14	3/4	MEDIUM
15	3/4	HIGH
16	3 1/4	LOW
17	3 1/4	MEDIUM
18	3 1/4	HIGH
14	2 3/4	SINGLE LEAF SPG.

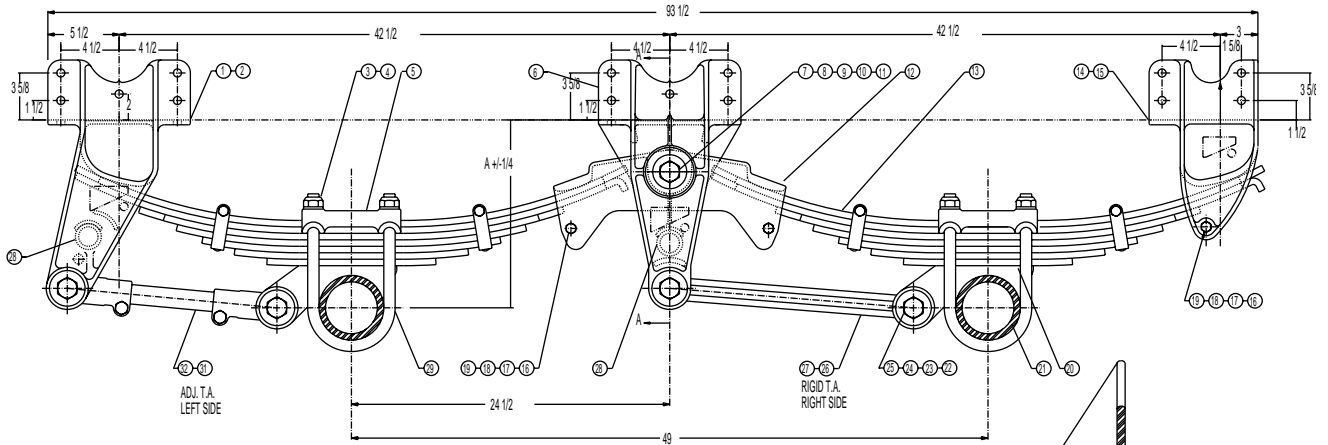

NOM. MTG. HT. "A"	SEAT HT.	SPRING CAMBER
13	3/4	LOW
14	3/4	MEDIUM
15	3/4	HIGH
16	3 1/4	LOW
17	3 1/4	MEDIUM
18	3 1/4	HIGH
14	2 3/4	SINGLE LEAF SPG.

- NOTES:**
- MOUNTING HEIGHT DIMENSION 'A' IS FROM TOP SURFACE OF HANGER TO - AXLE WITH SPRING UNLOADED.
 - MOUNT HANGERS PARALLEL TO GROUND FOR EQUAL LOAD DISTRIBUTION.
 - HANGER SPACING SHOULD BE HELD TO TOLERANCE OF $\pm 1/16"$.
 - TIGHTEN U-BOLT NUTS TO TORQUE OF 300 FT.LBS.
 - TIGHTEN TORQUE ARM BOLT NUTS TO TORQUE OF 140-160 FT.LBS.
 - TIGHTEN 5/8" TORQUE ARM TUBE CLAMP NUTS TO TORQUE OF 125-15
 - TIGHTEN EQUALIZER BOLTS TO TORQUE OF 400-450 FT.LBS.
 - ESTIMATED WEIGHT 730 LBS. AS SHOWN WITH T.3086 SPRINGS, 7/8" U-BOLTS, 5" ROUND AXLES AND 3/4" SEATS.
 - SEE DRAWING 63200 FOR AXLE SEAT WELD SPECIFICATIONS.
 - SEE BILL OF MATERIAL 63159 FOR PARTS LIST.
 - INSTALL SPRINGS WITH HOOK END TO REAR.

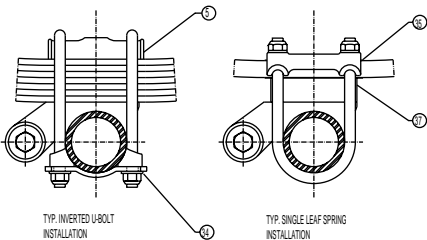
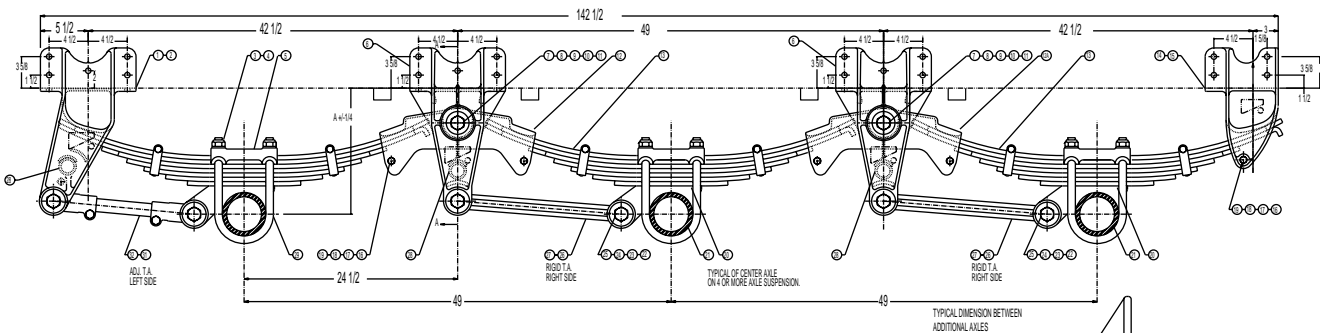
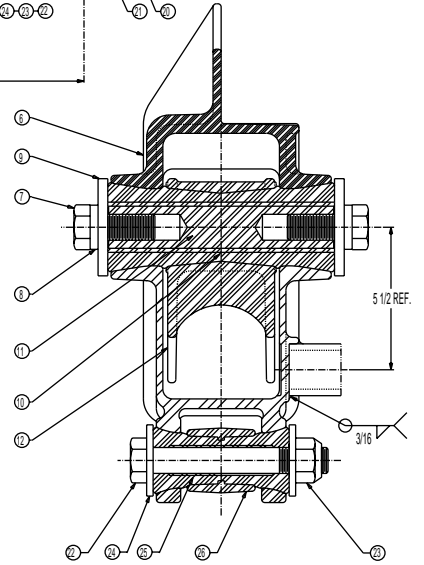

NOM. MTG. HT. "A"	SEAT HT.	SPRING CAMBER
13	3/4	LOW
14	3/4	MEDIUM
15	3/4	HIGH
16	3 1/4	LOW
17	3 1/4	MEDIUM
18	3 1/4	HIGH
14	2 3/4	SINGLE LEAF SPG.

- DO NOT ATTACH WELDING GROUND TO SPRING.
PROTECT FROM WELD SPATTER.
SPRING SHOULD BE KEPT PAINTED.
SPRING LINER ITEM #36 TO BE INSTALLED TOP OF SINGLE LEAF SPRING.
- NOTES:**
- MOUNTING HEIGHT DIMENSION 'A' IS FROM TOP SURFACE OF HANGER TO - AXLE WITH SPRING UNLOADED.
 - MOUNT HANGERS PARALLEL TO GROUND FOR EQUAL LOAD DISTRIBUTION.
 - HANGER SPACING SHOULD BE HELD TO TOLERANCE OF $\pm 1/16"$.
 - TIGHTEN U-BOLT NUTS TO TORQUE OF 300 FT.LBS.
 - TIGHTEN TORQUE ARM BOLT NUTS TO TORQUE OF 140-160 FT.LBS.
 - TIGHTEN 5/8" TORQUE ARM TUBE CLAMP NUTS TO TORQUE OF 125-150 FT.LBS.
 - TIGHTEN EQUALIZER BOLTS TO TORQUE OF 400-450 FT.LBS.
 - ESTIMATED WEIGHT 1056 LBS. AS SHOWN WITH T.3086 SPRINGS, 7/8" U-BOLTS, 5" ROUND AXLES AND 3/4" SEATS.
 - SEE DRAWING 63200 FOR AXLE SEAT WELD SPECIFICATIONS.
 - SEE BILL OF MATERIAL 63159 FOR PARTS LIST.
 - INSTALL SPRINGS WITH HOOK END TO REAR.

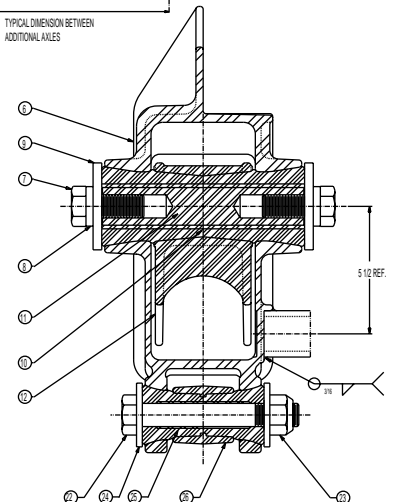

Drawing - 63159-2 & 3

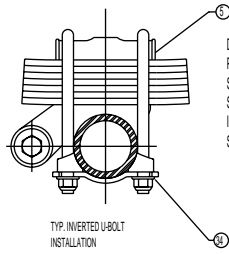
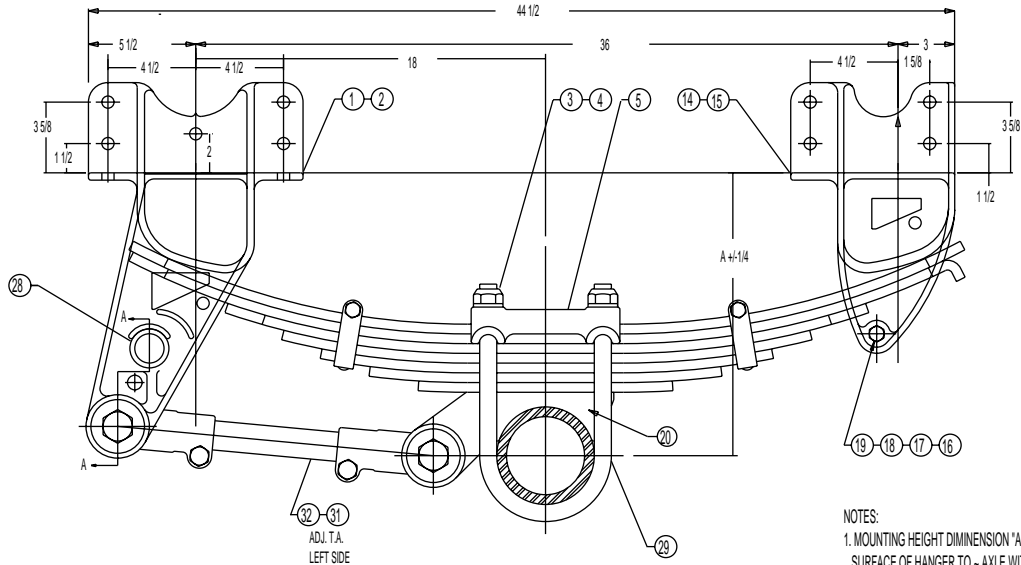

DO NOT ATTACH WELDING GROUND TO SPRING. PROTECT FROM WELD SPATTER. SPRING SHOULD BE KEPT PAINTED. SPRING LINER ITEM #36 TO BE INSTALLED TOP OF SINGLE LEAF SPRING.

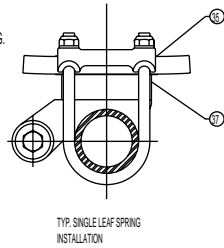

NOM. MTG. HT. "A"	SEAT HT.	SPRING CAMBER
13	3/4	LOW
14	3/4	MEDIUM
15	3/4	HIGH
16	3 1/4	LOW
17	3 1/4	MEDIUM
18	3 1/4	HIGH
14	2 3/4	SINGLE LEAF SPG.

- NOTES:
1. MOUNTING HEIGHT DIMENSION "A" IS FROM TOP SURFACE OF HANGER TO - AXLE WITH SPRING UNLADEN.
 2. MOUNT HANGERS PARALLEL TO GROUND FOR EQUAL LOAD DISTRIBUTION.
 3. HANGER SPACING SHOULD BE HELD TO TOLERANCE OF +/- 1/16".
 4. TIGHTEN U-BOLT NUTS TO TORQUE OF 300 FT.LBS.
 5. TIGHTEN TORQUE ARM BOLT NUTS TO TORQUE OF 140-160 FT.LBS.
 6. TIGHTEN 5/8" TORQUE ARM TUBE CLAMP NUTS TO TORQUE OF 125-150 FT.LBS.
 7. ESTIMATED WEIGHT 345 LBS. AS SHOWN WITH T 3086 SPRINGS, 7/8" U-BOLTS, 5" ROUND AXLES AND 3/4" SEATS.
 8. SEE DRAWING 63200 FOR AXLE SEAT WELD SPECIFICATIONS.
 9. SEE BILL OF MATERIAL 63159 FOR PARTS LIST.
 10. INSTALL SPRINGS WITH HOOK END TO REAR.

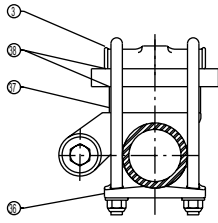
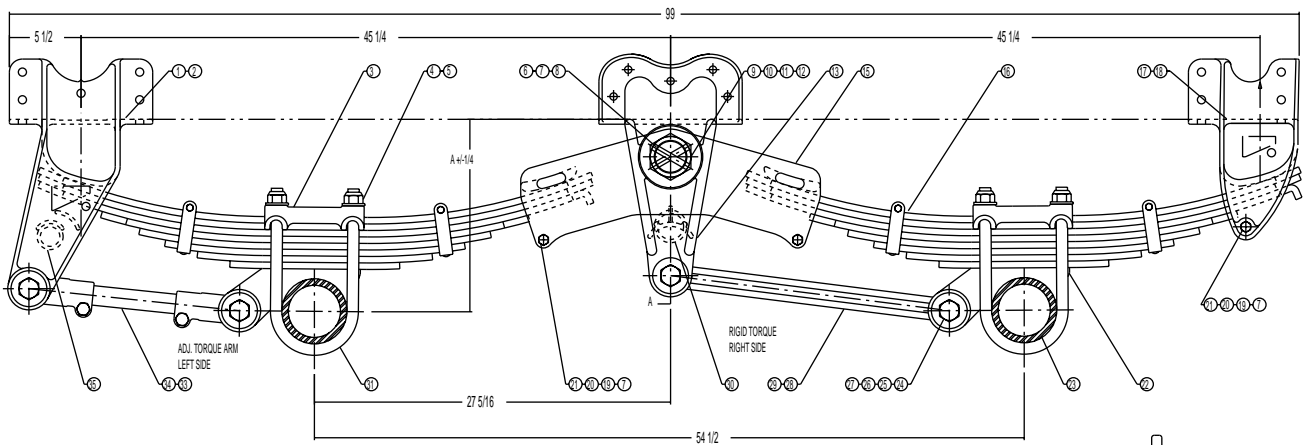

TYP. INSTALLATION SINGLE LEAF SPRING AND INVERTED U-BOLTS

INSTALL SPRING LINER TOP AND BOTTOM OF SINGLE LEAF SPRING.

DO NOT ATTACH WELDING GROUND TO SPRING. PROTECT FROM WELD SPATTER. SPRING SHOULD BE KEPT PAINTED.

NOMINAL MOUNTING HT. "A" DIM.	SEAT HT.	SPRING CAMBER
13	3/4	LOW
14	3/4	MED.
15	3/4	HIGH
14	2 3/4	MED. SING. LEAF
16	3 1/4	LOW
17	3 1/4	MED.
18	3 1/4	HIGH

NOTES:

1. MOUNTING HEIGHT "A" IS FROM BOTTOM OF FRAME TO - OF 5" RD. AXLE WITH NO LOAD ON TANDEM.
2. MOUNT HANGER BRACKETS PARALLEL TO GROUND FOR EQUAL LOAD DISTRIBUTION.
3. SPACING OF HANGER BRACKETS SHOULD BE HELD TO TOLERANCE OF $\pm 1/16"$.
4. TIGHTEN U-BOLT NUTS TO TORQUE OF 300FT.LBS.
5. TIGHTEN TORQUE ARM BOLT NUTS TO TORQUE OF 140-160 FT.LBS.
6. TIGHTEN 5/8" TORQUE TUBE CLAMP NUTS TO TORQUE OF 125-150FT.LBS.
7. TIGHTEN EQUALIZER SHAFT NUTS TO TORQUE OF 300FT.LBS. MAX. MAINTAIN 1/32" CLEARANCE BETWEEN WASHER AND CASTING.
8. SEE DRAWING 63200 FOR AXLE SEAT WELDING SPECS.
9. ESTIMATED WEIGHT 820 LBS. AS SHOWN WITH T 3564 SPRINGS, 3/4" HIGH SEAT, AND 5" RD. AXLE.
10. INSTALL SPRINGS WITH HOOKS TO REAR.

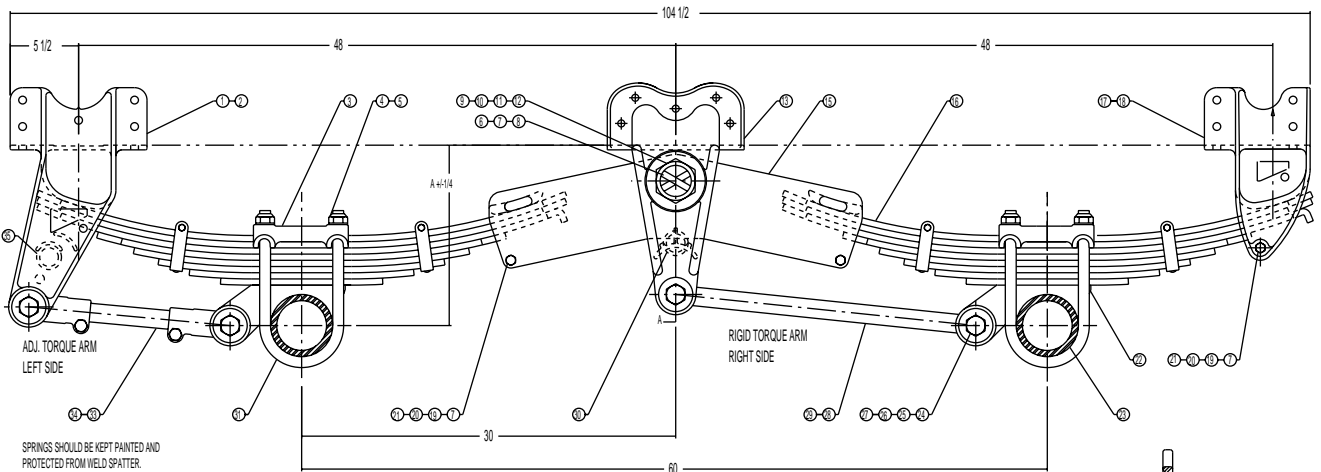
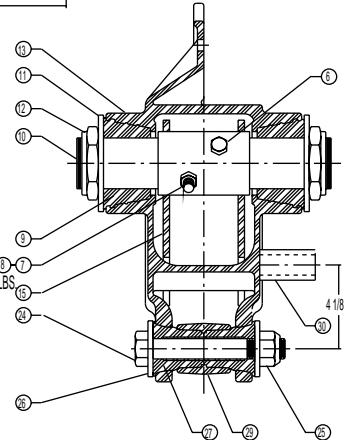

SPRINGS SHOULD BE KEPT PAINTED AND PROTECTED FROM WELD SPATTER. DO NOT ATTACH WELDING GROUND TO SPRINGS.

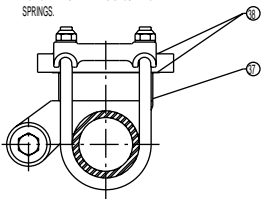

TYP. INSTALLATION SINGLE LEAF SPRING

SPRING LINERS MUST BE INSTALLED TOP AND BOTTOM OF SINGLE LEAF SPRINGS.

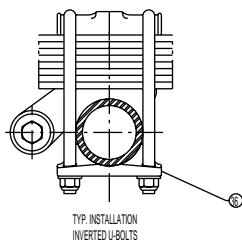

TYP. INSTALLATION INVERTED U-BOLTS

NOM. MTG. HT. "A"	SEAT HT.	SPRING CAMBER
13	3/4	LOW
14	3/4	MED.
14	2 3/4	MED. (S.L.)

NOTES:

1. "A" DIM. IS FROM BOTTOM OF FRAME TO - OF 5" DIA. AXLE WITH NO LOAD ON TANDEM.
2. MOUNT HANGER BRACKETS PARALLEL TO GROUND FOR EQUAL LOAD DISTRIBUTION.
3. HANGER BRACKET SPACING SHOULD BE HELD WITHIN TOLERANCE OF $\pm 1/16"$.
4. TIGHTEN U-BOLT NUTS TO TORQUE OF 300 FT.LBS.
5. TIGHTEN TORQUE ARM BOLT NUTS TO TORQUE OF 140-160 FT.LBS.
6. TIGHTEN 5/8" TORQUE ARM TUBE CLAMP NUTS TO TORQUE OF 125-150 FT.LBS.
7. SEE DRAWING 63200 FOR AXLE SEAT WELD SPECIFICATIONS
8. ESTIMATED WEIGHT 828 LBS. WITH T 3564 SPRINGS, 3/4" U-BOLTS AND 5" ROUND AXLES.
9. TIGHTEN EQUALIZER SHAFT NUTS TO TORQUE OF 300 FT.LBS. MAX. TORQUE.
10. INSTALL SPRINGS WITH HOOKS TO REAR.

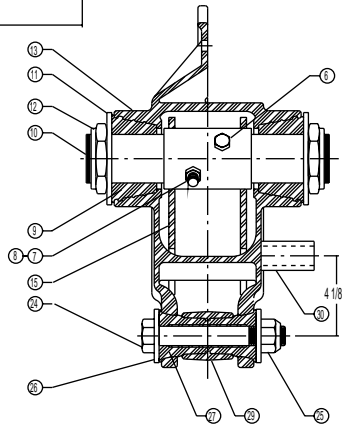

Maintenance Instructions Model 21B

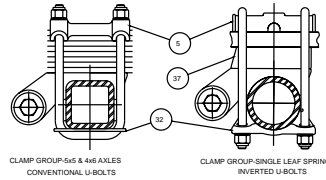
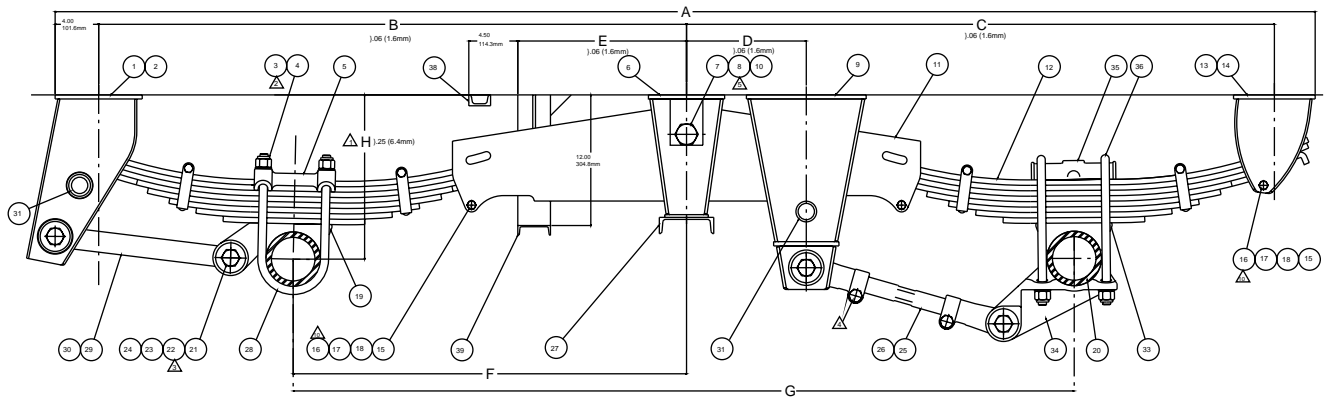

	2769mm	3880mm	1842mm	1842mm	749mm	864mm	1384mm	2769mm
	109	152.75	72.50	72.50	29.50	34.00	54.50	109.00
	2464mm	3575mm	1689mm	1689mm	597mm	711mm	1232mm	2464mm
	97	140.75	66.50	66.50	23.50	28.00	48.50	97.00
	1829mm	2940mm	1372mm	1372mm	279mm	394mm	914mm	1829mm
	72	115.75	54.00	54.00	11.00	15.50	36.00	72.00
AXLE	A	B	C	D	E	F NOM.	G NOM.	
SPACING	DIMENSION							

NOTES:

- SEE BILL OF MATERIAL FOR MOUNTING HEIGHT "H".
- TIGHTEN U-BOLT NUTS TO 300-325 FT-LB (410-440 Nm) TORQUE.
- TIGHTEN TORQUE ARM BOLT NUTS TO 160-200 FT-LB (215-270 Nm).
- TIGHTEN 5/8" TORQUE ARM CLAMP NUTS TO 125-150 FT-LB (170-200 Nm).
- TIGHTEN EQUALIZER SHAFT NUT TO 575-625 FT-LB (780-850 Nm).
- INSTALL REVCO SPRINGS WITH HOOKS TO REAR.
- INSTALL SPRING LINER ON TOP & BOTTOM OF SINGLE-LEAF SPRING, ON TOP ONLY OF THREE-LEAF SPRING.
- INSTALL RIGID TORQUE ARMS ON CURB SIDE OF SUSPENSION.
- INSTALL HANGERS PARALLEL TO GROUND FOR EQUAL WEIGHT DISTRIBUTION.
- TIGHTEN SPRING RETAINER BOLT NUTS TO 60-80 FT-LB (80-110 Nm).

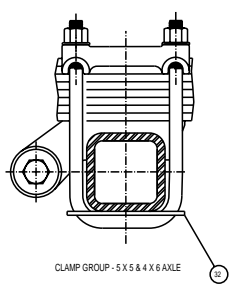
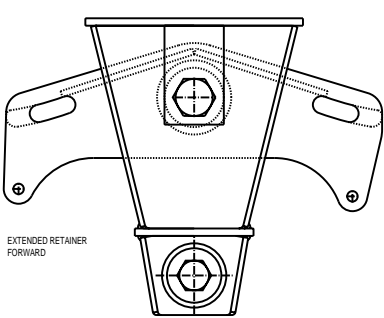
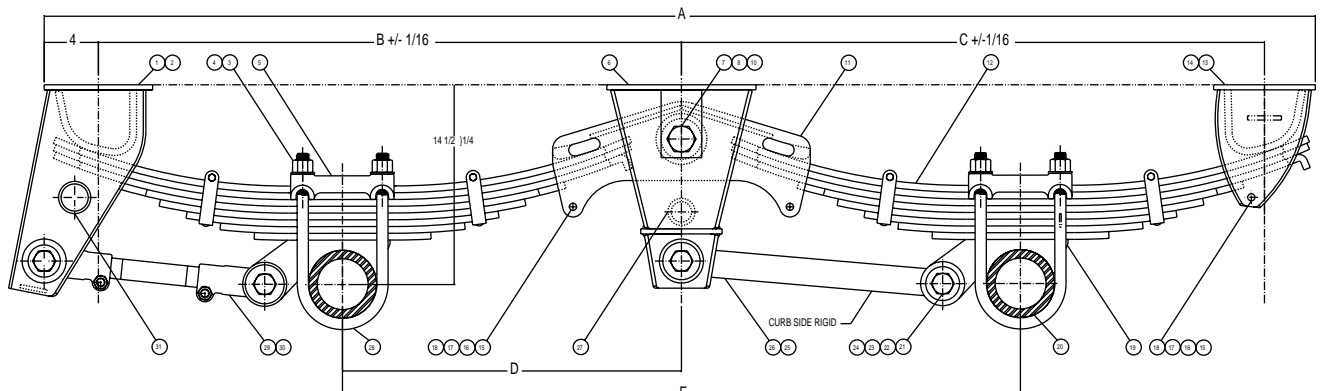

(1118)	(2102)	(953)	(953)	(567)	(1122)
44	82 3/4	37 1/2	37 1/2	22 5/16	44 3/16
(1651)	(2769)	(1286)	(1286)	(829)	(1664)
65	109	50 5/8	50 5/8	32 5/8	65 1/2
(1600)	(2724)	(1264)	(1264)	(810)	(1616)
63	107 1/4	49 3/4	49 3/4	31 7/8	63 5/8
(1524)	(2635)	(1219)	(1219)	(762)	(1524)
60	103 3/4	48	48	30	60
(1372)	(2502)	(1149)	(1149)	(694)	(1384)
54	98 1/2	45 1/4	45 1/4	27 5/16	54 1/2
(1270)	(2381)	(1092)	(1092)	(635)	(1270)
50	93 3/4	43	43	*25	*50
AXLE	A	B	C	D	E
SPACING	DIMENSION				

NOTES:

- MOUNTING HEIGHT DIMENSION IS FOR MEDIUM ARCH SPRINGS. 5" ROUND AXLE 3/4" HIGH SEAT, & UNLADEN TANDEM.
- MOUNT HANGERS PARALLEL TO GROUND FOR EQUAL WEIGHT DISTRIBUTION.
- TIGHTEN U-BOLT NUTS TO 300 LB.-FT. (410 N-m) TORQUE.
- TIGHTEN TORQUE ARM BOLT NUTS TO 140-160 LB.-FT.
- TIGHTEN TORQUE ARM CLAMP NUTS TO 80 LB.-FT. (110 N-m) (FOR FABRICATED TORQUE ARM ENDS)
- TIGHTEN EQUALIZER SHAFT NUT TO 575-625 LB.-FT. (780-850 N-m)
- INSTALL SPRINGS WITH HOOKS TO REAR.
- DIMENSIONS ARE IN INCHES & MILLIMETERS.
- FOR 50" AX. SPCG. WITH T-7452 SPRING USING T-7633 RIGID FRONT TORQUE ARM: DIM. D IS 25 1/2; DIM. E IS 50 1/2.
- TIGHTEN NUTS ON CAST ADJUSTABLE TORQUE ARM ENDS TO 125-150 LB.-FT.

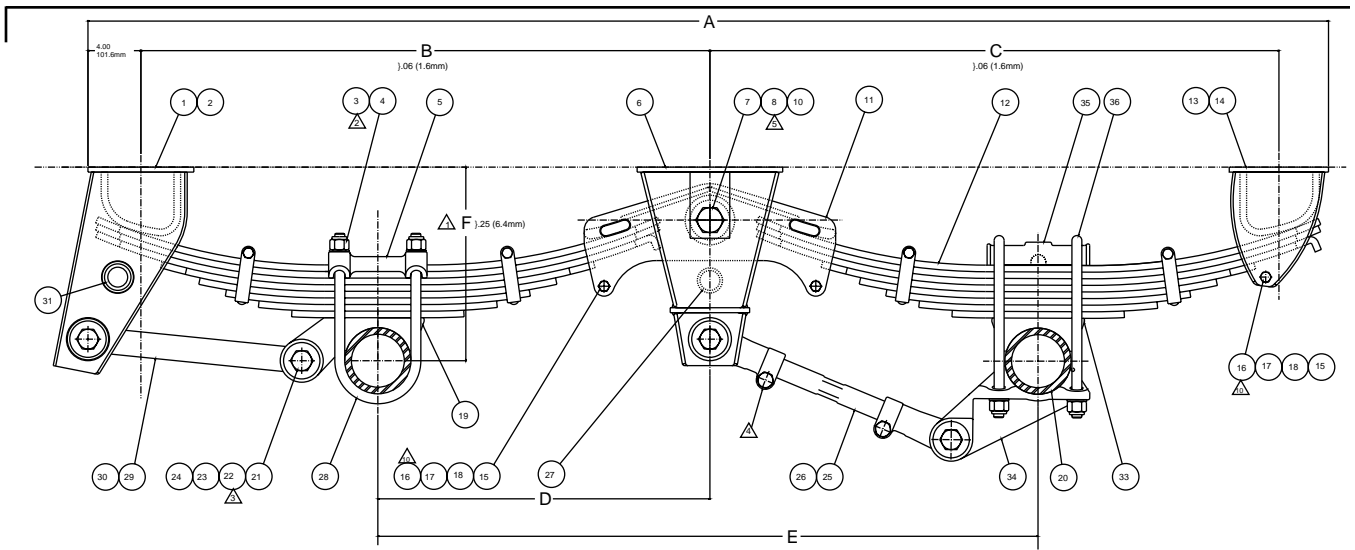
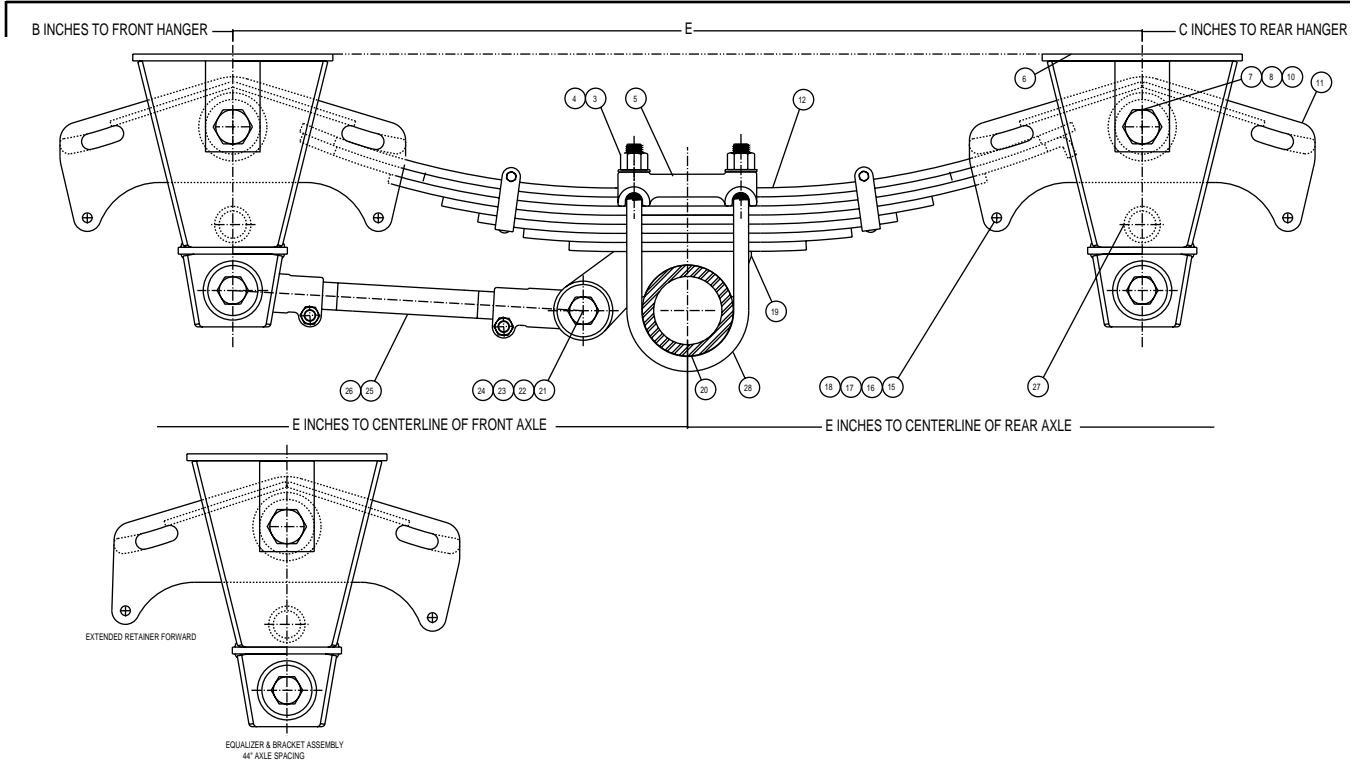

NOTES:

1. SEE BILL OF MATERIAL FOR MOUNTING HEIGHT "F".
2. TIGHTEN U-BOLT NUTS TO 300-325 FT-LB (410-440 Nm) TORQUE.
3. TIGHTEN TORQUE ARM BOLT NUTS TO 160-200 FT-LB (270-340 Nm).
4. TIGHTEN 5/8" TORQUE ARM CLAMP NUTS TO 125-150 FT-LB (170-200 Nm).
5. TIGHTEN EQUALIZER SHAFT NUT TO 575-625 FT-LB (780-850 Nm).
6. INSTALL REYCO SPRINGS WITH HOOKS TO REAR.
7. INSTALL SPRING LINER ON TOP & BOTTOM OF SINGLE-LEAF SPRING, ON TOP ONLY OF THREE-LEAF SPRING.
8. INSTALL RIGID TORQUE ARMS ON CURB SIDE OF SUSPENSION.
9. INSTALL HANGERS PARALLEL TO GROUND FOR EQUAL WEIGHT DISTRIBUTION.
10. TIGHTEN SPRING RETAINER BOLT NUTS TO 60-80 FT-LB (80-110 Nm).

	65	109.00	50.63	50.63	32.63	65.50
	1651mm	2769mm	1286mm	1286mm	829mm	1664mm
	63	107.25	49.75	49.75	31.88	63.63
	1600mm	2724mm	1264mm	1264mm	810mm	1616mm
(A)	60	103.75	48.00	48.00	30.00	60.00
	1524mm	2635mm	1219mm	1219mm	762mm	1524mm
	54	98.50	45.25	45.25	27.31	54.50
	1372mm	2502mm	1149mm	1149mm	694mm	1384mm
	50	93.75	43.00	43.00	25.00	50.00
	1270mm	2381mm	1092mm	1092mm	635MM	1270mm
AXLE A		B	C	D	NOM. E	NOM.
SPACING		DIMENSION				

Maintenance Instructions Model 21B

Drawing - 73129-2 & 74021

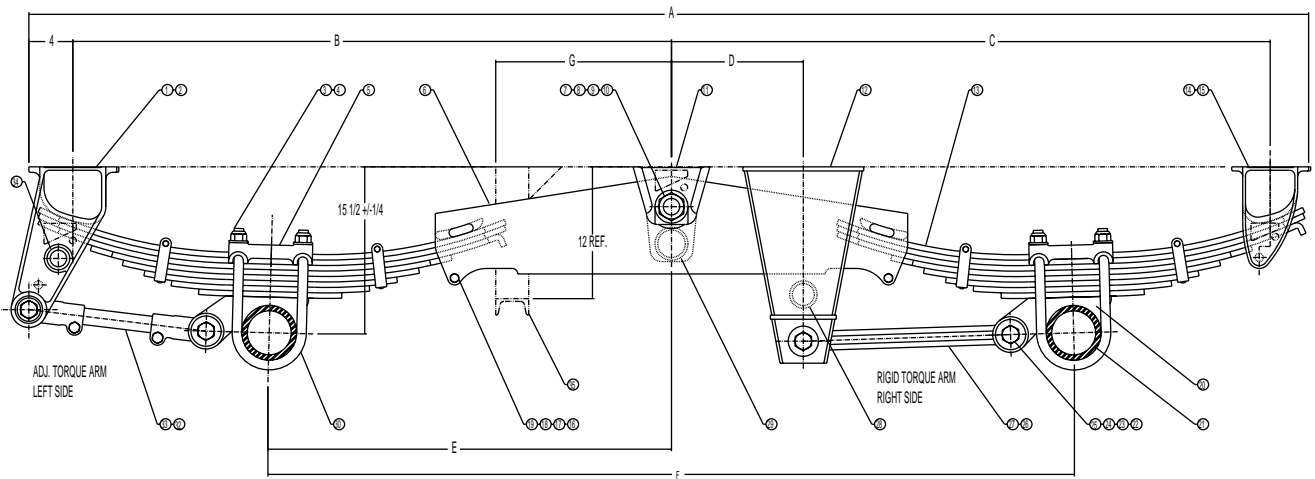

AXLE SPACING	DIMENSION TABLE						
	A	B	C	D	E	F	G
6'-1"	116 1/2	54 1/2	54 1/2	12	36 1/2	73	16
	2959mm	1384mm	1384mm	305mm	927mm	1854mm	406mm
8'-1"	140 1/2	66 1/2	66 1/2	24	48 1/2	97	28
	3569mm	1689mm	1689mm	610mm	1232mm	2464mm	711mm
9'-1"	152 1/2	72 1/2	72 1/2	30	54 1/2	109	34
	3874mm	1842mm	1842mm	762mm	1384mm	2769mm	864mm
10'-1"	164 1/2	78 1/2	78 1/2	36	60 1/2	121	40
	4178mm	1994mm	1994mm	914mm	1537mm	3073mm	1016mm
6'-0"	115 1/2	54	54	11 1/2	36	72	15 1/2
	2934mm	1372mm	1372mm	292mm	914mm	1829mm	394mm

- NOTES:
1. MTG. HT. DIMENSION SHOWN IS WITH MED. ARCH SPRINGS, 5" ROUND AXLES AND NO LOAD ON TANDEM.
 2. HANGER SPACING SHOULD BE HELD TO TOLERANCE OF +/-1/16".
 3. MOUNT HANGERS PARALLEL TO GROUND FOR EQUAL LOAD DISTRIBUTION.
 4. TIGHTEN TORQUE ARM BOLT NUTS TO 140-160 FT.LBS.
 5. TIGHTEN 5/8" TORQUE ARM TUBE CLAMP NUTS TO 125-150 FT.LBS.
 6. TIGHTEN U-BOLT NUTS TO 300 FT.LBS.
 7. TIGHTEN EQUALIZER SHAFT NUTS TO 200 FT.LBS.
 8. REINFORCEMENT BRIDGING BETWEEN HANGER BRACE PIPES AND FRAME CROSSMEMBERS IS RECOMMENDED.
 9. DIMENSIONS ARE SHOWN IN INCHES AND MILLIMETERS.
 10. MAKE EQUALIZER BRACE (ITEM 35) FROM 3" CHANNEL.
 11. SPRINGS SHOULD BE INSTALLED WITH HOOKS TO REAR.

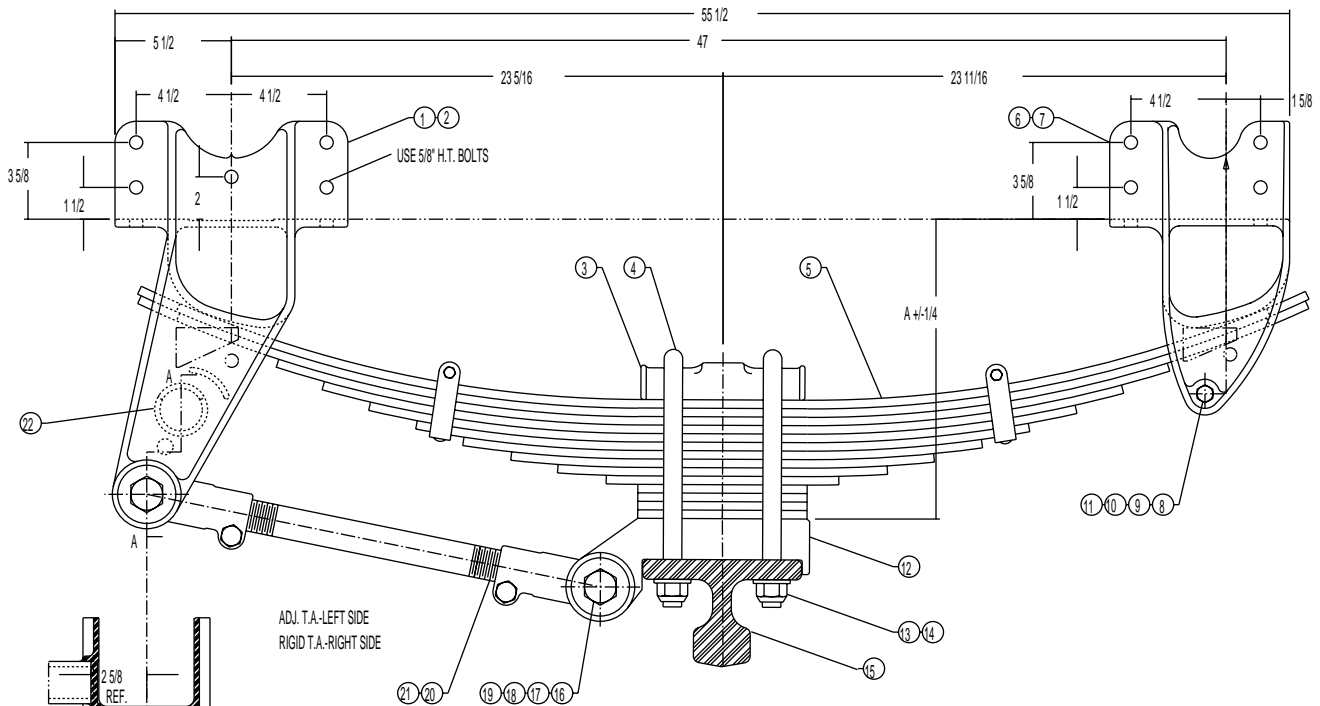

20000	18677 01	14 1/2	516
14600	18676 02	13	444
14600	18676 01	14	462
12000 TO 13200	18675 02	12 1/2	406
12000 TO 13200	18675 01	14	430
AXLE CAPACITY	SPRING NO.	A DIM.	ASSY. WT.

- NOTES:
1. MOUNTING HEIGHT (A DIM.) IS UNLADEN.
 2. INSTALL HANGERS TO TOLERANCE OF +/-1/16".
 3. TIGHTEN U-BOLT NUTS TO TORQUE OF 300 FT.LBS.
 4. TIGHTEN TORQUE ARM BOLT NUTS TO 140-160 FT.LBS.
 5. TIGHTEN 5/8" TORQUE ARM TUBE CLAMP NUTS TO TORQUE OF 125-150 FT.LBS.

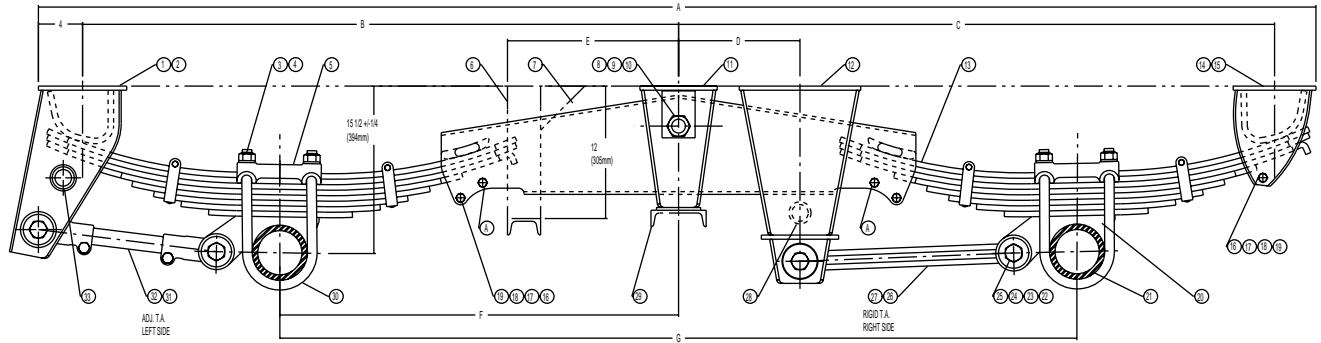

109" (2769mm)	152 3/4" (3880mm)	72 1/2" (1842mm)	72 1/2" (1842mm)	29 1/2" (749mm)	34" (864mm)	54 1/2" (1384mm)	109" (2769mm)
97" (2468mm)	140 3/4" (3575mm)	66 1/2" (1689mm)	66 1/2" (1689mm)	23 1/2" (597mm)	28" (711mm)	48 1/2" (1232mm)	97" (2464mm)
73" (1854mm)	116 3/4" (2966mm)	54 1/2" (1384mm)	54 1/2" (1384mm)	11 1/2" (292mm)	16" (406mm)	36 1/2" (927mm)	73" (1854mm)
72" (1829mm)	115 3/4" (2940mm)	54" (1372mm)	54" (1372mm)	11" (279mm)	15 1/2" (394mm)	36" (914mm)	72" (1829mm)
AXLE SPACING	A	B	C	D	E	F	G

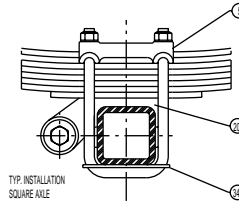

NOTES:

1. MOUNTING HEIGHT, 15 1/2" DIM. IS WITH 5" RD. AXLE, MEDIUM ARCH SPRINGS AND NO LOAD ON TANDEM.
2. MOUNT HANGERS PARALLEL TO GROUND FOR EQUAL LOAD DISTRIBUTION. HOLD SPACING TO TOLERANCE OF +/-1/16".
3. TIGHTEN TORQUE ARM BOLT NUTS TO TORQUE OF 140-160 FT.LBS.
4. TIGHTEN U-BOLT NUTS TO TORQUE 300-325 FT.LBS.
5. TIGHTEN TORQUE ARM TUBE CLAMP NUTS TO TORQUE OF 125-150 FT.LBS.
6. TIGHTEN EQUALIZER SHAFT NUT TO TORQUE OF 575-625 FT.LBS.
7. REINFORCEMENT BRIDGING BETWEEN HANGER CROSS-BRACES AND FRAME IS RECOMMENDED.
8. USE THIS SET OF EQUALIZER BOLT HOLES (A) FOR 72" AXLE SPACING ONLY.
9. MAKE EQUALIZER BRACE (ITEM 6) FROM 3" CHANNEL. MAKE CENTER HANGER BRACE (ITEM 23) FROM 5" CHANNEL.
10. DIMENSIONS SHOWN IN INCHES AND MILLIMETERS.

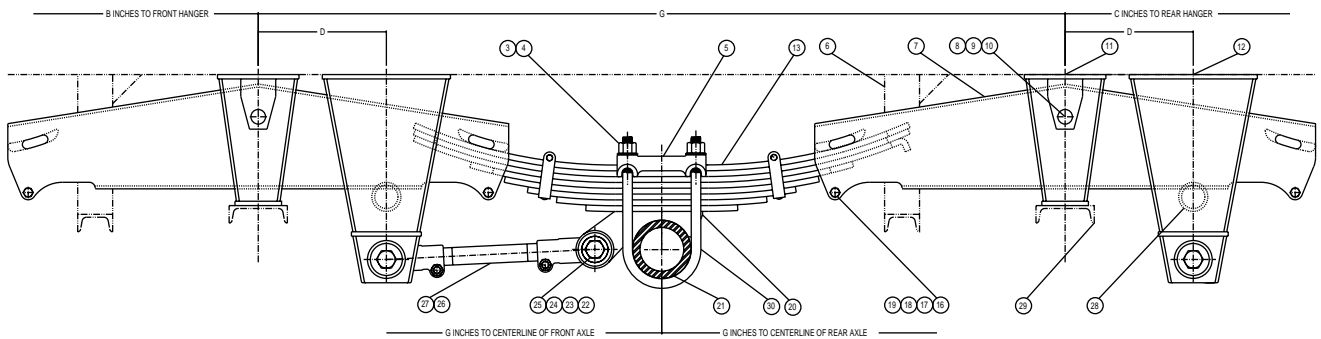

The Road To Success Is QVA...

Reyco
Granning
S U S P E N S I O N S

MISSOURI

Mount Vernon
1205 Industrial Park Drive
Mount Vernon, MO 65712
(800) 753-0050, Fax (417) 466-3964

www.reycogranning.com

Certified to the ISO 9001 Standard

Form #21BIM rev 0511

QVA

Quality: Providing worry-free reliability
Value: Exceeding customer expectations
Availability: Delivering on our promise, on time, every time