

\$25.00

MERITOR[®]
an **ArvinMeritor** brand

Maintenance Manual 1

Preventive Maintenance and Lubrication

Revised 07-10

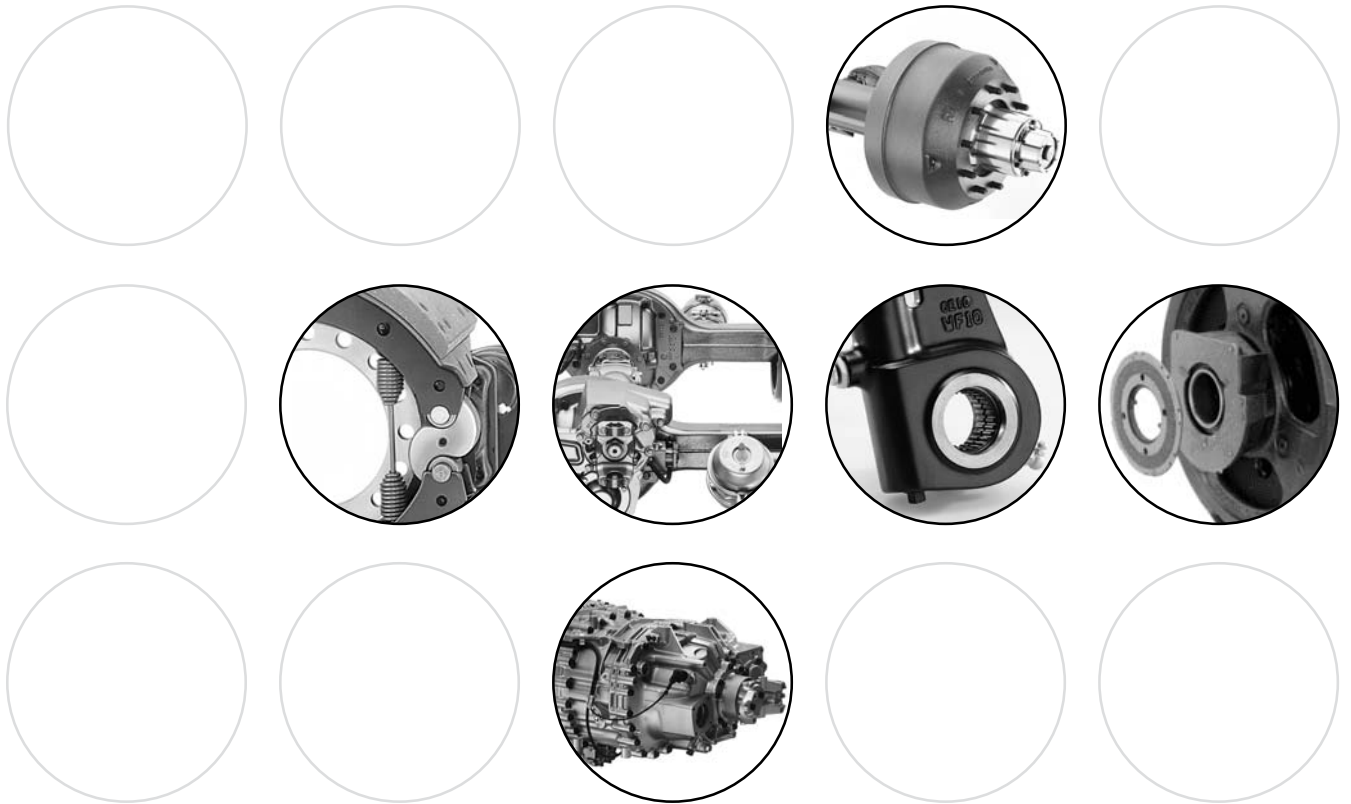

Service Notes

About This Manual

This manual provides maintenance intervals and procedures, lubricant specifications, and product capacities for Meritor components.

Before You Begin

1. Read and understand all instructions and procedures before you begin to service components.
2. Read and observe all Warning and Caution hazard alert messages in this publication. They provide information that can help prevent serious personal injury, damage to components, or both.
3. Follow your company's maintenance and service, installation, and diagnostics guidelines.
4. Use special tools when required to help avoid serious personal injury and damage to components.

Hazard Alert Messages and Torque Symbols

WARNING

A Warning alerts you to an instruction or procedure that you must follow exactly to avoid serious personal injury and damage to components.

CAUTION

A Caution alerts you to an instruction or procedure that you must follow exactly to avoid damage to components.

 This symbol alerts you to tighten fasteners to a specified torque value.

How to Obtain Additional Maintenance and Service Information

On the Web

Visit Literature on Demand at arvinmeritor.com to access and order product, service, aftermarket, and warranty literature for ArvinMeritor's truck, trailer and specialty vehicle components.

Literature on Demand (LODonDVD)

The LODonDVD contains product, service and warranty information for ArvinMeritor components. To order the DVD, visit Literature on Demand at arvinmeritor.com and specify TP-0742.

How to Obtain Tools and Supplies Specified in This Manual

Call ArvinMeritor's Commercial Vehicle Aftermarket at 888-725-9355 to obtain Meritor tools and supplies.

Information contained in this publication was in effect at the time the publication was approved for printing and is subject to change without notice or liability. Meritor Heavy Vehicle Systems, LLC, reserves the right to revise the information presented or to discontinue the production of parts described at any time.

| | | | |
|-----------|--|-----------|--|
| pg. i | Asbestos and Non-Asbestos Fibers | pg. 29 | Release Bearing |
| 1 | Section 1: Introduction | 30 | Clutch Housing |
| | Overview | | Linkage |
| | Regularly-Scheduled Maintenance | | Lubrication Intervals and Specifications |
| | Oil Lubricants | 31 | Troubleshooting |
| | Viscosity | 34 | Special Tools |
| | Oil Change Schedules | 35 | Section 4: Drivelines |
| | Oil Drain Conditions | | Technical Publications |
| 2 | National Lubricating Grease Institute (NLGI) Standards | | How to Obtain Additional Maintenance and Service Information |
| | Extreme Pressure (EP) Lubricants | | Description |
| 4 | Section 2: Bus and Coach | | RPL Series Permalube™ (Non-Greaseable) |
| | Technical Publications | | Wing-Style Permalube™ |
| | How to Obtain Additional Maintenance and Service Information | | Full-Round, Easy Service™, Wing-Style and 155R Series (Greaseable) |
| | Description | 36 | Identification |
| | Front Axles | | Inspection |
| 5 | Rear Axles | | Driveline |
| | Center Axles | 37 | End Yokes |
| | Important Information | 38 | Universal Joints |
| | Cam Brakes | | Center Bearings |
| 8 | Important Information | 39 | Slip Yoke |
| | Stopmaster® Wedge Brakes | 40 | Universal Joint Capscrews |
| | DiscPlus™ Brakes | 41 | Lubrication |
| 9 | T Series Parking Brake | | Xtended Lube MXL™ 17N, 176N and 18N Series Drivelines (Full Round) |
| | Identification | | Universal Joint |
| | Model Nomenclature | | Slip Yoke Splines |
| 12 | Inspection | 42 | RPL Series Permalube™ Driveline Universal Joint, Slip Yoke and Splines |
| | Front Axles | | Standard/Conventional Driveline Universal Joint |
| 13 | Lubrication | | Standard/Conventional Driveline Slip Yoke and Splines |
| | King Pin Bushings | | Wing-Style Permalube™ Driveline Universal Joint |
| 14 | Tie Rod | 43 | Wing-Style Greaseable Driveline Universal Joint |
| | Grease-Lubricated Wheel Bearings | | Wing-Style Permalube™ and Greaseable Driveline Slip Yoke and Splines |
| | Oil-Lubricated Wheel Bearings | 44 | Intervals |
| | Rear Axles | | Inspection and Maintenance |
| 15 | Inverted Portal Drive Axle | 46 | Lubrication Intervals and Specifications |
| 16 | Planetary Drive Axles | 47 | Lubrication Intervals for Xtended Lube MXL™ Series Drivelines |
| 17 | Cam Brakes | 48 | Troubleshooting |
| 18 | T Series Parking Brake | 51 | Section 5: Front Drive Steer Axles |
| 19 | Stopmaster® Brakes | | Technical Publications |
| 20 | Lubrication Intervals and Specifications | | How to Obtain Additional Maintenance and Service Information |
| 24 | Stopmaster® Wedge Brakes | | Description |
| 25 | Section 3: Clutches | | Front Drive Steer Axles |
| | Technical Publications | 52 | Identification |
| | How to Obtain Additional Maintenance and Service Information | | Model Nomenclature |
| | Description | | Front Drive Steer Axles |
| 26 | Identification | 54 | Front Drive Steer Axles, Prior Models |
| | Model Nomenclature | 56 | Inspection |
| 27 | Inspection | | Steering-Related Components |
| | When to Inspect the Clutch | | |
| | Clutch Linkage | | |
| 28 | Internal Parts of the Clutch | | |
| 29 | Lubrication | | |

Contents

| | | | |
|-----------|--|--------|--|
| pg. 56 | Steering Knuckle Vertical End Play Upper and Lower Knuckle Bushings | pg. 92 | Model Nomenclature |
| 57 | Tie Rod Ends | 93 | Important Information Cam Brake Inspection Intervals and Procedures On-Highway Linehaul Applications Off-Highway Linehaul Applications Q Plus™ LX500 and MX500 Cam Brakes with Automatic Slack Adjusters Do Not Lubricate the LX500 and MX500 Brakes and Automatic Slack Adjuster Before the Specified Time or Mileage Intervals Inspection Procedure |
| 58 | Servicing the Tie Rod Ends Why It's Important to Inspect the Tie Rod Ends for Wear and Allowable Movement at the Regularly-Scheduled Intervals | 94 | Cam Brakes, All Models |
| 59 | Tie Rod Assembly Movement | 95 | Important Information Commercial Vehicle Safety Alliance (CVSA) Guidelines |
| 61 | Steering Arm Bolts Sealed Hub Units Carrier | 96 | Cam Brake Lubrication Intervals and Procedures |
| 62 | Check and Adjust the Oil Level Drain and Replace the Oil Lubrication King Pin Bushings | 98 | Q Plus™ LX500 and MX500 Cam Brakes and Automatic Slack Adjusters After the Specified Time or Mileage Intervals Cam Brake Tips |
| 63 | Camshaft Retainer Bushing and Cam Bushing Cross Tube End Assembly | 99 | Approved Lubricants |
| 64 | Drive Axle Shaft Universal Joints Axle Shaft Spline and Thrust Washer Knuckle Bushing Wheel Bearings | 101 | Important Information Cam Brake Troubleshooting Diagnostic Charts |
| 65 | Tie Rod End | 102 | Air Disc Brakes Technical Publications Description Features |
| 66 | Steering Knuckle Sockets Lubrication Intervals and Specifications | 103 | Identification |
| 68 | Troubleshooting | 104 | Air Disc Brake Inspection Intervals and Procedures Inspection Schedules |
| 70 | Section 6: Front Non-Drive Steer Axles How to Obtain Additional Maintenance and Service Information Description | 105 | Important Information Commercial Vehicle Safety Alliance (CVSA) Guidelines |
| 71 | Identification Model Nomenclature | 106 | Important Information Checking the Adjusted Chamber Stroke Length on DiscPlus™ DX195 and DX225 Air Disc Brakes |
| 72 | Inspection Parts | 107 | DiscPlus™ DX195 and DX225 Air Disc Brake Components |
| 73 | Steering Knuckle Vertical End Play | 108 | Air Disc Brake Model ADB 1560 Lubrication Intervals and Procedures Lubrication Procedures |
| 75 | Upper and Lower King Pin Bushings | 109 | Approved Lubricants |
| 76 | Unitized Wheel End | 110 | Important Information Air Disc Brake Troubleshooting Brake Diagnostic Charts |
| 77 | Tie Rod and Cross Tube Assembly | 113 | Important Information DiscPlus™ DX195 and DX225 Air Disc Brakes |
| 80 | Department of Transportation Roadside Tie Rod Assembly Replacement Criteria Lubrication Tie Rod End | 114 | Automatic Slack Adjusters Important Information Technical Publications Intervals |
| 81 | King Pin Bushings | 115 | Identification Procedures At Brake Reline |
| 82 | Ball Studs on the Steering Arm and the Tie Rod Arm Ends | 116 | Approved Lubricants Anti-Seize Compound |
| 83 | Grease-Lubricated Wheel Bearings Oil-Lubricated Wheel Bearings | 117 | Important Information Automatic Slack Adjuster Troubleshooting |
| 84 | Check and Adjust Steering Arm Bolts Tighten Draw Key Nuts | | |
| 85 | Lubrication Intervals and Specifications | | |
| 88 | Lubricant Troubleshooting | | |
| 90 | Section 7: Brakes Cam Brakes Technical Publications Description | | |
| 91 | Identification | | |

| | | | |
|--|--|---------------------------------------|---|
| pg. 117 | Diagnostic Charts | pg. 148 | Advanced Lube Axles |
| 118 | Wedge Brakes | | R-170 Axles Equipped with Traction Equalizer® |
| | Technical Publications | | Limited Slip Friction Modifiers |
| | Description | 149 | Fill Plug Locations |
| | Identification | 150 | Check and Adjust the Oil Level |
| 119 | Important Information | | Drain and Replace the Oil |
| | Brake Adjustment Procedure | | Inter-Axle Assemblies with Separate Housings |
| | Inspection Procedure | 151 | Lubrication Intervals and Specifications |
| 120 | Lubrication | | Lubrication Analysis Recommendations |
| 121 | Approved Lubricants | 155 | Troubleshooting |
| | Important Information | | All Rear Axles |
| | Wedge Brake Troubleshooting | 156 Section 9: Suspensions | |
| | Diagnostic Charts | | Technical Publications |
| 124 | Four-Piston Quadraulic Disc Brakes | | How to Obtain Additional Maintenance and Service Information |
| | Technical Publications | | RideStar™ RHP Series Trailer Air Suspension Systems |
| | Description | | Single-Axle System |
| | Identification | 157 | Sliding Tandem System |
| 125 | Four-Piston Quadraulic Disc Brake Inspection | 158 | Inspection |
| | Bleeding the Brake System | | Single-Axle and Sliding Tandem Suspensions |
| 126 | Four-Piston Quadraulic Disc Brake Troubleshooting | 159 | Maintenance |
| | Diagnostic Charts | | Single-Axle and Sliding Tandem Suspensions |
| 128 | DuraPark® Hydraulic Drum Brakes | 160 | Upper Control Arm Bushing Periodic Inspection Guidelines: |
| | Technical Publications | | All RideStar™ |
| | Description | | RHP Series Trailer Air Suspension Systems |
| | DuraPark® Hydraulic Brake Product Update | 161 | Slider on Sliding Tandem Suspension System |
| 129 | Adjustment Procedures | 162 | RideStar™ RFS Series Trailer Air Suspension System |
| 130 | Brake Drums and Rotors | | Ride Height |
| | Technical Publications | 164 | Tire Clearance |
| | Brake Drum Inspection and Failure Analysis | | Maintenance |
| 131 | Brake Drum Wear Inspection | 166 | Inspect the Shock Absorbers |
| | Clean the Mounting Surfaces | 169 Section 10: Trailer Axles | |
| 132 | Brake Drum Procedures | | Important Information |
| 133 | Brake Drum Wear Conditions | | Technical Publications |
| 137 | Conditions That Can Affect Brake Drum Wear | | How to Obtain Additional Maintenance and Service Information |
| 138 | Brake Drum Diagnostics | | Description |
| 140 | Rotors | | Axle Models |
| | Rotor Wear Inspection | | Axle Designs |
| | Measuring the Thickness of the Rotor or Disc | 170 | TB Series Trailer Axles with Unitized Wheel-End Assemblies |
| 141 Section 8: Rear Drive Axles | | 171 | How to Identify Trailer Axles with Unitized Wheel Ends |
| | Technical Publications | | How to Find the Model Number, Serial Number and Date of Manufacture |
| | How to Obtain Additional Maintenance and Service Information | 172 | What the Numbers Mean |
| | Description | | Model Number |
| | Identification | | Serial Number |
| 143 | Model Nomenclature | | Date of Manufacture |
| | Axle Model Numbers and Designations | | Model Nomenclature |
| 145 | Inspection | | Current Production Model Numbers |
| | Carrier | 174 Section 11: Transfer Cases | |
| | Oil Seals | | Technical Publications |
| 146 | Seal Test Procedure | | How to Obtain Additional Maintenance and Service Information |
| | Example 1: The Seal is not Leaking | | Description |
| 147 | Example 2: The Seal Appears to be Leaking | | |
| | Example 3: The Seal is Leaking | | |
| 148 | Lubrication | | |

Contents

| | | | |
|--------------------------------------|--|--|--|
| pg. 174 | Identification | pg. 193 | Approved Oil |
| 175 | Model Nomenclature | 194 | Troubleshooting |
| 176 | Lubricant Temperatures | | On Manual Transmissions |
| | Meritor MTC-4208, MTC-4209 and MTC-4210 Series | | Oil Leaks |
| | Transfer Cases | | On New Transmissions |
| | Other Meritor Transfer Cases | | Vibration |
| | Do Not Install API GL-5 Oils | 195 | Noise |
| | Inspection | | Operation Problems |
| | Magnets and Magnetic Drain Plugs | | Troubleshooting Leaks |
| 177 | Operating Information | 196 | Troubleshooting Vibrations |
| | Breather | 197 | Troubleshooting Noises |
| | Seals | 198 | Troubleshooting Operating Conditions |
| | Check and Adjust the Oil Level | | |
| 178 | Drain and Replace the Oil | 201 Section 13: Wheel Bearings and Wheel Ends | |
| | Transfer Case Oil | | Technical Publications |
| | Intervals | | How to Obtain Additional Maintenance and Service |
| | Towing Procedures | | Information |
| 179 | Specifications | | Conventional Wheel Ends |
| | Capacities | | Description |
| 180 | Troubleshooting | 202 | Model Nomenclature |
| 186 Section 12: Transmissions | | 204 | Oil-Lubricated Wheel Bearings |
| | Technical Publications | 207 | Grease-Lubricated Wheel Bearings |
| | How to Obtain Additional Maintenance and Service | 210 | Important Information |
| | Information | | Long-Life Wheel Ends |
| | Description | | Front Non-Drive Steer Axles with Unitized Hubs |
| 187 | Manual Transmissions | | Identification |
| | Engine Synchro Shift™ (ESS™) Transmission Shift System | 211 | Model Nomenclature |
| | SureShift™ Transmission | | Inspection Procedure |
| | ZF-FreedomLine Transmission | | Inspection Intervals |
| | Identification | | Tools Required |
| 188 | Model Nomenclature | 212 | Basic Inspection |
| 189 | Intervals | | Detailed Inspection |
| | Every 10,000 Miles (16 000 km) of Vehicle Operation | 214 | Replacement Hub Inspection |
| | Every 50,000 Miles (80 000 km) of Vehicle Operation | | Install the Spindle O-Rings and Hubcaps |
| | (Approved Petroleum Base and Heavy-Duty Engine Oils) | 215 | Unitized Wheel Ends on Bus and Coach FH Series Front and |
| | Every 500,000 Miles (400 000 km) of Vehicle Operation | | Tag Axles, and MC Series Rear Drive Axles |
| | (Approved Full-Synthetic Oils) | 216 | Inspection |
| 190 | Inspection | 219 | Disassemble the Unitized Wheel End |
| | Oil Drain Conditions | 221 | Trailer Axles with Long-Life Wheel Ends |
| | Magnets and Magnetic Drain Plugs | 222 | Model Nomenclature |
| | Transmission Oil Coolers | 223 | TB Series Trailer Axles with Unitized Hub Assemblies |
| | Temperature Indicator | 224 | TL Series Trailer Axles with Packaged Bearing Hub |
| | Check and Adjust the Oil Level | | Assemblies |
| 191 | Inspection | 226 | Trailer Lubrication Intervals and Specifications |
| | Breather Vent Condition | | TRIAD™ Trailer Axle Wheel-End System |
| | Fastener Torque | | Wheel-End Equipment Checks |
| 192 | Inspecting the Transmission for Leaks and Damage | | Studs and Nuts |
| | Drain and Replace the Oil | 230 | Installing Double-Ended Metric Wheel Studs with 3/4-16 |
| | Transmission Oil | | and M22 x 1.5 Threads Onto Hub and Rotor Assemblies |
| | Adjustment | | on Axles Equipped with Meritor Air Disc Brake Model ADB |
| | Linkage for the Remote Control Assembly | | 1560 |
| 193 | Lubrication | 231 | Vehicles Equipped with ABS |
| | Remote Control Assembly | 232 Section 14: Specifications | |
| | ZF-FreedomLine Clutch Fork | | Lubrication Intervals and Specifications |
| | Lubrication Intervals and Specifications | | Grease Lubricants |
| | | 233 | Oil Lubricants |

ASBESTOS FIBERS WARNING

The following procedures for servicing brakes are recommended to reduce exposure to asbestos fiber dust, a cancer and lung disease hazard. Material Safety Data Sheets are available from ArvinMeritor.

Hazard Summary

Because some brake linings contain asbestos, workers who service brakes must understand the potential hazards of asbestos and precautions for reducing risks. Exposure to airborne asbestos dust can cause serious and possibly fatal diseases, including asbestosis (a chronic lung disease) and cancer, principally lung cancer and mesothelioma (a cancer of the lining of the chest or abdominal cavities). Some studies show that the risk of lung cancer among persons who smoke and who are exposed to asbestos is much greater than the risk for non-smokers. Symptoms of these diseases may not become apparent for 15, 20 or more years after the first exposure to asbestos.

Accordingly, workers must use caution to avoid creating and breathing dust when servicing brakes. Specific recommended work practices for reducing exposure to asbestos dust follow. Consult your employer for more details.

Recommended Work Practices

1. **Separate Work Areas.** Whenever feasible, service brakes in a separate area away from other operations to reduce risks to unprotected persons. OSHA has set a maximum allowable level of exposure for asbestos of 0.1 f/cc as an 8-hour time-weighted average and 1.0 f/cc averaged over a 30-minute period. Scientists disagree, however, to what extent adherence to the maximum allowable exposure levels will eliminate the risk of disease that can result from inhaling asbestos dust. OSHA requires that the following sign be posted at the entrance to areas where exposures exceed either of the maximum allowable levels:

DANGER: ASBESTOS
CANCER AND LUNG DISEASE HAZARD
AUTHORIZED PERSONNEL ONLY
RESPIRATORS AND PROTECTIVE CLOTHING
ARE REQUIRED IN THIS AREA.

2. **Respiratory Protection.** Wear a respirator equipped with a high-efficiency (HEP A) filter approved by NIOSH or MSHA for use with asbestos at all times when servicing brakes, beginning with the removal of the wheels.

3. **Procedures for Servicing Brakes.**

- a. Enclose the brake assembly within a negative pressure enclosure. The enclosure should be equipped with a HEPA vacuum and worker arm sleeves. With the enclosure in place, use the HEPA vacuum to loosen and vacuum residue from the brake parts.
- b. As an alternative procedure, use a catch basin with water and a biodegradable, non-phosphate, water-based detergent to wash the brake drum or rotor and other brake parts. The solution should be applied with low pressure to prevent dust from becoming airborne. Allow the solution to flow between the brake drum and the brake support or the brake rotor and caliper. The wheel hub and brake assembly components should be thoroughly wetted to suppress dust before the brake shoes or brake pads are removed. Wipe the brake parts clean with a cloth.
- c. If an enclosed vacuum system or brake washing equipment is not available, employers may adopt their own written procedures for servicing brakes, provided that the exposure levels associated with the employer's procedures do not exceed the levels associated with the enclosed vacuum system or brake washing equipment. Consult OSHA regulations for more details.
- d. Wear a respirator equipped with a HEPA filter approved by NIOSH or MSHA for use with asbestos when grinding or machining brake linings. In addition, do such work in an area with a local exhaust ventilation system equipped with a HEPA filter.
- e. **NEVER** use compressed air by itself, dry brushing, or a vacuum not equipped with a HEPA filter when cleaning brake parts or assemblies. **NEVER** use carcinogenic solvents, flammable solvents, or solvents that can damage brake components as wetting agents.

4. **Cleaning Work Areas.** Clean work areas with a vacuum equipped with a HEPA filter or by wet wiping. **NEVER** use compressed air or dry sweeping to clean work areas. When you empty vacuum cleaners and handle used rags, wear a respirator equipped with a HEPA filter approved by NIOSH or MSHA for use with asbestos. When you replace a HEPA filter, wet the filter with a fine mist of water and dispose of the used filter with care.

5. **Worker Clean-Up.** After servicing brakes, wash your hands before you eat, drink or smoke. Shower after work. Do not wear work clothes home. Use a vacuum equipped with a HEPA filter to vacuum work clothes after they are worn. Launder them separately. Do not shake or use compressed air to remove dust from work clothes.

6. **Waste Disposal.** Dispose of discarded linings, used rags, cloths and HEPA filters with care, such as in sealed plastic bags. Consult applicable EPA, state and local regulations on waste disposal.

Regulatory Guidance

References to OSHA, NIOSH, MSHA, and EPA, which are regulatory agencies in the United States, are made to provide further guidance to employers and workers employed within the United States. Employers and workers employed outside of the United States should consult the regulations that apply to them for further guidance.

NON-ASBESTOS FIBERS WARNING

The following procedures for servicing brakes are recommended to reduce exposure to non-asbestos fiber dust, a cancer and lung disease hazard. Material Safety Data Sheets are available from ArvinMeritor.

Hazard Summary

Most recently manufactured brake linings do not contain asbestos fibers. These brake linings may contain one or more of a variety of ingredients, including glass fibers, mineral wool, aramid fibers, ceramic fibers and silica that can present health risks if inhaled. Scientists disagree on the extent of the risks from exposure to these substances. Nonetheless, exposure to silica dust can cause silicosis, a non-cancerous lung disease. Silicosis gradually reduces lung capacity and efficiency and can result in serious breathing difficulty. Some scientists believe other types of non-asbestos fibers, when inhaled, can cause similar diseases of the lung. In addition, silica dust and ceramic fiber dust are known to the State of California to cause lung cancer. U.S. and international agencies have also determined that dust from mineral wool, ceramic fibers and silica are potential causes of cancer.

Accordingly, workers must use caution to avoid creating and breathing dust when servicing brakes. Specific recommended work practices for reducing exposure to non-asbestos dust follow. Consult your employer for more details.

Recommended Work Practices

1. **Separate Work Areas.** Whenever feasible, service brakes in a separate area away from other operations to reduce risks to unprotected persons.

2. **Respiratory Protection.** OSHA has set a maximum allowable level of exposure for silica of 0.1 mg/m³ as an 8-hour time-weighted average. Some manufacturers of non-asbestos brake linings recommend that exposures to other ingredients found in non-asbestos brake linings be kept below 1.0 f/cc as an 8-hour time-weighted average. Scientists disagree, however, to what extent adherence to these maximum allowable exposure levels will eliminate the risk of disease that can result from inhaling non-asbestos dust.

Therefore, wear respiratory protection at all times during brake servicing, beginning with the removal of the wheels. Wear a respirator equipped with a high-efficiency (HEP A) filter approved by NIOSH or MSHA, if the exposure levels may exceed OSHA or manufacturers' recommended maximum levels. Even when exposures are expected to be within the maximum allowable levels, wearing such a respirator at all times during brake servicing will help minimize exposure.

3. **Procedures for Servicing Brakes.**

- a. Enclose the brake assembly within a negative pressure enclosure. The enclosure should be equipped with a HEPA vacuum and worker arm sleeves. With the enclosure in place, use the HEPA vacuum to loosen and vacuum residue from the brake parts.
- b. As an alternative procedure, use a catch basin with water and a biodegradable, non-phosphate, water-based detergent to wash the brake drum or rotor and other brake parts. The solution should be applied with low pressure to prevent dust from becoming airborne. Allow the solution to flow between the brake drum and the brake support or the brake rotor and caliper. The wheel hub and brake assembly components should be thoroughly wetted to suppress dust before the brake shoes or brake pads are removed. Wipe the brake parts clean with a cloth.
- c. If an enclosed vacuum system or brake washing equipment is not available, carefully clean the brake parts in the open air. Wet the parts with a solution applied with a pump-spray bottle that creates a fine mist. Use a solution containing water, and, if available, a biodegradable, non-phosphate, water-based detergent. The wheel hub and brake assembly components should be thoroughly wetted to suppress dust before the brake shoes or brake pads are removed. Wipe the brake parts clean with a cloth.
- d. Wear a respirator equipped with a HEPA filter approved by NIOSH or MSHA when grinding or machining brake linings. In addition, do such work in an area with a local exhaust ventilation system equipped with a HEPA filter.
- e. **NEVER** use compressed air by itself, dry brushing, or a vacuum not equipped with a HEPA filter when cleaning brake parts or assemblies. **NEVER** use carcinogenic solvents, flammable solvents, or solvents that can damage brake components as wetting agents.

4. **Cleaning Work Areas.** Clean work areas with a vacuum equipped with a HEPA filter or by wet wiping. **NEVER** use compressed air or dry sweeping to clean work areas. When you empty vacuum cleaners and handle used rags, wear a respirator equipped with a HEPA filter approved by NIOSH or MSHA, to minimize exposure. When you replace a HEPA filter, wet the filter with a fine mist of water and dispose of the used filter with care.

5. **Worker Clean-Up.** After servicing brakes, wash your hands before you eat, drink or smoke. Shower after work. Do not wear work clothes home. Use a vacuum equipped with a HEPA filter to vacuum work clothes after they are worn. Launder them separately. Do not shake or use compressed air to remove dust from work clothes.

6. **Waste Disposal.** Dispose of discarded linings, used rags, cloths and HEPA filters with care, such as in sealed plastic bags. Consult applicable EPA, state and local regulations on waste disposal.

Regulatory Guidance

References to OSHA, NIOSH, MSHA, and EPA, which are regulatory agencies in the United States, are made to provide further guidance to employers and workers employed within the United States. Employers and workers employed outside of the United States should consult the regulations that apply to them for further guidance.

Overview

This manual provides maintenance and lubrication information for Meritor-produced components, including inspection and service intervals, procedures, grease and oil specifications and product capacities. Troubleshooting information is also provided to assist in diagnosing customer concerns. Following these guidelines will enable you to correctly lubricate and maintain components, and correct issues to help ensure maximum component life.

- Always follow recommended maintenance intervals and procedures.
- Always use the specified oil or grease lubricant from a manufacturer that provides quality products and complete application instructions.

To obtain additional maintenance and service information for components included in this manual, refer to the Service Notes page on the front inside cover of this manual.

Regularly-Scheduled Maintenance

Internal components can shed fine metal wear particles at a steady rate, especially during the break-in period. If wear particles, moisture and other contaminants are allowed to circulate in the lubricant, the components will wear at a faster rate than normal.

Regularly-scheduled maintenance using the specified lubricants will help to ensure maximum component performance and life.

Oil Lubricants

There are three types of oil lubricants: petroleum, full-synthetic and semi-synthetic. Both full-synthetic and semi-synthetic oils retain their lubrication properties longer than petroleum oil.

- Petroleum oil is derived from crude oil. Crude petroleum oil also yields combustible fuels and a wide range of petroleum chemicals.
- Full-synthetic oil uses a man-made-base oil with predictable physical properties. Full-synthetic oil contains no refined petroleum-base fluids.
- Semi-synthetic oil contains a mixture of petroleum-base and synthetic fluids that can help extend service intervals, improve cold weather properties and reduce volatility.

Viscosity

CAUTION

Use the correct viscosity lubricants. Do not lower the viscosity of lubricants by adding thinning agents, such as kerosene, gasoline or other dilutents. Damage to components will result.

Select the correct viscosity oil for a specific component from the tables in each section of this manual. When more than one lubricant is listed, choose an oil viscosity that is suitable for the expected outside temperature.

Oil viscosity grades and classifications are provided by the Society of Automotive Engineers (SAE) and the American Petroleum Institute (API).

- Use multigrade oils when vehicles operate in both cold and warm weather between oil changes.
- Use low viscosity single grade oils only in cold climates. Single grade 75W oils are not approved for use in drive axles where ambient or outside temperatures exceed 40°F (4°C).
- Use multigrade oil for drive axles only. The hypoid gearing requires a GL-5 oil with Extreme Pressure (EP) additives to provide adequate lubricant film protection that prevents gear failure.

Oil Change Schedules

To determine an oil change schedule, take an oil sample at a specified interval or mileage recommendation. Analyze the sample to establish a schedule.

However, service duty will often dictate when to change the oil, regardless of mileage or a previously-established schedule.

Oil Drain Conditions

Differential Oil (Hypoid Gear Oils)

Drain and replace used differential oil that does not meet the following used-oil analyses. Replace the drained oil with the oil specified for hypoid drive axle use.

Meritor recommends that you perform a lubricant analysis at every regularly-scheduled preventive maintenance interval.

1 Introduction

Table A: Used-Oil Analyses (ppm = parts per million)

| | |
|-------------------------------|--|
| Iron (Fe) | If the level is 1000-1500 ppm, resample the oil. If resampling indicates that the iron level is above 1000 ppm, drain and replace the oil. If the level is above 1500 ppm, drain and replace the oil. |
| Silicon (Si) | If the level is greater than 100 ppm, drain and replace the oil. |
| Water (H₂O) | If the level is greater than 0.3%, drain and replace the oil. |
| Phosphorus (P) | If the level is less than 900 ppm, it is possible that the oil is not a GL-5 gear oil. Contact the lubricant manufacturer or Meritor Materials Engineering to determine the expected phosphorus level of a new oil sample. Only GL-5 type gear oils are approved for use in Meritor differentials. |
| Toluene Insolubles | If the level is greater than 0.100 wt.%, drain and replace the oil. |

Manual Transmission Oils

If used transmission oil analyses indicate that any one of these criteria is not met, drain the used oil and replace it with an oil that is recommended for manual transmissions.

Table B: Used-Oil Analyses (ppm = parts per million)

| | |
|-------------------------------|--|
| Iron (Fe) | If the level is greater than 500 ppm, drain and replace the oil. |
| Silicon (Si) | If the level is greater than 100 ppm, drain and replace the oil. |
| Water (H₂O) | If the level is greater than 0.3%, drain and replace the oil. |

Grease Lubricants

Grease lubricants contain three substances: oil, thickener base and additives. The oil lubricates. The thickener or base holds the oil in place and releases it to provide the necessary lubrication. The thickener may be a simple or complex soap (lithium, calcium, aluminum, etc.), organic (polyurea) or inorganic (clay). The additives enhance the characteristics of the oil and thickener. Extreme Pressure (EP) additives help prevent scoring, galling and welding of moving parts.

Do not mix different types of grease. Incompatible greases may reduce the lubricating ability of the greases.

An important property of a grease is its dropping point, the temperature where grease changes from a semi-solid state to a liquid state. However, the operating temperature of a specific grease is not determined solely by the dropping point. Other properties such as resistance to change in consistency and chemical deterioration at high temperatures must be considered.

National Lubricating Grease Institute (NLGI) Standards

The National Lubricating Grease Institute (NLGI) classifies and grades grease lubricants according to consistency and the application for which it is used.

The NLGI also issues licensed labels that identify approved grease lubricant applications.

Extreme Pressure (EP) Lubricants

CAUTION

Do not use multi-viscosity or Extreme Pressure (EP) GL-5 gear oils in a manual transmission or transfer case. Damage to the transmission will result.

Extreme Pressure lubricants are often identified by the abbreviation EP. Extreme Pressure lubricants contain additives that provide extra anti-wear protection to heavily-loaded parts. EP greases or EP oils are required in various applications. Figure 1.1.

Approved hypoid gear oils contain EP additives that protect against tooth scoring and surface fatigue.

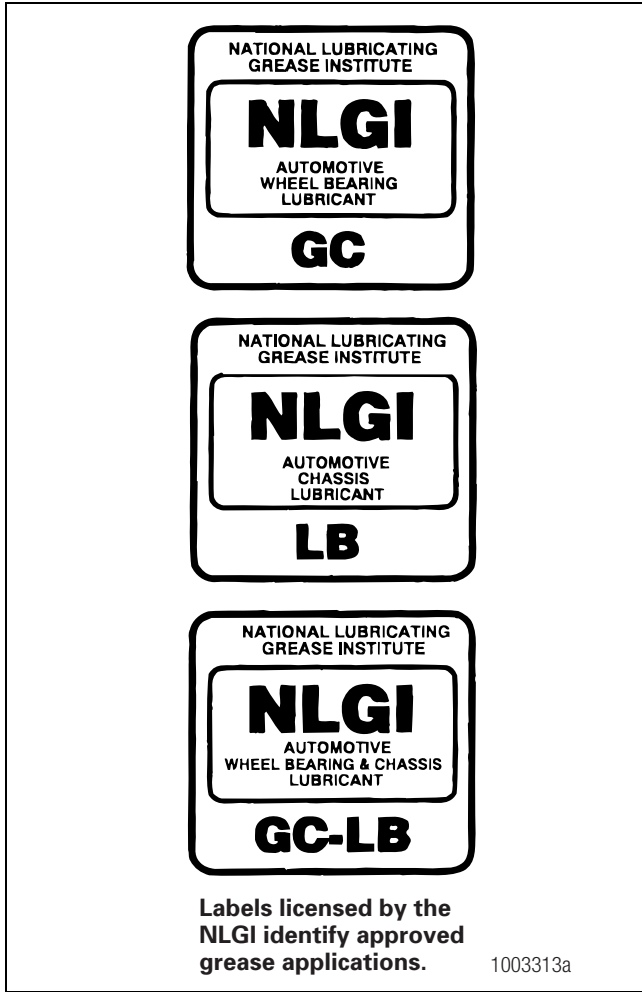

Figure 1.1

2 Bus and Coach

Hazard Alert Messages

Read and observe all Warning and Caution hazard alert messages in this publication. They provide information that can help prevent serious personal injury, damage to components, or both.

⚠ WARNING

To prevent serious eye injury, always wear safe eye protection when you perform vehicle maintenance or service.

Park the vehicle on a level surface. Block the wheels to prevent the vehicle from moving. Support the vehicle with safety stands. Do not work under a vehicle supported only by jacks. Jacks can slip and fall over. Serious personal injury and damage to components can result.

Technical Publications

How to Obtain Additional Maintenance and Service Information

Refer to the publications in Table C. To obtain these publications, refer to the Service Notes page on the front inside cover of this manual.

Table C: Publications

| Model | Manual |
|---|------------------------------|
| Bus and Coach Front Axles | Maintenance Manual 23 |
| Bus and Coach Rear Axles | Maintenance Manual 23A |
| Bus and Coach Brakes | Maintenance Manual 23B |
| Bus and Coach Gear Drive Drop Box for Axle Models S-162 and -163; SC-164 and -165 | Maintenance Manual 23C |
| Bus and Coach Inverted Portal Drive Axle | Maintenance Manual 23D |
| Bus and Coach Planetary Drive Axle/Model RC-26-633 | Maintenance Manual 23E |
| Bus and Coach RDC Wedge Brakes | Maintenance Manual 23F |
| Bus and Coach Electric Drive Axle | Maintenance Manual MM-9905-G |

Description

Meritor provides a wide selection of components to the transit bus and coach industry suited to the latest vehicle designs as well as for traditional applications. These include:

- Front non-drive steer axles — 17100, 17101, 17111, FH 941, FH 945 and FH 946
- Rear drive axles — 59000 Series, 61000 Series, 71000 Series and RC-23-160
- Center non-drive axles — 61000 Series, 71000 Series and RC-26-700
- Inverted portal drive axles — RC-26-720 and RC-27-720
- Planetary drive axle — RC-26-633
- Stopmaster® wedge brakes — RDC Series
- Cam brakes — Q Series, Q Plus™, Cast Plus™ and W Series
- Disc brakes — DiscPlus™ DX195 and DX225
- Parking brake — T Series

Front Axles

Seven Meritor front non-drive steer axle models are available for buses and coaches. Models 17110 and 17111 have an I-beam construction. Models 17100 and 17101 have a rectangular beam in the center. Figure 2.1. Models FH 941, FH 945 and FH 946 have an I-beam construction. Figure 2.2 and Figure 2.3.

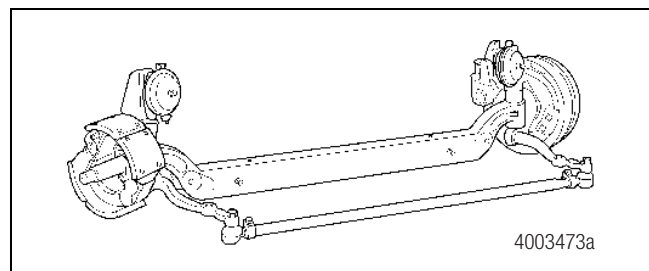

Figure 2.1

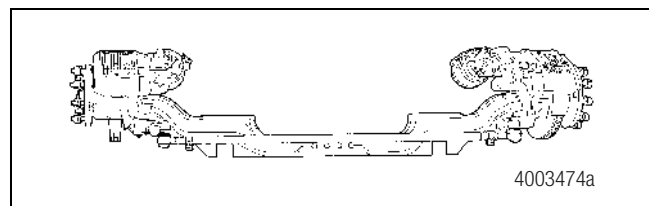

Figure 2.2

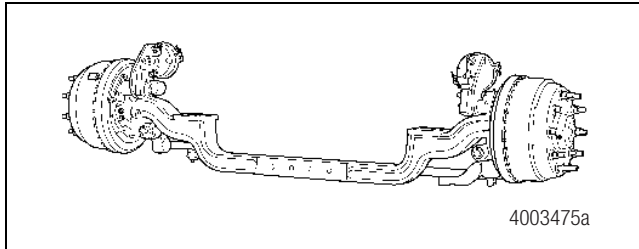

Figure 2.3

Rear Axles

The Meritor bus and coach rear drive axles are available in the 59000, 61000 and 71000 Series and RC-23-160.

59000 Series

The Meritor 59000 Series drive axles have the following features. Figure 2.4.

- Spiral bevel gearing is used in an angle drive carrier. The pinion is at a 63-degree angle to the axis of the axle shafts.
- Optional conventional single-reduction and double-reduction carriers with hypoid gearing are also available.
- A driveline parking brake is installed on the flange of some angle drive carriers.
- The housing is designed with replaceable axle tubes at the wheel spindles.

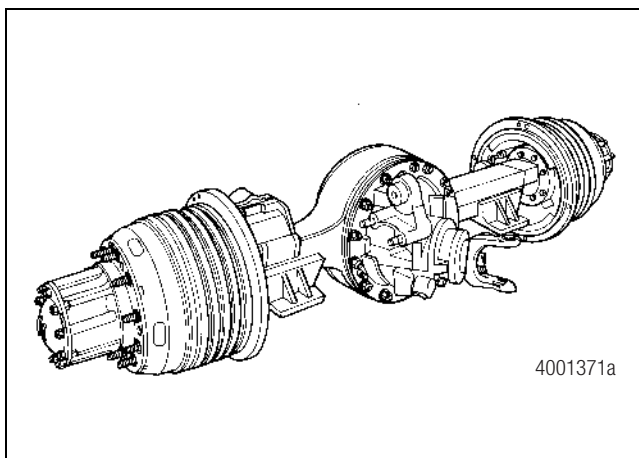

Figure 2.4

61000 Series

The Meritor 61000 Series drive axles have the following features. Figure 2.5.

- The single-reduction carrier is combined with a hypoid drive pinion and a ring gear.
- Optional double-reduction carriers are also available.
- The housing is designed with replaceable axle tubes at the wheel spindles.
- The housing has weld-on torque rod brackets.

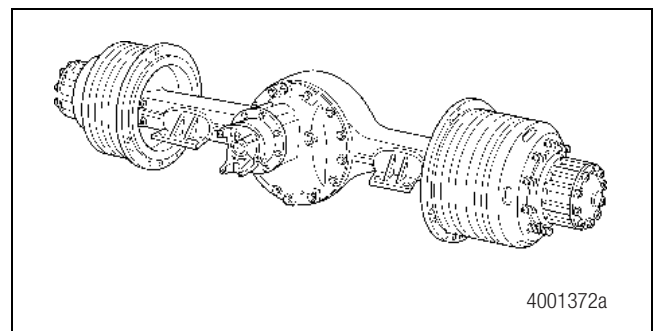

Figure 2.5

71000 Series

The Meritor 71000 Series drive axles have the following features. Figure 2.6.

- The single-reduction carrier is combined with a hypoid drive pinion and a ring gear.
- The housing is designed with replaceable axle tubes at the wheel spindles.
- The housing has bolt-on torque rod brackets.
- The axles are equipped with either S-cam or DiscPlus™ brakes.

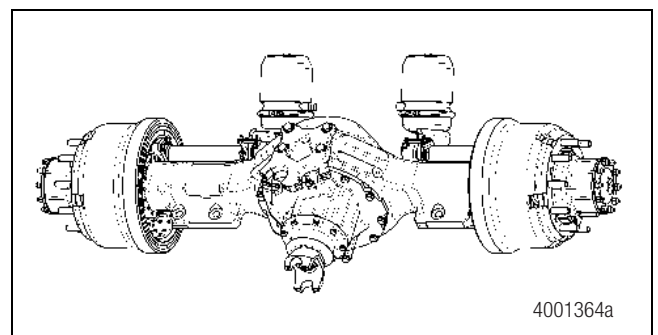

Figure 2.6

2 Bus and Coach

RC-23-160 Series

The RC-23-160 Series drive axles have the following features. Figure 2.5.

- The single-reduction carrier is combined with a hypoid drive pinion and a ring gear.
- The housing is designed without replaceable axle tubes at the wheel spindles.

Inverted Portal Drive Axle

The Meritor RC-26-720 and RC-27-720 inverted portal drive axles are double-reduction axles. The differences between the two models are the suspension bracketry configuration and the mounting of the brake chambers and automatic slack adjusters. Both axles feature spiral bevel and helical forged gearing with industry-standard wheel ends. All gears are ground to minimize the potential for gear noise. Figure 2.7.

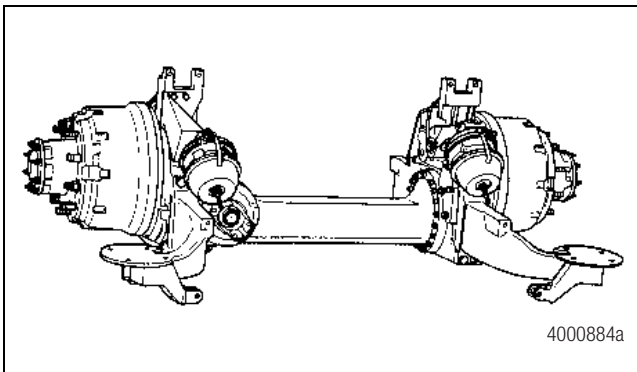

Figure 2.7

The axles feature a modular design that consists of five separate units:

- One center housing
- Two helical gear housings
- Two wheel ends

This modular design allows each module to be assembled and serviced independently for easier maintenance. Figure 2.8.

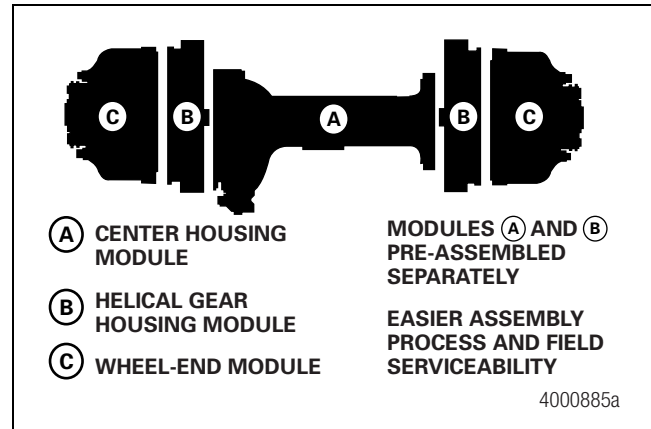

Figure 2.8

Planetary Drive Axle

The Meritor RC-26-633 is a double-reduction axle. The first reduction is in the carrier and the second reduction is in the wheel end. This allows for a smaller carrier ring gear and a lower bus floor. Special ground gearing in both the carrier and wheel end produces quieter operation. Figure 2.9.

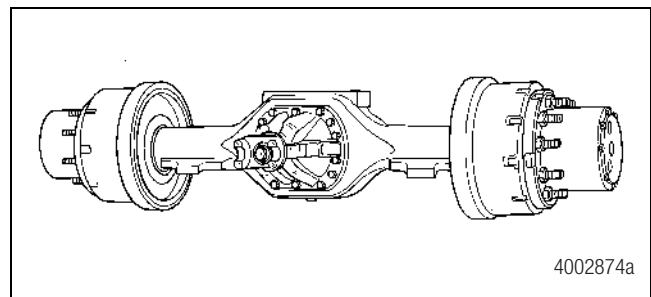

Figure 2.9

The axle is equipped with Meritor Cast Plus™ cam brakes with a 16.5-inch diameter and 8.62-inch wide heavy-duty cast shoes. The axle also is equipped with the anti-lock braking system sensor and tooth ring.

Center Axles

The Meritor bus and coach center axles are available in the 61000 and 71000 Series and RC-26-700.

61000 and 71000 Series

The 61000 and 71000 Series center axles have the following features.

- Center axles are identical to the 61000 and 71000 Series drive axles except without carriers or axle shafts.
- The spindle ends are capped so only the wheel end is filled with lubricant.
- A hubcap is used to keep lubricant in the wheel end instead of an axle shaft. Figure 2.10.

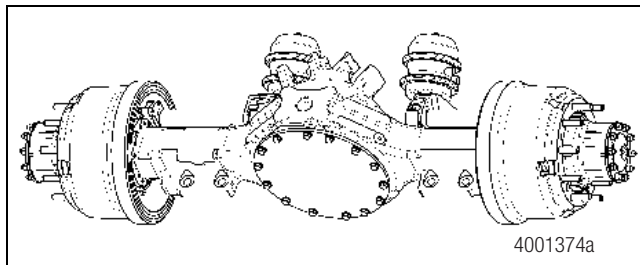

Figure 2.10

RC-26-700 Series

The RC-26-700 Series center axles feature the following.

- Tubular deep-drop axles are designed for low floor applications. Figure 2.11.

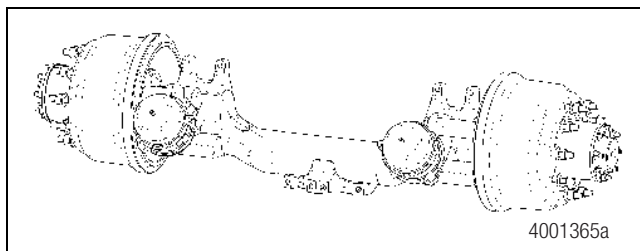

Figure 2.11

Important Information

Meritor automatic slack adjusters (ASAs) should not need to be manually adjusted in service. ASAs should not have to be adjusted to correct excessive pushrod stroke. The excessive stroke may be an indication that a problem exists with the foundation brake, ASA, brake actuator or other system components.

Meritor recommends troubleshooting the problem, replacing suspect components and then confirming proper brake operation prior to returning the vehicle into service.

In the event that a manual adjustment must be made (although not a common practice), a service appointment and full foundation brake, ASA, and other system component inspection should be conducted as soon as possible to ensure integrity of the overall brake system.

For Meritor brake adjustment, refer to the brake adjustment tables in Section 7. For non-Meritor brake adjusters, refer to the brake manufacturer's service procedures.

Cam Brakes

Meritor cam brakes are air-actuated, cam-operated, double shoe brakes with each shoe mounted on a separate anchor pin. The brakes are available with automatic or manual adjustment and can be assembled with auxiliary spring brakes.

There are three types of cam brakes for buses and coaches: Q Series and Q Plus™, Cast Plus™ and W Series.

Q Series and Q Plus™

The Q Series and Q Plus™ brake shoe has an open end on the anchor pin ends for "quick change" service. An anchor pin fastens each brake shoe to the spider. The linings are fastened to the brake shoes with rivets. Two retaining springs and one return spring hold the shoes together on the spider. Figure 2.12.

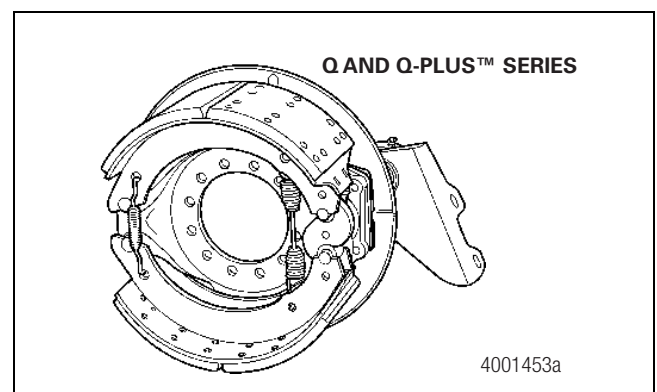

Figure 2.12

Q Series brakes are available in 16.5-inch diameter with a 10-inch width and 0.75-inch tapered brake lining. A 15-inch diameter is available for front non-drive applications.

Q Plus™ brakes are available in 16.5-inch (419 mm) diameter with 5-, 6-, 7- and 8.625-inch (127, 152, 178 and 219 mm) widths. The tapered brake linings are 0.75-inch (19.05 mm) thick.

2 Bus and Coach

Cast Plus™

The Cast Plus™ brake is designed for heavy-duty, off-highway and people-mover applications. A redesigned S-cam and heavy-duty shoe return spring allow additional shoe travel. An improved camshaft bushing contributes to longer service life. The Cast Plus™ brake uses Q Plus™ brake linings and the P Series brake shoe design. Figure 2.13.

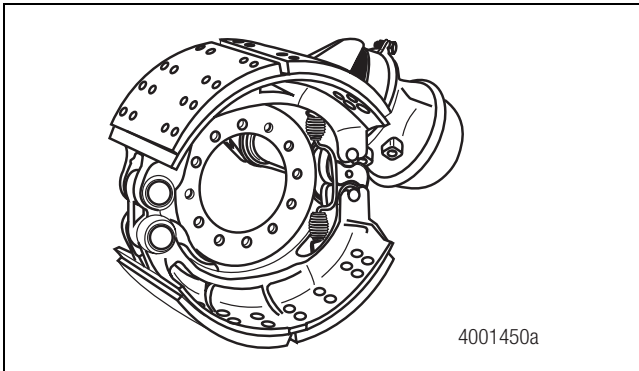

Figure 2.13

Cast Plus™ brakes are available in 16.5-inch (419 mm) diameter with 6- and 8.625-inch (152 and 219 mm) widths.

W Series

The W Series brake has anchor pins that fasten the brake shoe to the spider. The anchor pins can have a straight or tapered design. The spider can have an integral or separate cam bracket. The brake shoes are fastened to the linings with bolts. Figure 2.14.

W Series brakes are available in 14.5-inch (368 mm) diameter with 5-, 6-, 8- and 10-inch (127, 152, 203 and 254 mm) widths.

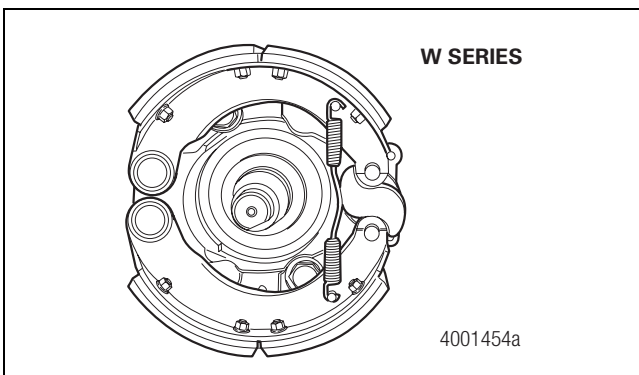

Figure 2.14

Important Information

Meritor automatic brake adjusters (ABAs) should not need to be manually adjusted in service. ABAs should not have to be adjusted to correct excessive pushrod stroke. The excessive stroke may be an indication that a problem exists with the foundation brake, ABA, brake actuator or other system components.

Meritor recommends troubleshooting the problem, replacing suspect components and then confirming proper brake operation prior to returning the vehicle into service.

In the event that a manual adjustment must be made (although not a common practice), a service appointment and full foundation brake, ABA, and other system component inspection should be conducted as soon as possible to ensure integrity of the overall brake system.

For Meritor brake adjustment, refer to the brake adjustment tables in Section 7. For non-Meritor brake adjusters, refer to the brake manufacturer's service procedures.

Stopmaster® Wedge Brakes

Meritor Stopmaster® brakes are wedge-actuated air brakes that are used on buses. The clearance between the drum and the linings is automatically adjusted. The brake support is a cast spider with plunger, actuation, housings. Stopmaster® brakes are available in the RDC Series.

RDC Series

The RDC Series brake is available in a 15.125-inch (384 mm) diameter. The brake shoes are available in 6-inch (152 mm) widths for front brakes and 10-inch (254 mm) widths for rear brakes. Air chambers on the rear brakes are larger than the air chambers on the front brakes. Bolts and nuts are used to fasten the linings to the shoes. The linings are tapered at each end of the shoe. The shoes engage the plungers at the tab on the top of each plunger assembly. The anchor plunger is a two-piece assembly that uses an anchor housing and a lock nut.

DiscPlus™ Brakes

DiscPlus™ DX195 and DX225 air disc brakes are optional on FF and FG bus and coach front steer axles. Brakes feature sealed calipers lubricated to protect components that actuate the brake. The brake is comprised of a lightweight single-piece cast caliper supported on twin fully seated slide pins fixed to a mounting saddle. Figure 2.15.

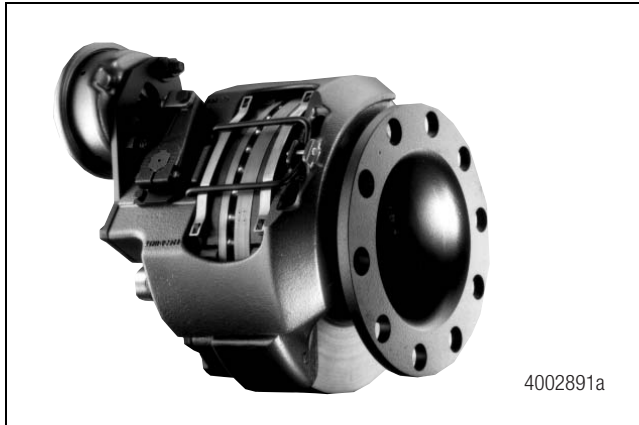

Figure 2.15

T Series Parking Brake

The 59000 Series parking brake is a Meritor T Series brake installed on the drive pinion bearing cage in the differential carrier.

- An air chamber with an automatic slack adjuster is attached to the parking brake camshaft.
- A brake drum is installed onto the yoke flange.
- The brake assembly has an outer diameter of 12-inches (304 mm).
- The brake shoes are 4.5-inches (114 mm) wide. Figure 2.16.

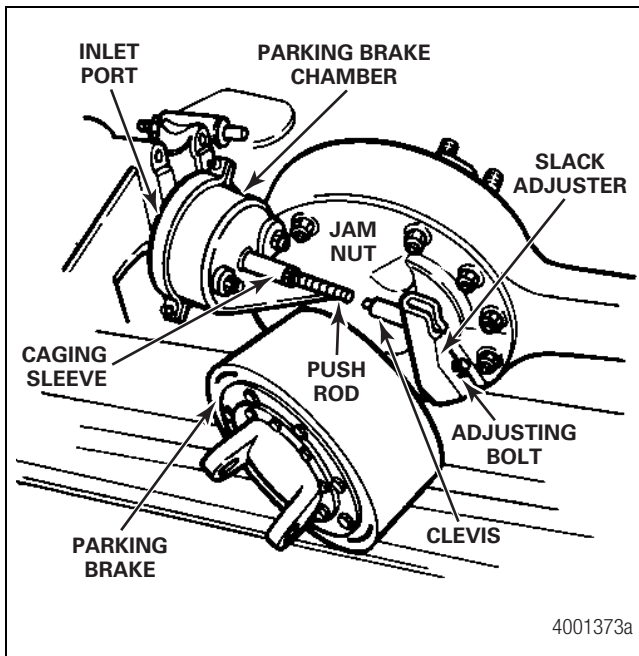

Figure 2.16

Identification

Model Nomenclature

Front Axles

The axle model identification plate is located on the axle center. Use the model number to obtain the correct parts from Meritor. Figure 2.17 and Figure 2.18.

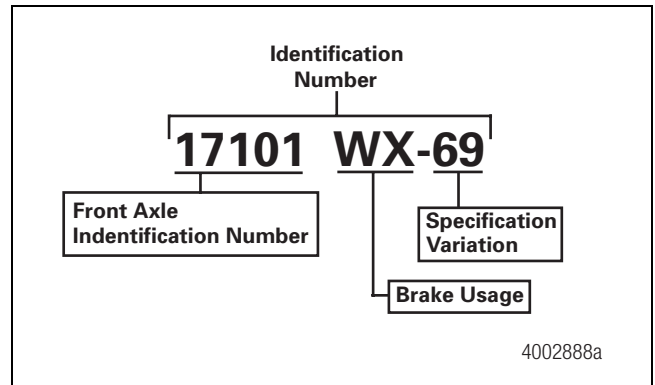

Figure 2.17

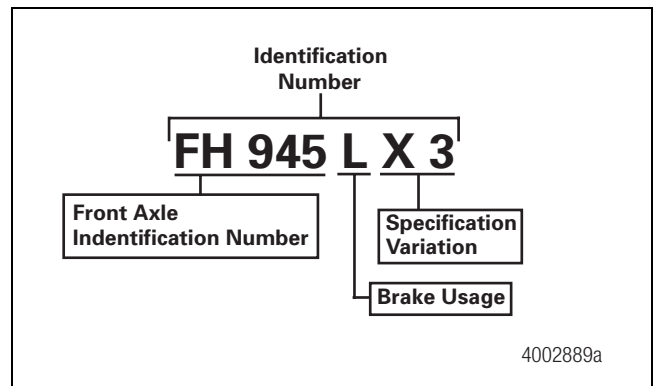

Figure 2.18

2 Bus and Coach

Rear Axles

An identification tag is located on the axle housing or the differential carrier. Use the model number and the ratio number marked on the tag to obtain replacement parts. Figure 2.19.

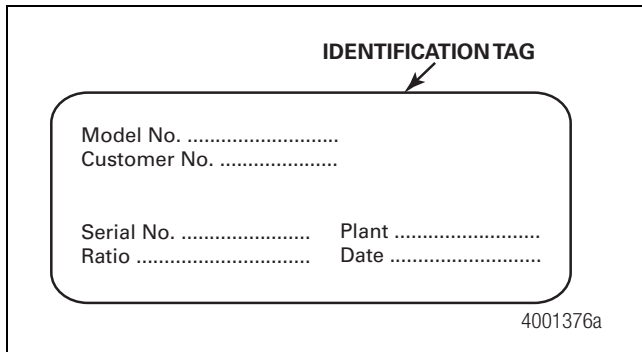

Figure 2.19

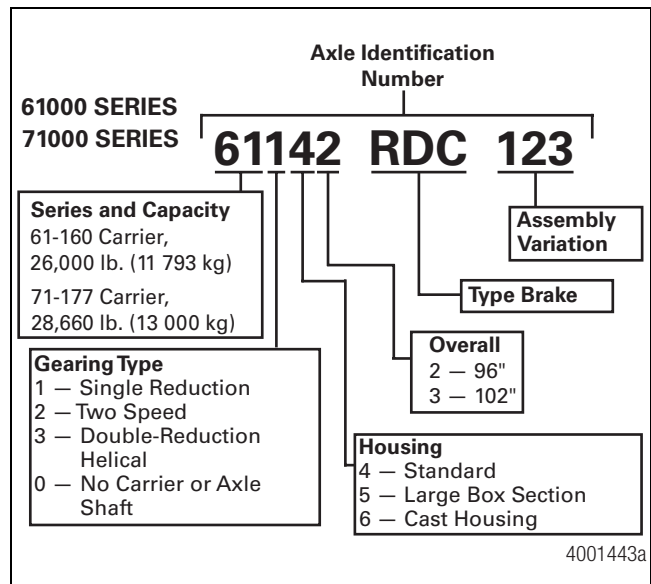

Figure 2.21

Figure 2.20 and Figure 2.21 explain the model number designation for the 59000, 61000 and 71000 Series axles.

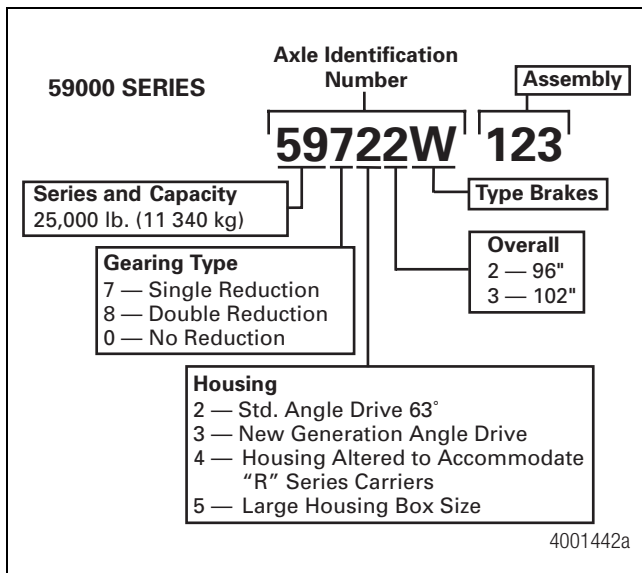

Figure 2.20

The RC-23-160 coach rear axle, RC-26-720 and RC-27-720 inverted portal axles and RC-26-633 planetary drive axle are identified by a letter and number system that provides information about the specific axle model. Figure 2.22. The first seven positions of the designation identify a basic axle model. The second group of letters and numbers identify complete axle specifications.

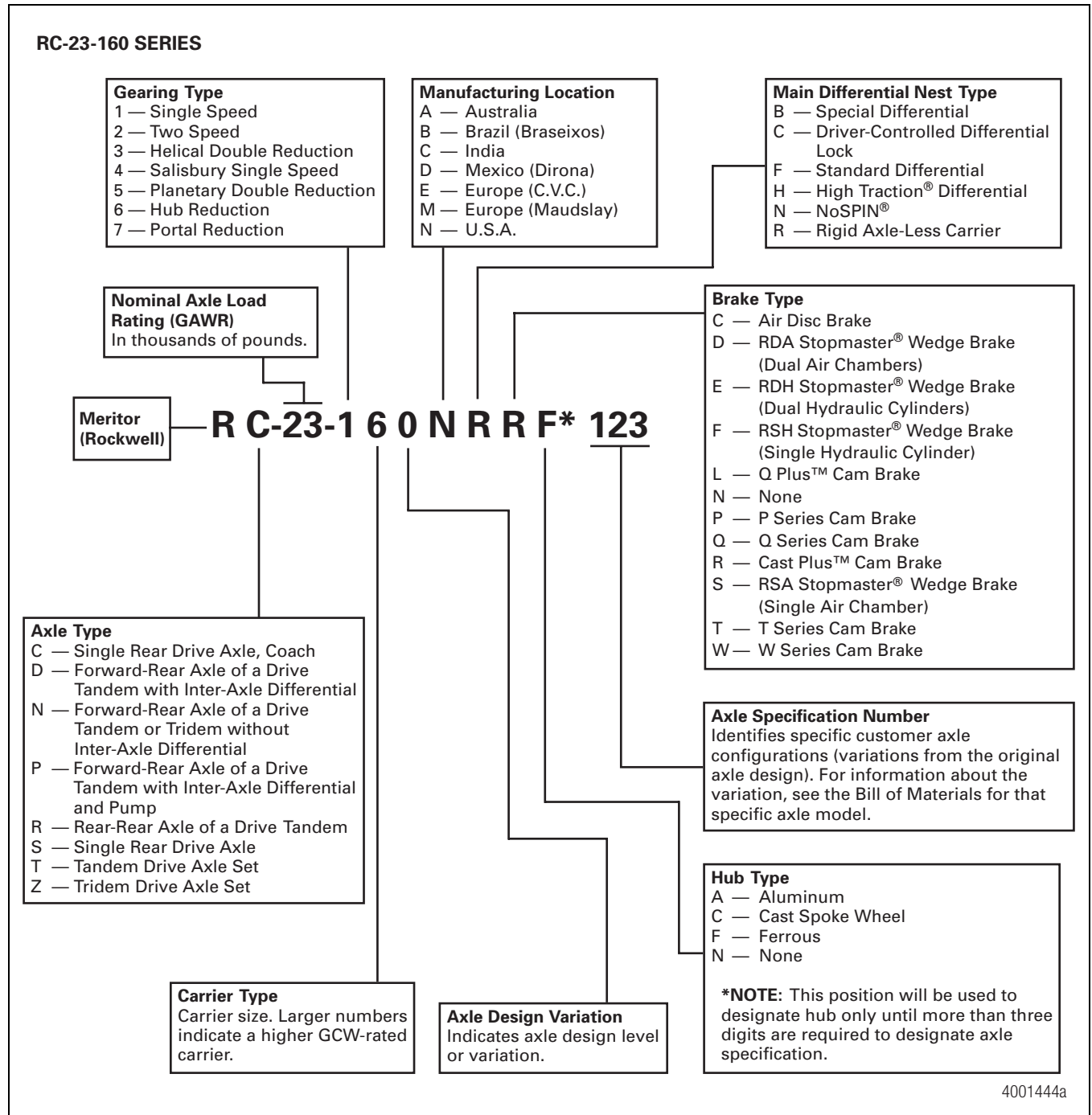

Figure 2.22

2 Bus and Coach

Cam Brakes

The brakes can be identified by a code on the axle identification plate. Figure 2.23.

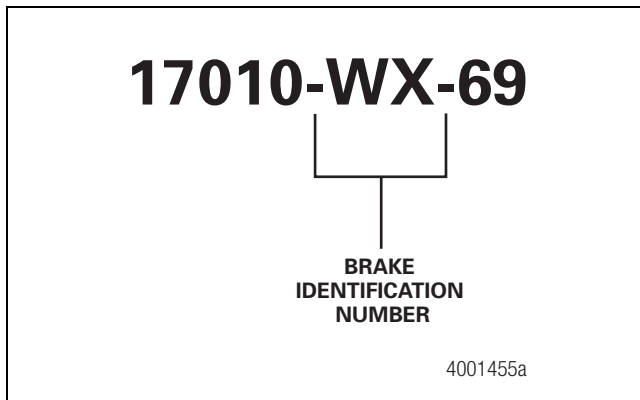

Figure 2.23

When parts are replaced, the correct parts must be used. Part numbers are found on the top of the camshaft, on the brake spider, on the brake shoes and on the air chamber bracket.

Wedge Brakes

Meritor Stopmaster® brakes are identified by a three-letter code on the axle identification plate. Figure 2.24 and Figure 2.25.

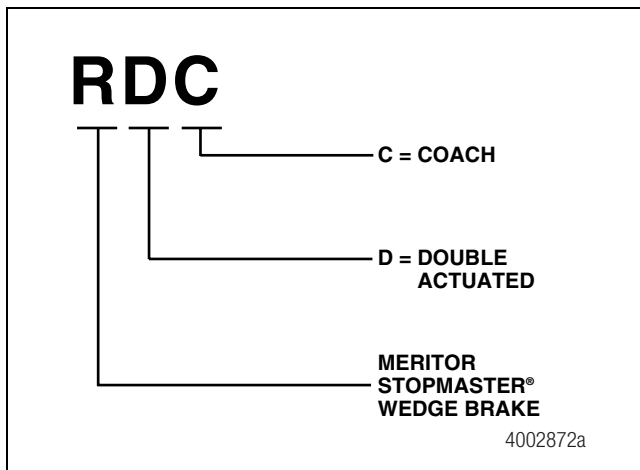

Figure 2.24

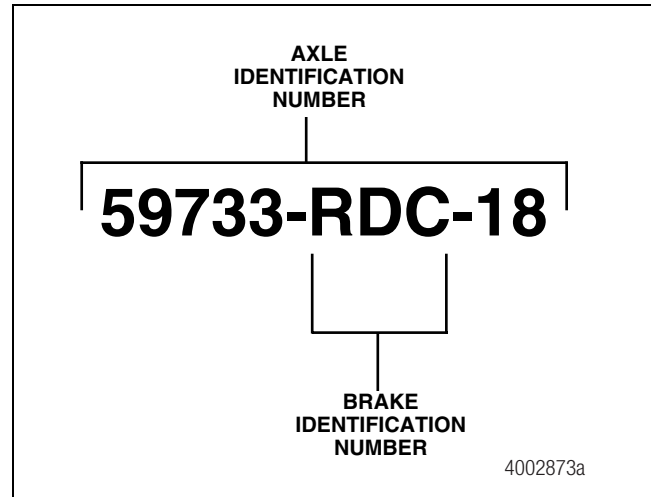

Figure 2.25

When using replacement parts, verify that the correct parts are used. Part numbers are found on the brake spider and the brake shoes.

Inspection

Front Axles

Inspect components during regularly scheduled maintenance intervals to ensure correct operation and maximize the life of the parts.

⚠ WARNING

Replace damaged or out-of-specification axle components. Do not bend, repair or recondition axle components by welding or heat-treating. A bent axle beam reduces axle strength, affects vehicle operation and voids Meritor's warranty. Serious personal injury and damage to components can result.

Fasteners

Verify that all fasteners are tightened to the specified torque. Use a torque wrench to check the torque in a tightening direction. As soon as the fastener starts to move, record the torque. Correct if necessary. Replace any worn or damaged fasteners.

Wear and Damage

Inspect the parts of the axle for wear and damage. Look for bent or cracked parts. Replace all worn or damaged parts.

Pivot Points

Verify that looseness does not exist at the pivot points. Verify that the pivot points are lubricated.

Operation

Verify that all the parts move freely through the complete turning radius.

Tire Wear

Inspect the tires for wear patterns that indicate suspension damage or misalignment.

Steering Arm Bolts

Check the torque every 200,000 miles (320 000 km).

Lubrication

King Pin Bushings

1. Park the vehicle on a level surface. Block the wheels to prevent the vehicle from moving. Set the parking brake.
2. Verify that the tires touch the ground. Do not raise the vehicle. The full weight of the vehicle must be on the axle assembly. Figure 2.26.

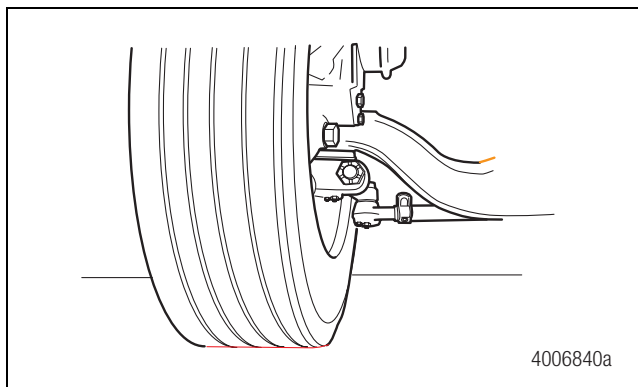

Figure 2.26

3. Clean all grease fittings before you lubricate the king pins.
4. Lubricate the king pins through the top and bottom grease fittings. Figure 2.27.

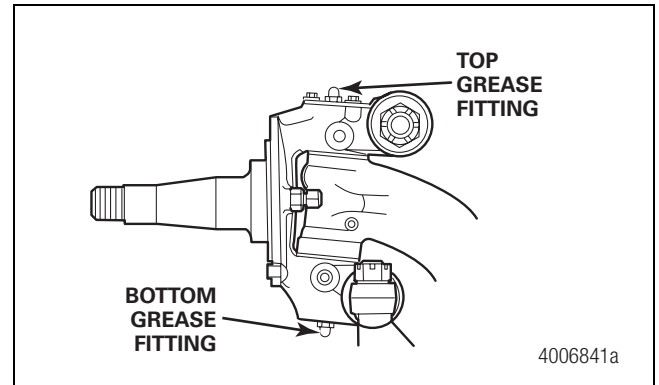

Figure 2.27

5. Apply lubricant into the top grease fitting until new grease purges from the upper shim pack. Figure 2.28.

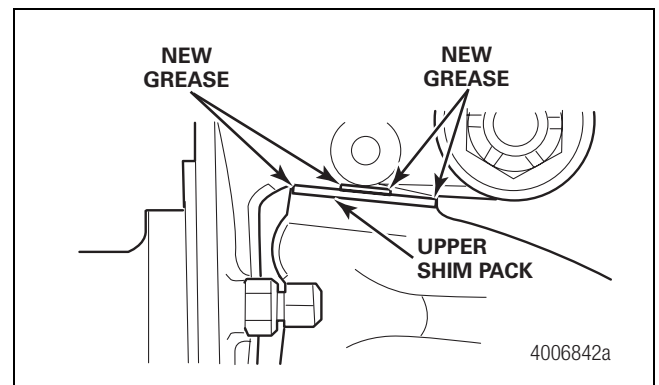

Figure 2.28

6. Apply lubricant into the bottom grease fitting until new grease appears from under the lower lip of the bearing deflector. Figure 2.29.

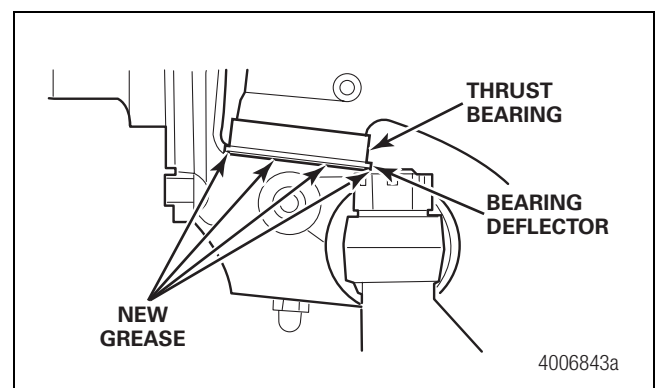

Figure 2.29

2 Bus and Coach

Tie Rod

1. Park the vehicle on a level surface. Block the wheels to prevent the vehicle from moving. Set the parking brake.
2. Verify that the tires touch the ground. Do not raise the vehicle.
3. Clean and remove the oil grease fittings prior to lubrication.
4. Apply lubricant at each grease fitting until new lubricant flows from the boot.

Grease-Lubricated Wheel Bearings

1. Park the vehicle on a level surface. Block the wheels to prevent the vehicle from moving.
2. Raise the vehicle so that the wheels are off the ground. Support the vehicle with safety stands.
3. Remove the tire and wheel assembly. Remove and disassemble the hub.
4. Use the correct cleaning solvent to remove the old grease from all parts. Discard the seals. Inspect the wheel bearings for wear or damage. Replace worn or damaged bearings.
5. Before installing the wheel bearings, lubricate the bearing journals on the spindle with the grease that is used for the bearings. Figure 2.30.

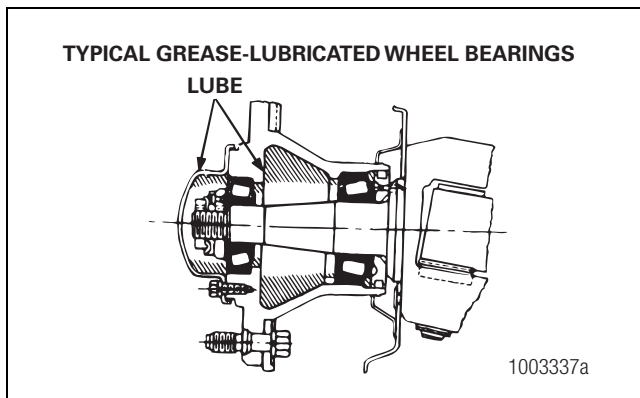

Figure 2.30

6. Use a pressure packer to force the specified grease from the large end of the cones into the cavities between the rollers and cage. Pack the hub between the bearing cups with grease to the level of the smallest diameter of the cups.
 - **If a pressure packer is not available:** Grease the bearings by hand.

7. Install the inner and outer bearing cones into the cups in the hubs. The bearing cups must be pressed tight against the shoulder in the hubs.
8. Install new wheel seals into the hubs.
9. Install the hub and the wheel and tire assembly. Install the outer wheel bearing cone into the hub. Install the adjusting nut.
10. Adjust the wheel bearings.

Oil-Lubricated Wheel Bearings

NOTE: If you cannot observe the oil level because the sightglass is stained, remove the fill plug, check the oil level with your finger and follow the procedures for Step 3 below. Replace the stained sightglass as soon as possible.

1. Park the vehicle on a level surface. Block the wheels to prevent the vehicle from moving.
2. Check the oil level on the cap.
3. If the oil level is more than 0.25-inch (6 mm) below the specified level on the cap, remove the fill plug.
4. Add the specified oil to the specified level. Figure 2.31.

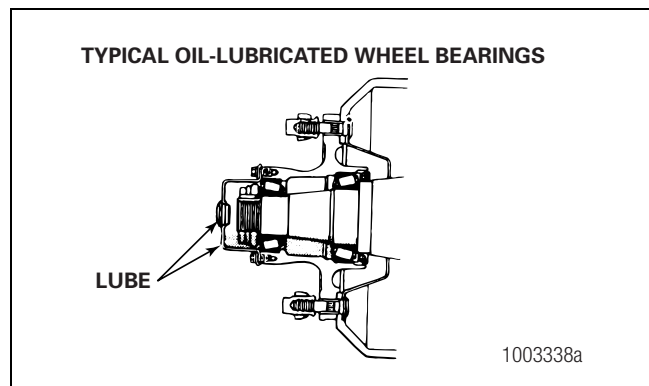

Figure 2.31



5. Install the fill plug.

Rear Axles

Inspection

Inspect components during regularly scheduled maintenance intervals to ensure correct operation and maximize the life of the parts.

Drain and Replace the Oil

1. Park the vehicle on a level surface. Block the wheels to prevent the vehicle from moving. The axle lubricant capacity changes when the drive pinion angle changes.
2. Place a drain pan under the axle. Remove the drain plug from the bottom of the axle housing. Drain the lubricant. Install the drain plug and tighten to 35 lb-ft (47 N•m). 
3. Remove the fill plug from the side of the axle housing bowl cover.
4. Add the axle lubricant through the fill plug hole. Fill the axle with the lubricant until the lubricant level is even with the bottom of the fill plug hole.
5. Install the fill plug. Tighten the plug to 35 lb-ft (47 N•m) minimum. When correctly installed, one complete thread of the fill plug is visible between the housing and the plug head. 
 - **If the axle shafts or hubs are equipped with oil fill plugs:** Rotate the hub until the fill plugs are at the top. Remove the oil fill plugs. Fill each hub cavity with 2 pints (1 L) of rear axle lubricant. Install and tighten the fill plugs to 10 lb-ft (13.8 N•m) minimum. 
 - **If the axle shafts and hubs are not equipped with oil fill plugs:** Slowly drive each side of the vehicle over a 6-inch (152.4 mm) raised surface so that the oil can flow out to the hubs. Check the oil level in the housing and refill to the bottom of the fill plug.
6. Road test the vehicle in an unloaded condition for 1-2 miles (1.6-3.2 km) at speeds not more than 25 mph (40 km/h). Recheck the lubricant levels and all of the fasteners. Adjust as necessary.

Inverted Portal Drive Axle

Inspect Magnets

Inspect and clean the magnets located on the drain plug of each helical gear case and on the axle center housing drain plug.

- **If excessive debris is found on a magnet:** Inspect all components for the source of the debris.

Drain and Replace the Oil

1. Park the vehicle on a level surface. Block the wheels to prevent the vehicle from moving. The axle lubricant capacity changes when the drive pinion angle changes.

2. Place a drain pan under the axle. Remove and drain the oil from the two drain plugs on the lower side of the helical gear housing and the plug below the carrier in the center housing. Install the drain plugs and tighten them to 35 lb-ft (47 N•m). Figure 2.32. 

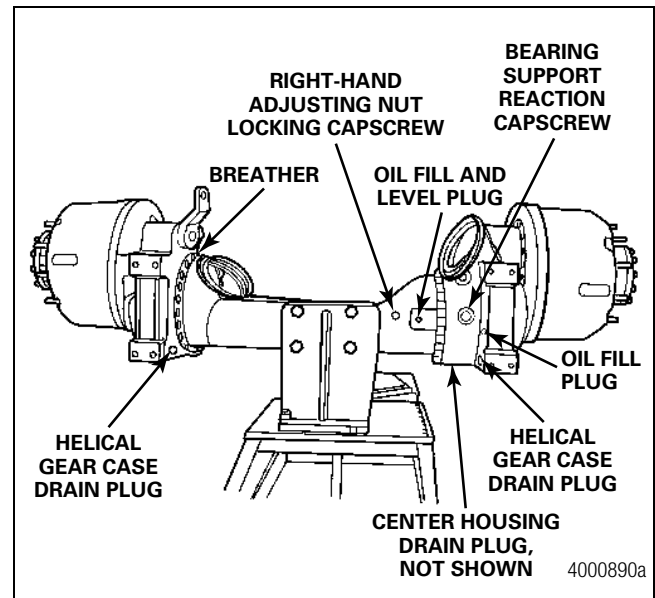





Figure 2.32

3. Remove the fill plug from the helical gear case that is closest to the differential. Figure 2.32.
4. Fill the helical gear case with approximately 1.6 gallons (6 liters) of lubricant until the lubricant level is even with the bottom of the fill hole. Install the fill plug. Tighten the plug to 35 lb-ft (47 N•m). 
5. Remove the fill plug from the side of the axle housing bowl cover. Figure 2.32.
6. Fill the axle housing with approximately 5 gallons (19 liters) of lubricant until the lubricant is level with the bottom of the fill hole.
7. Wait five minutes. Add lubricant to the axle center housing until the lubricant is level with the bottom of the fill hole. Repeat this step until the oil level in the axle center housing does not drop.
8. Install the fill plug. Tighten the plug to 35 lb-ft (47 N•m). When correctly installed, one complete thread of the fill plug is visible between the housing and the plug head. 
9. Road test the vehicle in an unloaded condition for 1-2 miles (1.6-3.2 km) at speeds not more than 25 mph (40 km/h). Recheck the lubricant levels and all of the fasteners. Adjust as necessary.

2 Bus and Coach

Inverted Portal Drive Axle Wheel Ends

NOTE: If the axle shafts or hubs are equipped with oil fill plugs, fill the wheel ends with oil using the following procedure.

1. Park the vehicle on a level surface. Block the wheels to prevent the vehicle from moving.
2. Use a jack to raise the vehicle so that the wheels to be serviced are off the ground. Support the vehicle with safety stands.
3. Rotate the hub until the fill plugs are at the top.
4. Remove the oil fill plugs. Fill each hub cavity with 2 pints (0.95 liters) of the recommended rear hub axle lubricant.
5. Install and tighten the fill plugs to 10 lb-ft (14 N•m). 

Planetary Drive Axles

Inspect the Thrust Button, Thrust Screw and Coupling

NOTE: As a preventive maintenance procedure, you must inspect the internal components of the wheel ends every 24,000 miles (39 000 km) or at every brake reline, whichever comes first.

NOTE: Thrust surfaces can wear a combined total of 0.08-inch (2 mm) from their original position. If the wear is greater than 0.08-inch (2 mm), you must disassemble the wheel end and inspect the internal parts for wear.

1. Inspect the thrust button and thrust screw.
 - **If a groove or recess is worn into the thrust button face, from contact with the thrust screw:** Replace the thrust button.
 - **If the slotted end of the thrust screw is worn or shows signs of mushrooming or galling:** Replace the thrust screw.



NOTE: Slide the coupling back on the shaft for inspection. Do not remove it.

2. Inspect the coupling on the axle shaft for wear. The thickness of a new coupling is 0.24-inch (6 mm), with an allowable surface wear of 0.039-inch (1 mm) along any groove. Measure the thickness of the coupling along the thinnest part of the groove. If any measurement is 0.20-inch (5 mm) or less, replace the coupling.
 - **If the coupling thickness is less than the limits above:** Replace the coupling.

3. Inspect the thrust washer on the end of the spindle for wear or damage, especially around the flange area.
 - **If the thrust washer is worn, grooved or shows signs of galling:** Replace the thrust washer.

Drain and Replace the Oil

NOTE: The RC-26-633 axle has a common oil level between the carrier and the wheel ends. Three locations must be filled. The vehicle must be on a level surface when filling. Fill to the bottom of each fill plug hole, same as the axle horizontal center line.

1. Park the vehicle on a level surface. Block the wheels to prevent the vehicle from moving.
2. Use a jack to raise the vehicle so that the wheels to be serviced are off the ground. Support the vehicle with safety stands.
3. Remove the wheel nuts, and tire and rim assemblies from both wheel ends.
4. Rotate the wheel ends so the drain plug in the spider is at the BOTTOM. Place a drain pan under the wheel ends. Remove the plug and drain the lubricant from both wheel ends. Install the plug and tighten it to 18-25 lb-ft (24-34 N•m). 
5. Place a drain pan under the axle housing. Remove the plug from the bottom of the axle housing. Drain the lubricant from the carrier center section. Install the plug.
6. Fill the wheel ends and the carrier center section with a multigrade API GL-5 gear oil approved under MIL-PRF-2105E specification.
 - The carrier fill plug is located in the axle housing bowl. Figure 2.33.
 - **Original design wheel ends:** Rotate the wheel ends so the fill plug gives a level the same as the axle horizontal center line. Figure 2.34.
 - **Revised design wheel ends:** Rotate the wheel end until the fill hole is at the TOP. Remove the oil level capscrew and copper washer located in the center of the thrust screw. Do not remove the thrust screw and lock nut. Fill until oil comes out of the level hole in the center of the wheel end. Install the copper washer and oil level capscrew. Tighten the capscrew to 8 lb-ft (11 N•m). Figure 2.35. 

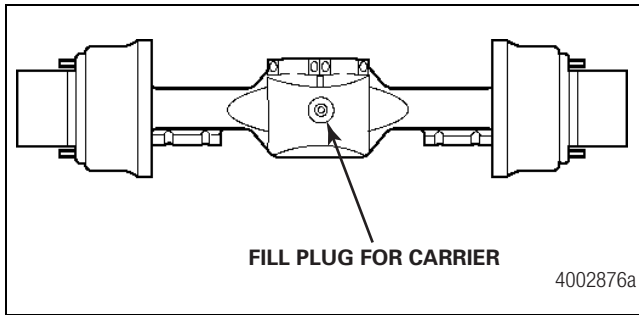

Figure 2.33

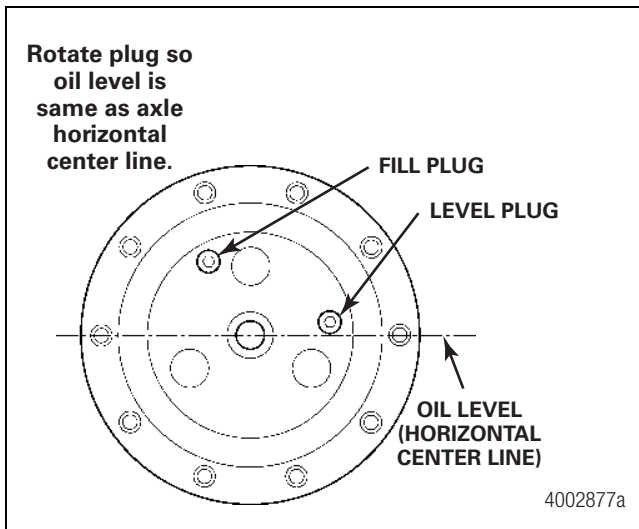

Figure 2.34

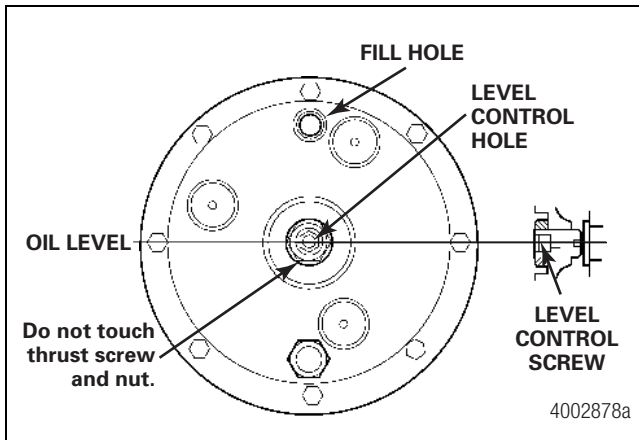

Figure 2.35

Cam Brakes

⚠ WARNING

During lubrication procedures, if grease flows from the seal near the camshaft head, replace the seal. Remove all grease or oil from the camshaft head, rollers and brake linings. Always replace linings contaminated with grease or oil, which can increase stopping distances. Serious personal injury and damage to components can result.

For lubrication information, refer to Table M and Figure 2.36, Figure 2.37 or Figure 2.38.

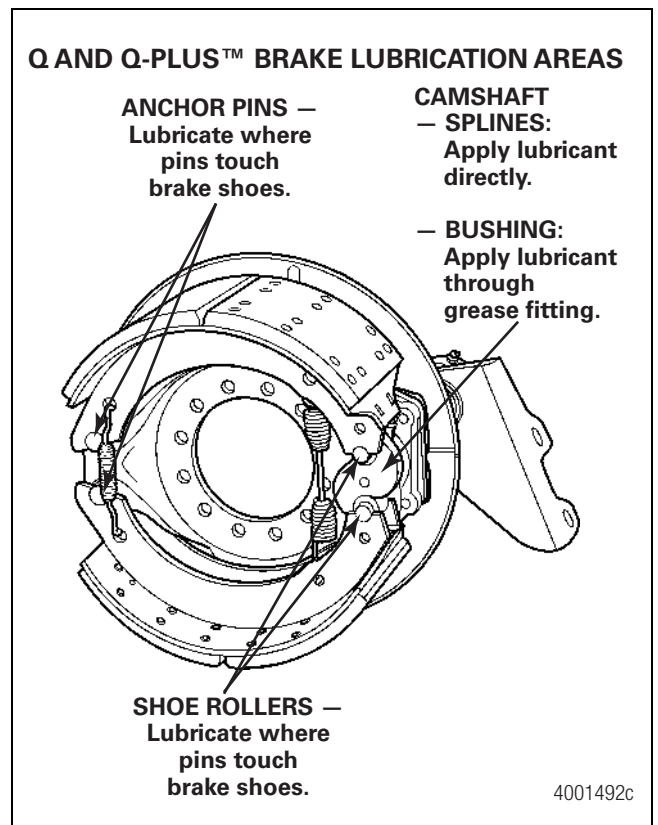

Figure 2.36

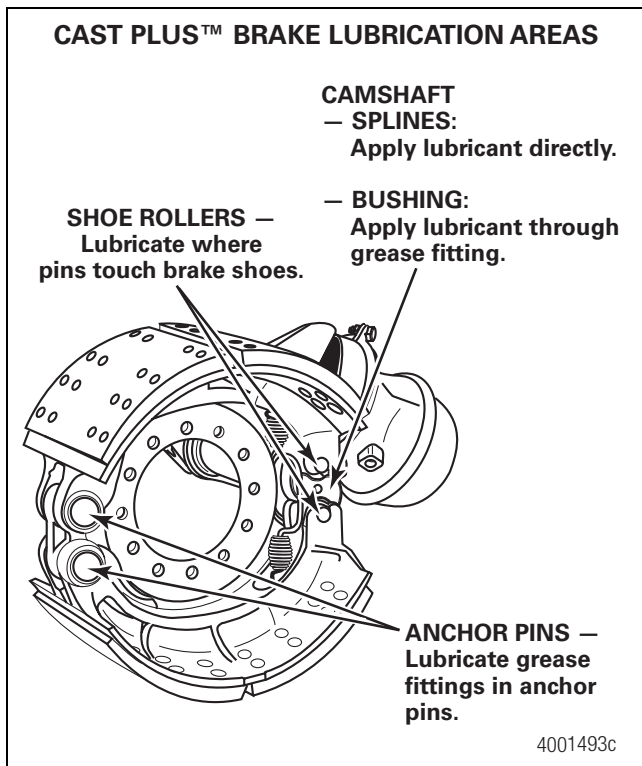

Figure 2.37

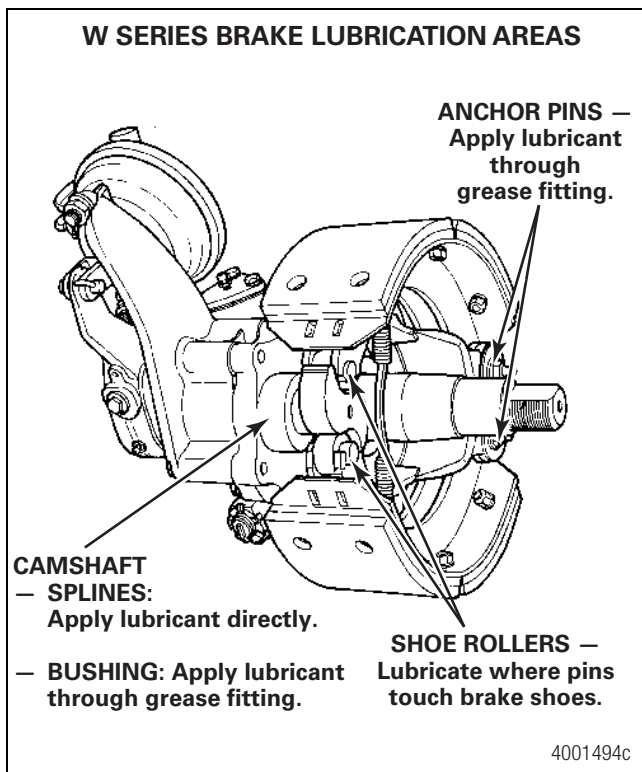

Figure 2.38

T Series Parking Brake

Camshaft Bushings

⚠ WARNING

During lubrication procedures, if grease flows from the seal near the camshaft head, replace the seal. Remove all grease or oil from the camshaft head, rollers and brake linings.

Always replace linings contaminated with grease or oil, which can increase stopping distances. Serious personal injury and damage to components can result.

Lubricate the camshaft bushings initially at 30,000 miles (48 280 km), then every 50,000 miles (80 467 km) or once a year, whichever comes first. Lubricate the camshaft bushings through the fittings in the differential carrier and the fitting in the drive pinion bearing cage.

Camshaft Splines

Lubricate the camshaft splines when necessary or when the brake is disassembled. Apply the lubricant to the camshaft splines.

Figure 2.39.

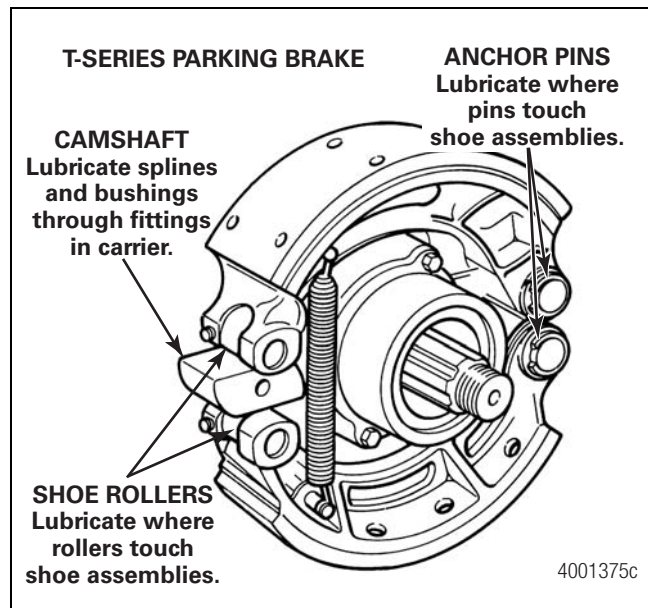

Figure 2.39

Anchor Pins

Lubricate the anchor pins when necessary or when the brake is disassembled. Apply the lubricant to the anchor pins where the pins touch the brake shoes. Figure 2.39.

Shoe Rollers

Lubricate the shoe rollers when necessary or when the brake is disassembled. Apply the lubricant to the roller pins where the pins touch the brake shoes. Do not apply lubricant on the part of the roller that touches the cam head. Figure 2.39.

Stopmaster[®] Brakes

Lubricant Areas

Lubricate the following areas of the brake.

- The outer diameter, the ramp and the slot of the anchor plungers
- The outer diameter, the inner diameter, the ramp and the slot of the adjusting plungers
- The teeth on the outer diameter and the threads on the inner diameter of the actuators
- The teeth and the outer diameter of the adjusting pawls
- The rollers and the head of the wedge assemblies
- The plunger bores and the bore for the pawl in the plunger housing

2 Bus and Coach

Lubrication Intervals and Specifications

Table D: Front Non-Drive Axle Greasing

| Component | Greasing Interval | Grease | Meritor Specification | NLGI Grade | Grease Type | Outside Temperature |
|--|--|----------------------|-----------------------|------------|---|---|
| King Pins and Bushings | 30,000 miles (48 280 km) or every preventive maintenance interval, whichever comes first | Multi-Purpose Grease | O-617-A | 1 | Lithium 12 Hydroxystearate or Lithium Complex | Refer to the grease manufacturer's specifications for the temperature service limits. |
| Ball Studs on Steering Arm, Tie Rod Ends, and Drag Link* | | | O-617-B | 2 | | |

* Applies to ball studs on Easy Steer Plus™ axles. Sealed axles require inspection of the boot on the ball stud every 100,000 miles (160 000 km) for wear and damage. Service as necessary.

Table E: Wheel-End Oil Change Intervals and Specifications

| On-Highway Operation Intervals | | | | | Outside Temperature | | | |
|--------------------------------|--------------------------|------------------------|----------------------------|----------------------------|---|------|------|------|
| Check Oil Level | Petroleum Oil Change | Meritor Specifications | Military Specification | Oil Description | °F | | °C | |
| | | | | | Min. | Max. | Min. | Max. |
| 1,000 miles (1600 km) | Whichever comes first: | O-76A Gear Oil | MIL-L-2105-D | GL-5, SAE 85W/140 | 10 | None | 12 | None |
| | | O-76D Gear Oil | | GL-5, SAE 80W/90 | -15 | None | -26 | None |
| | | O-76E Gear Oil | | GL-5, SAE 75W/90 | -40 | None | -40 | None |
| | Seals replaced | O-76E Gear Oil | | GL-5, SAE 75W/90 | -40 | None | -40 | None |
| | Brakes relined | O-76J Gear Oil | | GL-5, SAE 75W | -40 | 36 | -40 | 2 |
| | 30,000 miles (48 280 km) | Twice a year | Heavy-Duty Engine Oil | MIL-L-2104-B, -C, -D or -E | A.P.I. -CD, -CE, -SF or -SG SAE 40 or 50 ¹ | 10 | None | 12 |
| | Heavy-Duty Engine Oil | | MIL-L-2104-B, -C, -D or -E | | A.P.I. -CD, -CE, -SG, -SH or -SJ SAE 30 ² | -15 | None | -26 |

¹ Current designations are acceptable. Multi-grade engine oils are acceptable if the SAE rating ends in 40 or 50.

² Current designations are acceptable. Multi-grade engine oils are acceptable if the SAE rating ends in 30.

Table F: Rear Axle Lubricant Cross Reference (Viscosity and Temperature)

| Meritor Lubricant Specification | Description | Cross Reference | Minimum Outside Temperature | Maximum Outside Temperature |
|---------------------------------|-----------------|-------------------|-----------------------------|-----------------------------|
| 0-76-A | Hypoid Gear Oil | GL-5, SAE 85W/140 | +10°F (-12°C) | * |
| 0-76-B | Hypoid Gear Oil | GL-5, SAE 80W/140 | -15°F (-26°C) | * |
| 0-76-D | Hypoid Gear Oil | GL-5, SAE 80W/90 | -15°F (-26°C) | * |
| 0-76-E | Hypoid Gear Oil | GL-5, SAE 75W/80 | -40°F (-40°C) | * |
| 0-76-J | Hypoid Gear Oil | GL-5, SAE 75W | -40°F (-40°C) | +35°F (+2°C) |
| 0-76-L | Hypoid Gear Oil | GL-5, SAE 75W/140 | -40°F (-40°C) | * |

*There is no upper limit on these outside temperatures, but the axle sump temperature must never exceed +250°F (+121°C).

Table G: Meritor Wheel-End Axle Greasing Intervals and Specifications

| Greasing Interval | Meritor Grease | NLGI Specification | Grease Grade | Outside Classification | Temperature |
|--|----------------------|--|--------------|---|---|
| Whichever comes first: Replacing seals Relining brakes 30,000 miles (50 000 km)/ Once a year | Multi-purpose grease | 0-617-A (preferred) or 0-617-B (acceptable) | 1 or 2 | Lithium 12-Hydroxy Stearate or Lithium Complex | Refer to the grease manufacturer's specifications for the temperature service limits. |

Table H: Rear Axle Lubricant Schedule

| Type of Service | Check Oil Level | Oil Change Interval |
|---|-----------------------------------|---|
| Bus and Coach City Service | Every 3,000 miles (4828 km) | Less than 60,000 miles (96 558 km) a year: Change two times per year More than 60,000 miles (96 558 km) a year: Change every 25,000-30,000 miles (40 233-48 279 km) |
| Coach Highway Operation (Inter-city) | Every 3,000 miles (4828 km) | Petroleum-based oil* Initial drop at 1,000 miles (1609 km) 100,000 miles (160 930 km) or once per year, whichever is first Synthetic-based oil* No initial drop required Change every 250,000 miles (402 325 km) |

* Do not use synthetic-base oil for RC-26-633, RC-2'6-720 and RC-27-720 Series axles.

2 Bus and Coach

Table I: Lubricant Capacities

| Axle Model | U.S. Pints* | Liters* |
|-------------------|--------------------|----------------|
| 59722 | 30.5 | 14.4 |
| 59723 | 30.5 | 14.4 |
| 59732 | 30.5 | 14.4 |
| 59733 | 30.5 | 14.4 |
| 59752 | 30.5 | 14.4 |
| 59753 | 30.5 | 14.4 |
| 59842 | 30.5 | 14.4 |
| 59843 | 30.5 | 14.4 |
| 61042 | 41.0 | 19.4 |
| 61043 | 41.0 | 19.4 |
| 61052 | 41.0 | 19.4 |
| 61053 | 41.0 | 19.4 |
| 61063 | 44.0 | 20.8 |
| 61142 | 41.0 | 19.4 |
| 61143 | 41.0 | 19.4 |
| 61152 | 41.0 | 19.4 |
| 61153 | 41.0 | 19.4 |
| 61163 | 44.0 | 20.8 |
| 71063 | 44.0 | 20.8 |
| 71163 | 44.0 | 20.8 |
| RC-23-160 | 41.0 | 19.4 |
| RC-26-633 | 35.5 | 16.8 |
| RC-26-720 | 52-56.8 | 24.6-26.9 |
| RC-27-720 | 52-56.8 | 24.6-26.9 |

* These quantities are approximate. Fill the housing with oil up to the bottom of the oil fill hole in the housing cover. If the wheel ends have been disassembled, oil must be provided to the wheel ends before the vehicle is placed back into service.

Table L: Planetary Drive Axle Specifications

| A.P.I. Specification | SAE Grade | Meritor Specification | Outside Temperature | |
|-----------------------------|------------------|------------------------------|----------------------------|----------------|
| | | | Minimum | Maximum |
| GL-5 | 80W/90 | 0-76D | -15°F (-26°C) | None |
| GL-5 | 75W/90 | 0-76E | -40°F (-40°C) | None |

Table J: Planetary Drive Axle Intervals

| Initial Oil Change | Oil Change |
|---------------------------|--------------------------|
| 2,500 miles (4023 km) | 25,000 miles (40 233 km) |

Table K: Planetary Drive Axle Lubricant Capacities

| Carrier Center Section | Each Wheel End |
|-------------------------------|------------------------|
| 35.5 pints (16.7 liters) | 7.0 pints (3.3 liters) |

⚠ WARNING

During lubrication procedures, if grease flows from the seal near the camshaft head, replace the seal. Remove all grease or oil from the camshaft head, rollers and brake linings. Always replace linings contaminated with grease or oil, which can increase stopping distances. Serious personal injury and damage to components can result.

For lubrication information, refer to Table M and Figure 2.36, Figure 2.37 or Figure 2.38.

Table M: Cam Brake Lubrication Intervals and Specifications

| Brake Component | Specification | Schedule | Procedure |
|---|---|---|---|
| Camshaft Bushings | Multi-Purpose Chassis Grease, 6% 12-hydroxy lithium stearate grease, NLGI Grade 1, Meritor specification O-617-A or equivalent Multi-Purpose Chassis Grease, 8% 12-hydroxy lithium stearate grease, NLGI Grade 2, Meritor specification O-617-B or equivalent | Lubricate at initial 30,000 miles (48 280 km). Thereafter, lubricate every 50,000 miles (80 467 km) or once a year, whichever comes first. For severe duty, lubricate more often. Frequency is determined by monitoring the condition of the grease. | Through the fitting on the bracket or spider until new grease flows from the inboard seal. |
| Brake Spider (Wedge Brakes Only) | Multi-Purpose Chassis Grease, 6% 12-hydroxy lithium stearate grease, NLGI Grade 1, Meritor specification O-617-A or equivalent Multi-Purpose Chassis Grease, 8% 12-hydroxy lithium stearate grease, NLGI Grade 2, Meritor specification O-617-B or equivalent | When necessary or when the brake is disassembled. | To areas that touch the brake shoes. |
| Camshaft Splines | Metallic-base, temperature resistant anti-seize compound, Meritor specification O-637 or equivalent | When necessary or when the brake is disassembled. | To all areas. |
| Anchor Pins | Anchor pin grease, non-melting grease with Bentone thickeners, NLGI Grade 1, Meritor specification O-616-A, O-617-B or equivalent | When necessary or when the brake is disassembled. | Through the fitting where the pins touch the brake shoes. |
| Shoe Rollers | Multi-Purpose Chassis Grease, 6% 12-hydroxy lithium stearate grease, NLGI Grade 1, Meritor specification O-617-A or equivalent Multi-Purpose Chassis Grease, 8% 12-hydroxy lithium stearate grease, NLGI Grade 2, Meritor specification O-617-B or equivalent | When necessary or when the brake is disassembled. | To roller pins at areas where the pins touch the brake shoes. Do not apply lubricant onto the part of the roller that touches the cam head. |
| ArvinMeritor Automatic Slack Adjusters* | Clay-base, non-melting grease with Bentone thickeners, NLGI Grade 1, Meritor specification O-616-A or equivalent Lithium-base, NLGI Grade 1 or 2, Meritor specification O-692 or equivalent Synthetic oil, clay-base, NLGI Grade 2, Meritor specification O-645 or equivalent | Whichever of the following is most frequent: <ul style="list-style-type: none"> • Every 6 months • Four times during the life of the linings Always inspect and lubricate the automatic slack adjuster when the brakes are relined. | Through the fitting until new grease purges from around the inboard camshaft splines and from the pawl assembly. |

*For non-Meritor automatic slack adjusters, refer to the vehicle manufacturer's instructions for maintenance intervals and specifications.

2 Bus and Coach

Table N: T Series Parking Brake Lubricant Specifications

| Description | Lubricant Specification |
|--------------------|--|
| Camshaft Bushings | Multi-purpose chassis grease, 6% 12-hydroxy lithium stearate grease, NLGI Grade 1, Meritor specification O-617-A or equivalent |
| Shoe Rollers | Multi-purpose chassis grease, 8% 12-hydroxy lithium stearate grease, NLGI Grade 2, Meritor specification O-617-B or equivalent |
| Anchor Pin | Anchor pin grease, non-melting grease with Bentone thickeners, NLGI Grade 2, Meritor specification O-616 or equivalent |
| Camshaft Splines | Metallic-base, temperature resistant anti-seize compound, Meritor specification O-637 or equivalent |

Stopmaster[®] Wedge Brakes

Lubricate the Stopmaster[®] brake every six months or 100,000 miles (161 000 km).

The grease used in Meritor Stopmaster[®] brakes must be NLGI Grade 1 or equivalent. The grease must keep its lubrication qualities under high temperatures. The grease must be smooth and contain no fillers or abrasives. The grease must have a resistance to water and corrosion. The grease must remain soft under normal parking storage conditions so that the brakes can be applied and released.

If the operating temperatures are down to -40°F (-40°C), use the following lubricants or their equivalent.

- Special Brake Grease, Meritor specification O-616-A
- Texaco Thermotex EP 1
- Texaco Hytherm EP 1
- Shell Darina 1
- Aral Aralub 3837

If the operating temperatures go below -40°F (-40°C), use the following lubricants or their equivalent.

- Special Low Temperature Brake Grease, Meritor specification O-645
- Mobilgrease 28
- Mobilgrease 32

Hazard Alert Messages

Read and observe all Warning and Caution hazard alert messages in this publication. They provide information that can help prevent serious personal injury, damage to components, or both.

⚠ WARNING

To prevent serious eye injury, always wear safe eye protection when you perform vehicle maintenance or service.

Technical Publications

How to Obtain Additional Maintenance and Service Information

Refer to the publications in Table O. To obtain these publications, refer to the Service Notes page on the front inside cover of this manual.

Table O: Publications

| Model | Manual |
|-------------------------|------------------------|
| Clutches | Maintenance Manual 25A |
| Clutch Failure Analysis | TP-9494 |

Description

Meritor clutches are primarily used on Class 6 to Class 8 series vehicles. The clutches are available in 14-inch manual adjust, 15-1/2-inch manual adjust and 15-1/2-inch AutoJust™ models. The clutches are available in an eight-hole installation pattern. Figure 3.1, Figure 3.2 and Figure 3.3.

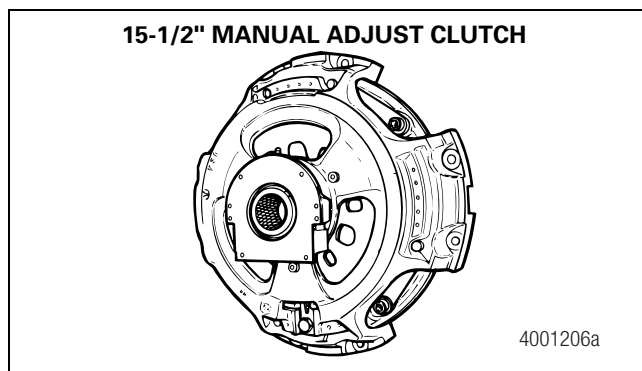

Figure 3.2

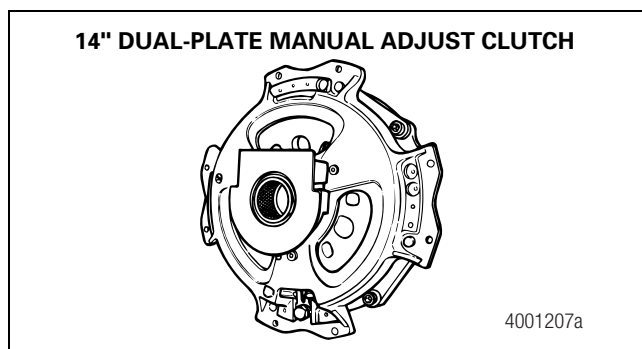

Figure 3.3

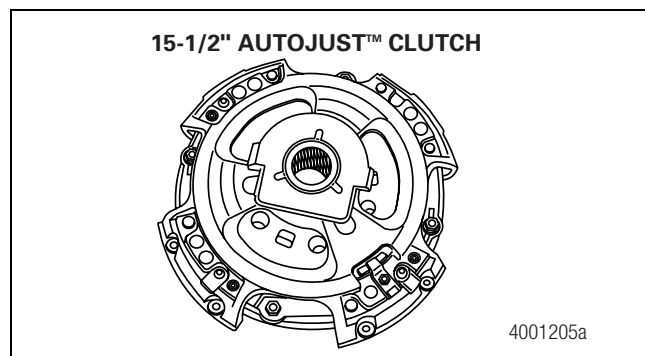

Figure 3.1

3 Clutches

Identification

To identify a clutch, refer to the identification and serial numbers located on the front of the clutch cover. Refer to these numbers when you replace parts. Use only the specified parts.

- **For clutch models manufactured on or before May 1999:**
Refer to the identification tag and serial number tag attached to the clutch cover. Figure 3.4.

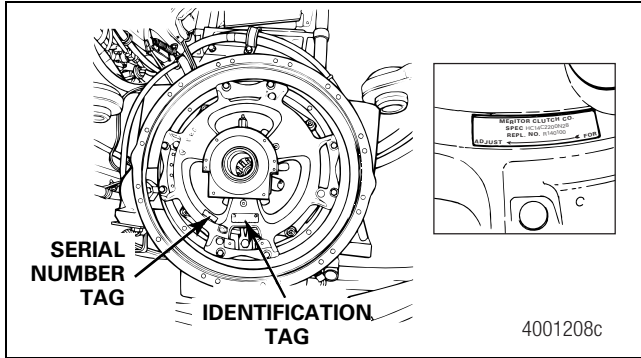

Figure 3.4

- **For clutch models manufactured on or after May 1999:**
Refer to the identification and serial numbers etched on the clutch housing. Figure 3.5.

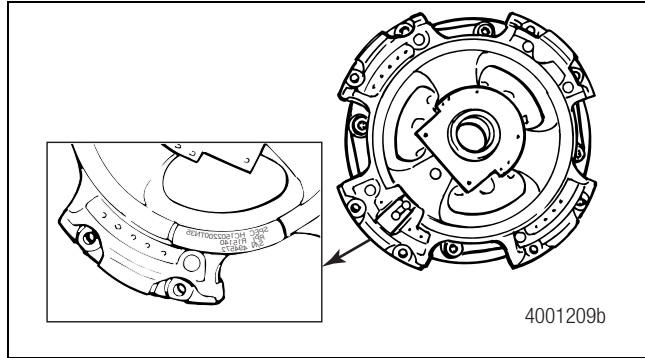

Figure 3.5

Model Nomenclature

Refer to Figure 3.6 for an explanation of the original clutch specification number. Refer to Figure 3.7 for an explanation of the replacement clutch assembly part number.

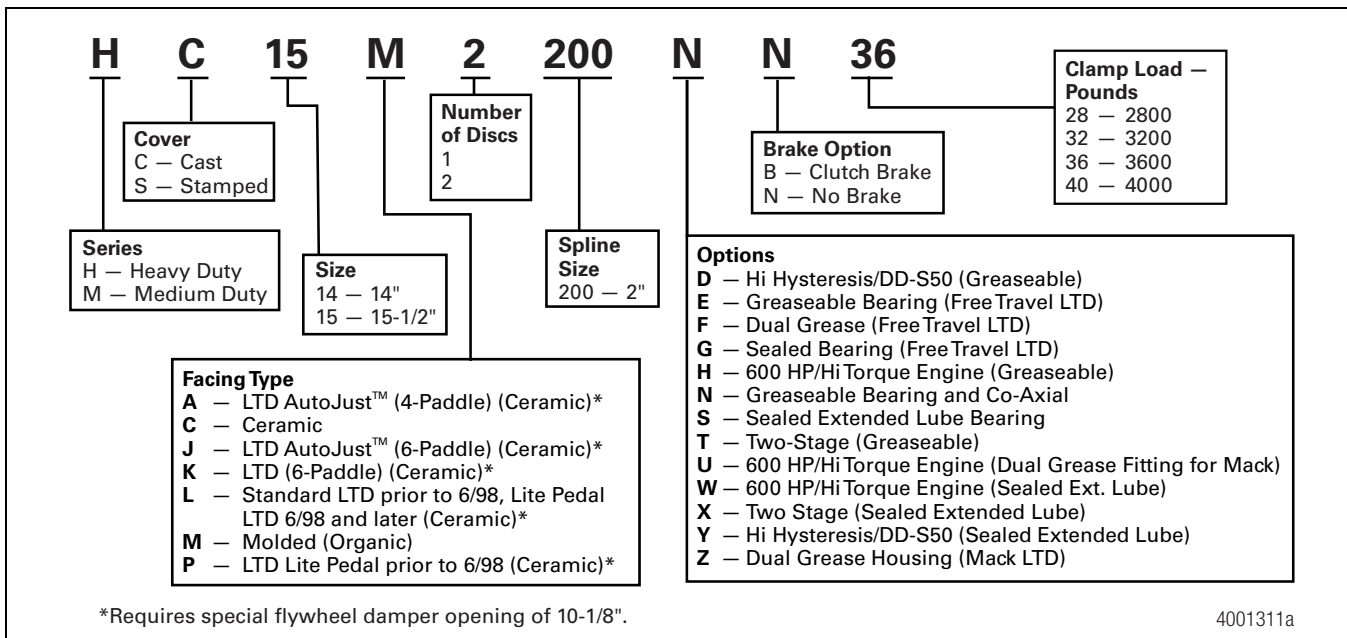

Figure 3.6

4001311a

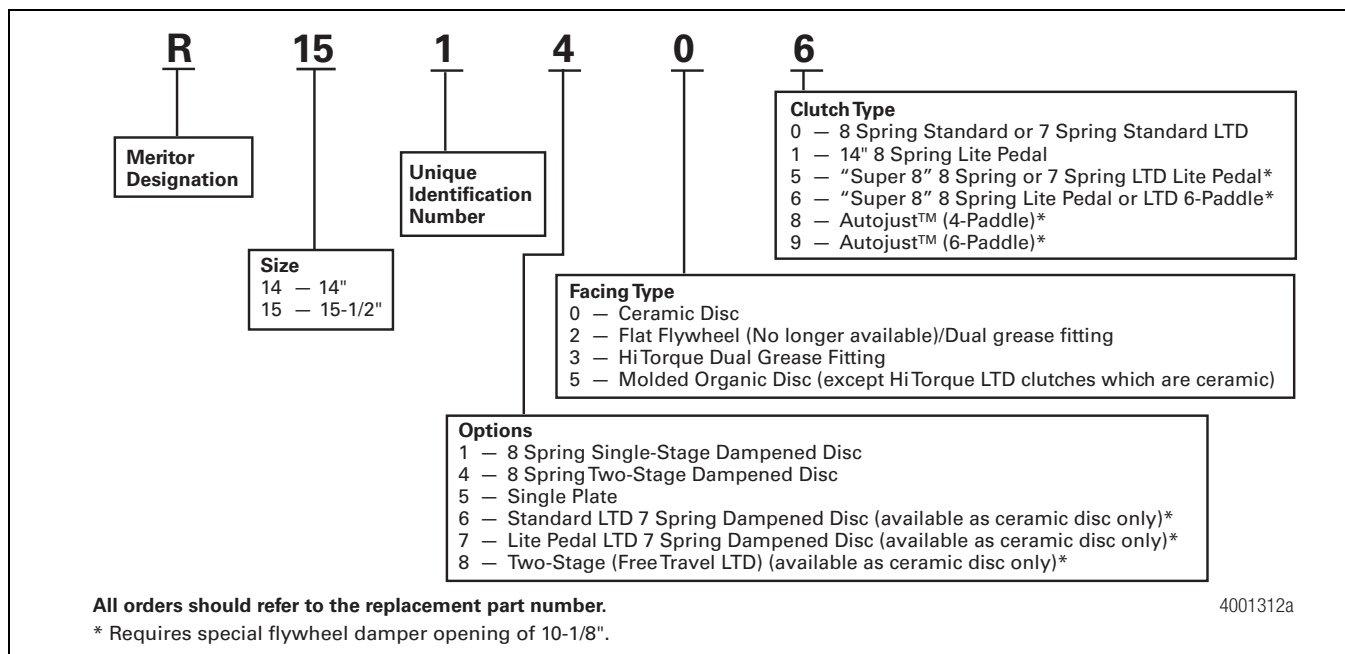

Figure 3.7

Inspection

When to Inspect the Clutch

Inspect the clutch when any of the following occurs.

- As required by the maintenance schedule of the vehicle manufacturer
- When any part of the clutch system is serviced
- When the clutch pedal free travel is less than 1/2-inch (13 mm) or more than 1-1/2-inches (38 mm)

Clutch Linkage

The clutch linkage must be inspected carefully. The clutch will not operate correctly if the linkage is worn or damaged. Inspect the linkage according to the following procedures. Figure 3.8.

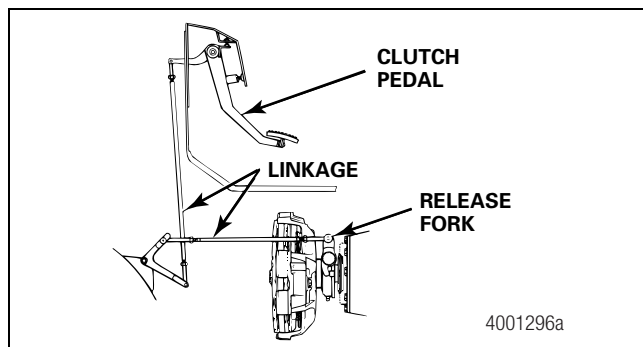

Figure 3.8

1. **The operation of the linkage.** Push down on the clutch pedal and have another person check the release fork for movement. The smallest movement of the clutch pedal must cause movement at the release fork.
 - **If the release fork does not move when the clutch pedal moves:** Find and service the cause of the free play condition.
2. **The condition of the linkage operation.** The linkage must move if the pedal is actuated. The linkage must not be obstructed. Every pivot point operates freely. The linkage must not be loose at any point.
 - **If the linkage does not operate freely:** Find and service the cause of the condition.
3. **The condition of all parts of the linkage.** Inspect the clutch linkage. The pedal, springs, brackets, bushings, shafts, clevis pins, levers, cables and rods must not be worn or damaged. If a hydraulic system is used, verify that the system is not leaking and that the reservoir is filled to the specified level. Replace any parts that are missing or damaged. Do not straighten any damaged parts.
4. **Lubrication.** Every pivot point in the linkage must be lubricated. Use the lubricant specified by the vehicle manufacturer. Refer to the lubricant specifications listed in this section.

3 Clutches

Internal Parts of the Clutch

Remove the capscrews from the inspection cover. Remove the cover. Inspect the internal parts of the clutch according to the following procedure.

⚠ CAUTION

The inspection cover on the clutch housing must be used. If an inspection cover is not used, dirt and contaminants can get into the clutch housing and damage the clutch.

1. **Release Bearing Clearance — Non-Synchronized Transmission.** Adjust the release bearing clearance if the distance between the release bearing and the clutch brake is not 0.500-0.560-inch (12.7-14.2 mm). Refer to Maintenance Manual 25A, Clutches. To obtain this publication, refer to the Service Notes page on the front inside cover of this manual. Figure 3.9.

NOTE: A 1/2-inch gauge tool, SP2033, is available from Snap-on Tools. Refer to the Table U.

2. **Release Bearing Clearance.** The AutoJust™ clutch clearance should be 0.500-0.560-inch (12.7-14.2 mm). Figure 3.10.
3. **Release Fork Clearance.** Verify that there is a distance of 0.105-0.145-inch (2.67-3.68 mm) between the fork and the boss of the release bearing. If the distance is not 1/8-inch (3 mm), adjust the linkage. Figure 3.11.

NOTE: A 1/8-inch gauge tool, SP2034, is available from Snap-on Tools. Refer to Table U.

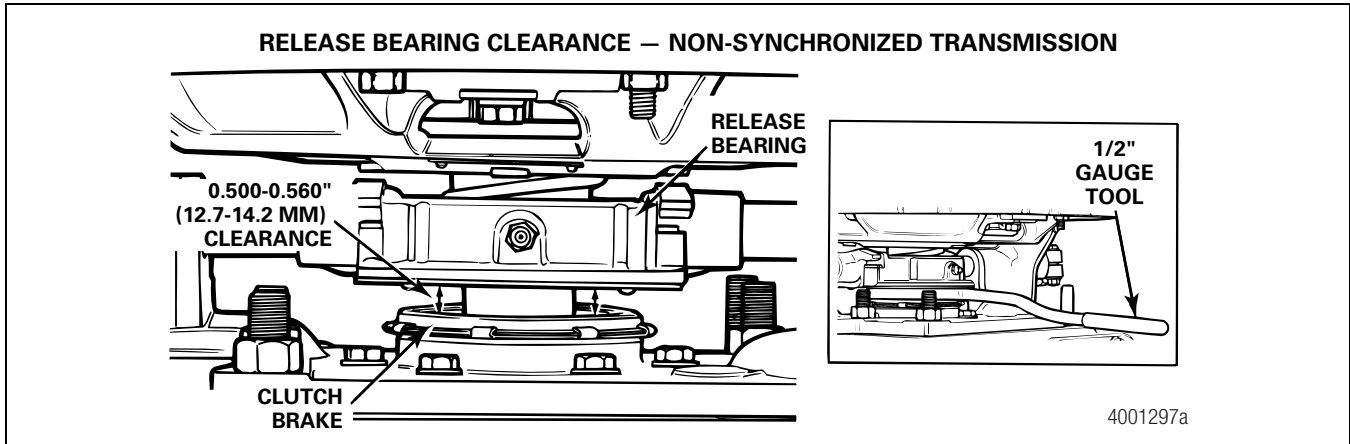

Figure 3.9

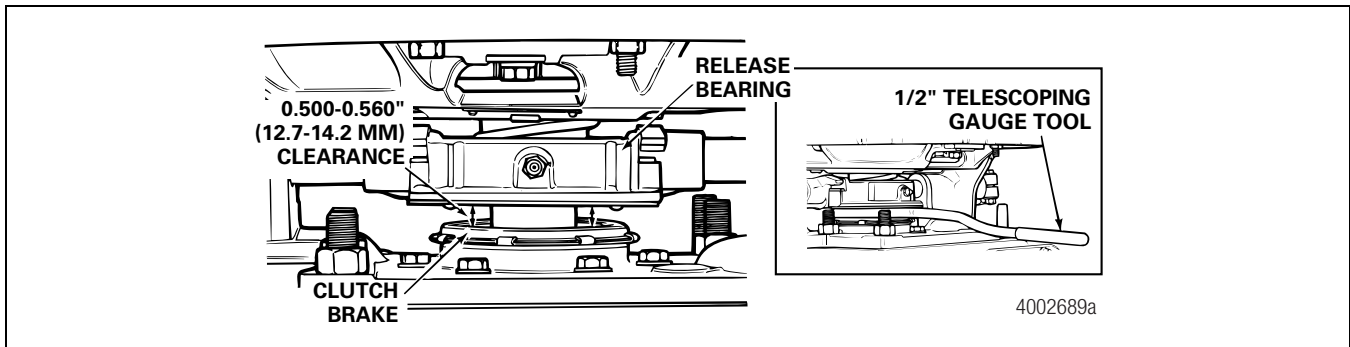

Figure 3.10

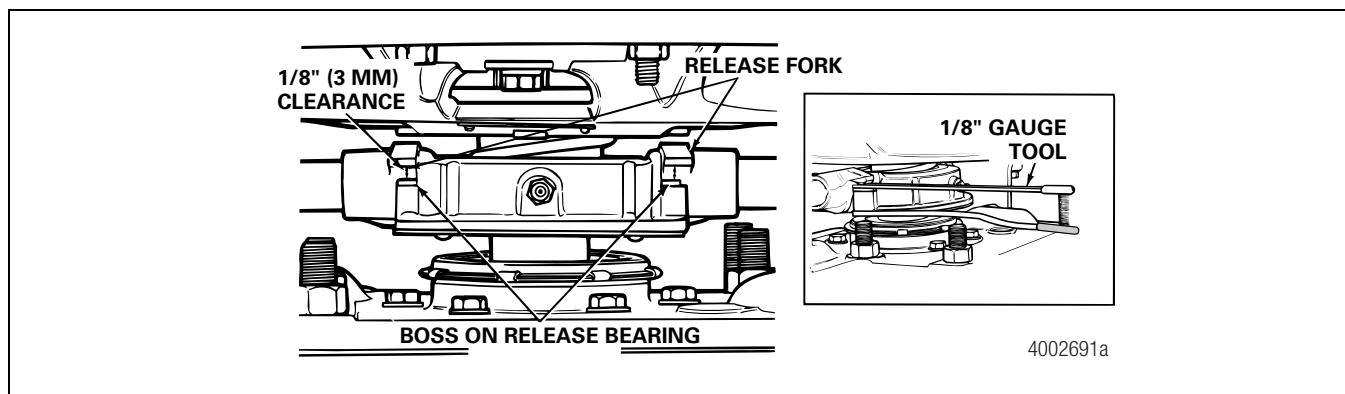

Figure 3.11

4. The AutoJust™ sensor bolt clearance between the bolt head and flange should be 0.55-inch (14 mm) minimum.
5. **Release Fork Condition.** Remove and replace the release fork if the tips are worn or damaged.
6. **Release Bearing Condition.** Replace the complete clutch assembly if the bearing is worn or damaged. The bearing must be lubricated.
7. **Transmission Input Shaft Condition.** If the splines are worn or damaged, replace the input shaft.
8. **Transmission Input Bearing Retainer.** Inspect the input bearing retainer on the transmission. Check the area where the clutch brake touches the retainer. Replace it if worn.
5. If the release bearing is equipped with a lube tube, grease must be coming out of the bearing housing, which ensures that lubricant is reaching the bearing. Verify that the lube tube is secure and not damaged.
6. Use the same procedure for extended lubrication clutches, at the same specified interval.
7. Install the inspection cover. Figure 3.12.

Lubrication

Release Bearing

⚠ CAUTION

The inspection cover on the clutch housing must be used. If an inspection cover is not used, dirt and contaminants will enter the clutch housing and damage the clutch.

1. Remove the inspection cover on the clutch housing.
2. Clean all grease fittings prior to lubrication.
3. Correctly lubricate the release bearing. Apply grease to the grease fitting on the release bearing until a small amount of grease comes out of the bearing housing. Do not overgrease.
4. Apply grease to the release fork tips where they contact the bearing housing. Also apply grease to the exposed transmission input shaft between the clutch bearing housing and the transmission input bearing retainer to lubricate the clutch release sleeve bushing.

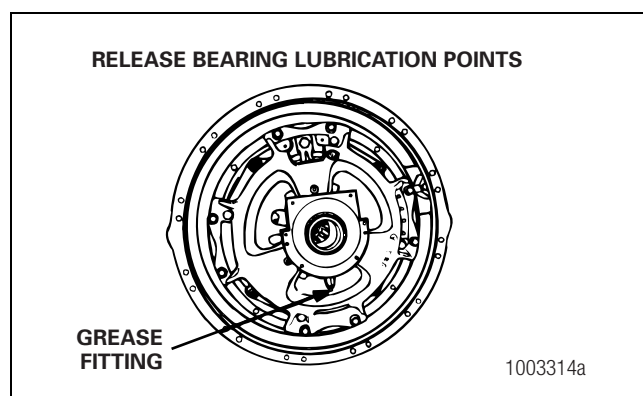

Figure 3.12

3 Clutches

Clutch Housing

1. Clean all grease fittings prior to lubrication.
2. Grease the release fork cross shaft by applying grease to each fitting on the clutch housing until a small amount of grease purges out. Use the specified lubricant at the recommended interval. Refer to the lubricant specifications and maintenance intervals of the vehicle manufacturer. Figure 3.13.

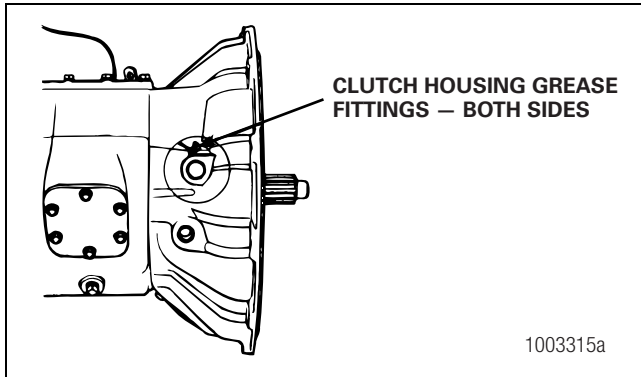

Figure 3.13

Linkage

NOTE: Some vehicle manufacturers may use “lubed-for-life” ball joints in the clutch linkage. Refer to the vehicle manufacturer’s instructions.

Lubricate each pivot point on the linkage according to the vehicle manufacturer’s procedure. Use the specified lubricant at the recommended interval. Refer to the lubricant specifications and maintenance intervals in the tables in this section. Figure 3.14.

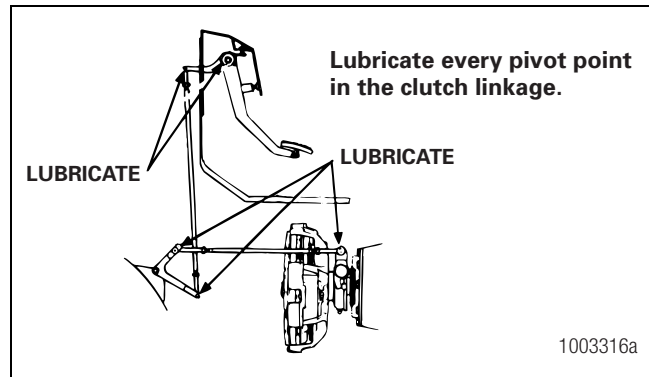

Figure 3.14

Lubrication Intervals and Specifications

Table P: Greasing Intervals and Specifications

| Component | Greasing Interval | Grease | Meritor Specification | NLGI Grade | Grease Description | Outside Temperature |
|-------------------------------------|---|---|-----------------------|------------|--------------------|-----------------------|
| Standard Greaseable Release Bearing | Approximately 15,000 miles (24 140 km) or at each engine oil change | High Temperature Multi-Purpose Wheel Bearing Grease | 0-661 | 3 | Lithium Complex | Down to -40°F (-40°C) |
| Extended Lube Release Bearing | Approximately 100,000 miles (16 934 km) | | | | | |
| Cross Shaft | 1 | 2 | — | — | — | — |
| Clutch Linkage | 1 | 2 | — | — | — | — |

¹ Use the interval specified by the vehicle manufacturer or the fleet, but verify that the release bearing is greased once per month.

² Use the grease specified by the vehicle manufacturer.

Table Q: Approved Lubricants

| Lubricant | Recommendation |
|-----------------------|--|
| Clutch Bearing Grease | Exxon Unirex N Grade 3 (NLGI Grade 3, Lithium Complex) |

Troubleshooting

Before troubleshooting the clutch, verify the following. Once these conditions are verified, refer to Table R, Table S and Table T to troubleshoot the clutch.

1. The engine is operating correctly.
2. The engine mounts are in good condition.
3. The driveline angles of the engine, transmission, driveshaft and rear axle are correct.
4. The inspection cover is installed on the clutch housing.

Operating Conditions

Table R: Operating Conditions Diagnostic Table

| Condition | Possible Cause | Correction |
|--|--|--|
| Clutch does not release or does not release completely. | Release bearing clearance needs adjustment. | Adjust release bearing clearance. |
| | Clutch linkage needs adjustment. | Adjust clutch linkage. |
| | Worn or damaged linkage. | Lubricate linkage. Verify that the linkage is not loose. If condition still exists, replace linkage. |
| | Worn or damaged release bearing. | Lubricate release bearing. If condition still exists, replace release bearing. |
| | Worn or damaged splines on input shaft. | Replace input shaft. |
| | Bell housing loose. | Tighten fasteners to specified torque. If necessary, replace fasteners. |
| | Center plate binding. | 14-inch clutch: Inspect drive pins in flywheel housing and slots in center plate. 15-1/2-inch clutch: Inspect tabs on center plate and slots in cover. Service as necessary. |
| | Damaged hub in clutch discs. | Replace discs. |
| | Damaged pilot bearing. | Replace pilot bearing. |
| Clutch pedal is hard to operate. | Excessively worn contact pads on release bearing. | Replace clutch assembly. Verify that the clutch is correctly adjusted. |
| | Tight or stiff pivots in clutch linkage. | Lubricate linkage. If condition still exists, replace linkage. |
| | Worn or damaged clutch components. | Replace clutch assembly. |
| | Worn or damaged pedal shaft or cross shaft bushings. | Repair or replace as necessary. |

3 Clutches

Table R: Operating Conditions Diagnostic Table

| Condition | Possible Cause | Correction |
|--|---|--|
| Clutch slips out of engagement. | Driver keeps foot on clutch pedal. | Use correct vehicle operating procedure. |
| | Clutch release bearing clearance needs adjustment. | Adjust release bearing clearance. |
| | Clutch linkage needs adjustment. | Adjust clutch linkage. |
| | Worn or damaged clutch components. | Replace clutch assembly. |
| | Worn or damaged facings. | Replace clutch discs. |
| | Oil or grease on facings. | Replace clutch assembly. |
| | Worn or damaged flywheel. | Service flywheel as necessary. Refer to the procedure of engine or vehicle manufacturer. |
| Clutch is noisy. | Clutch has inadequate torque capacity. | Replace with clutch rated for maximum engine torque. |
| | Linkage worn/excessive clearances. | Replace worn components. |
| | Worn or damaged release bearing. | Lubricate release bearing. If condition still exists, replace clutch assembly. |
| | Bell housing loose. | Tighten fasteners to specified torque. If necessary, replace fasteners. |
| | Transmission neutral idle rattle. | Verify correct clutch is being used. |
| | Damaged hub or broken co-axial springs in clutch discs. | Replace clutch assembly. |
| | Facings damaged. | Replace clutch assembly. |
| Clutch vibrates. | Damaged pilot bearing. | Replace pilot bearing. |
| | Worn or damaged splines on input shaft. | Replace input shaft. |
| | Clutch/flywheel out-of-balance. | Remove, check balance, or try reorienting clutch to flywheel. If condition still exists, replace clutch assembly. |
| | Worn or damaged splines in hub of clutch discs. | Replace clutch assembly. |
| | Loose flywheel. | Tighten fasteners to specified torque. If necessary, replace fasteners. Check flywheel mounting surface for damage, replace if necessary. |
| | | |
| | Transmission-to-engine misalignment. | Check runout of flywheel and bell housing. Verify that the transmission-to-engine alignment is correct. Refer to vehicle manufacturer's procedure. |

Components

Table S: Components Diagnostic Table

| Condition | Possible Cause | Correction |
|---|---|---|
| Broken tabs on clutch brake | Release bearing clearance needs adjustment. | Adjust release bearing clearance. |
| | Clutch linkage needs adjustment. | Adjust clutch linkage. |
| | Driver engages clutch brake incorrectly while vehicle is moving. | Use correct driving procedures. |
| Worn or damaged release bearing housing | Driver keeps foot on clutch pedal. | Use correct vehicle operating procedures. |
| | Free travel not adjusted correctly. | Adjust free travel correctly. |
| Worn bosses on release bearing housing | Damaged or out-of-adjustment linkage. | Lubricate and adjust linkage. Inspect linkage for wear or damage. |
| | Release fork binding. | Lubricate shaft of release fork. If fork does not move freely, replace shaft and fork assembly. |
| | Free travel out-of-adjustment. | Adjust free travel to specification. |
| Worn or damaged input shaft splines | Transmission not aligned. | Verify that driveline angles are correct. |
| | Incorrect transmission installation procedures. | Install transmission correctly. |
| | Damaged hubs in clutch discs. | Replace clutch assembly. |
| | Worn or damaged pilot bearing. | Replace pilot bearing. |
| Pressure plate cracked or damaged by heat | Driver engages clutch while vehicle is coasting to create shock load. | Use correct vehicle operating procedures. |
| | Driver uses clutch as a brake to hold vehicle on a grade. | Use correct vehicle operating procedures. |
| | Free travel not adjusted correctly. | Adjust free travel to specification. |
| | Oil or grease on facings. | Replace clutch assembly. |
| | Driver slips clutch excessively during engagement. | Use correct vehicle operating procedures. |
| | Too much dirt in bell housing. | Remove dirt from bell housing. Service as necessary. Verify that inspection cover is installed. |
| Adjusting ring does not move | Worn or damaged adjusting ring. | Replace clutch assembly. |
| | Incorrect transmission installation procedures. | Replace clutch assembly. Install transmission correctly. |
| Warped hub in clutch disc | Incorrect transmission installation procedures. | Install transmission correctly. |
| Hub separates from disc | Clutch housing loose. | Tighten clutch housing to specified torque. If necessary, replace fasteners. |
| | Shock loading. | Use correct vehicle operating procedures. |
| | Shock loading. | Use correct vehicle operating procedures. |
| Co-axial springs separate from disc | Shock loading. | Use correct vehicle operating procedures. |
| Heat damage on disc | Driver keeps foot on clutch pedal or slips clutch. | Use correct vehicle operating procedures. |
| | Clutch does not engage or disengage completely. | Refer to Table R. |
| | Free travel not adjusted correctly. | Adjust free travel correctly. |
| | Worn or damaged diaphragm spring. | Replace clutch assembly. |
| | Grease or oil on facings. | Replace clutch assembly. |
| Linings separate from discs | Facings worn past specified dimension. | Replace clutch assembly. |
| Cracked or damaged center plate | Driver does not start vehicle in correct gear. | Use correct vehicle operating procedures. |
| | Driver uses clutch as a brake to hold vehicle on a grade. | Use correct vehicle operating procedures. |
| | Driver slips clutch excessively during engagement. | Use correct vehicle operating procedures. |

3 Clutches

WARNING

Operate the vehicle according to the vehicle manufacturer's procedure. Do not coast downhill with the transmission in gear and the clutch released. If the vehicle coasts downhill with the transmission in gear and the clutch released, the facings can separate from the disc and cause serious personal injury and damage.

Table T: Driver Procedures Diagnostic Table

| Driver Procedures | Results |
|---|--|
| Driver keeps foot on clutch pedal. | Clutch is always partially disengaged. Results in too much slipping and causes clutch to overheat. Overheating causes damage to the linings, pressure plate, center plate and flywheel. Release bearing is also damaged. |
| Driver uses clutch as a brake. | Promotes faster wear of linings on disc and causes clutch to overheat. |
| Driver shifts transmission before minimum shift speed. | Places a severe shock on the drivetrain. Will damage disc hub assemblies. |
| Driver coasts downhill with the transmission in gear and the clutch released. | Will place too many RPMs on input shaft due to rear axle driving transmission. Can cause facings to separate from disc. |
| Driver applies clutch while coasting downhill. | Places a severe shock load on the drivetrain. Will damage disc and hub assemblies, as well as the entire powertrain. |
| Driver applies clutch brake while shifting when vehicle is moving. | Damages clutch brake. Damaged clutch brake results in gear clash or noise when engaging first or reverse gears. |

Special Tools

NOTE: To obtain these tools, refer to the Service Notes page on the front inside cover of this manual.

Table U: Special Maintenance Tools

| Description | SPX Kent-Moore Tool Number | Owatonna Tool Number | Snap-on Tool Number | Meritor Tool Number |
|---|-------------------------------|-------------------------|------------------------|------------------------|
| Clutch Adjustment Tool | J 36216 | 7028 | GA454 | R170000 |
| Pedal Pusher | J 39610 | — | — | — |
| 1/2" Gauge Tool (Non-Synchronized Transmission) | — | — | SP2003 | — |
| 1/8" Gauge Tool | — | — | SP2034 | — |

Hazard Alert Messages

Read and observe all Warning and Caution hazard alert messages in this publication. They provide information that can help prevent serious personal injury, damage to components, or both.

⚠ WARNING

To prevent serious eye injury, always wear safe eye protection when you perform vehicle maintenance or service.

Technical Publications

How to Obtain Additional Maintenance and Service Information

Refer to the publications in Table V. To obtain these publications, refer to the Service Notes page on the front inside cover of this manual.

Table V: Publications

| Model | Manual |
|--------------------------|--------------------------------------|
| Drivelines | Maintenance Manual MM-0998, MM-96147 |
| Driveline I.D. Gauge Kit | SP-87101B |
| Drivelines | Failure Analysis Manual TP-0445 |

Description

RPL Series Permalube™ (Non-Greaseable)

The Meritor RPL Series Permalube™ non-greaseable driveline is permanently lubricated and sealed at the factory and does not require lubricants. Arrows on the wing bushings help you to correctly install the universal joint. Figure 4.1.

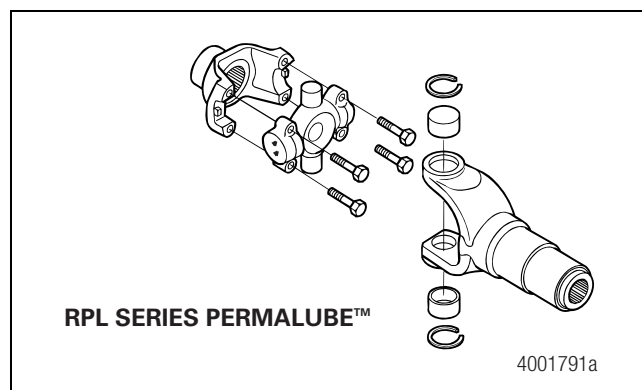

Figure 4.1

Wing-Style Permalube™

The Meritor Wing-Style Permalube™ driveline requires lubrication of the slip yoke splines only. Figure 4.2.

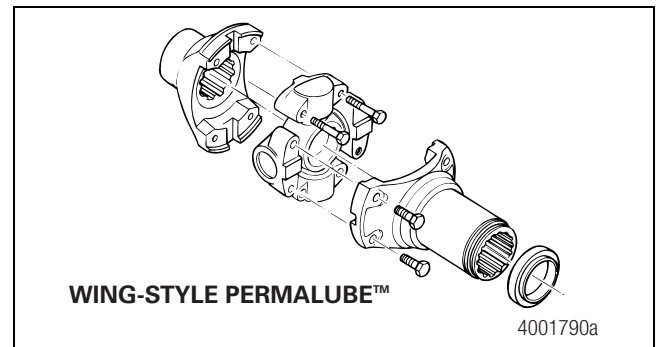

Figure 4.2

Full-Round, Easy Service™, Wing-Style and 155R Series (Greaseable)

Full-Round, Easy Service™, Wing-Style and 155R Series greaseable drivelines require periodic lubrication of the universal joints and slip yoke splines. Figure 4.3, Figure 4.4 and Figure 4.5.

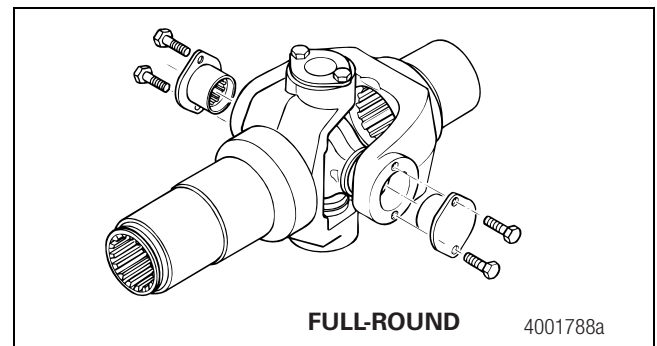

Figure 4.3

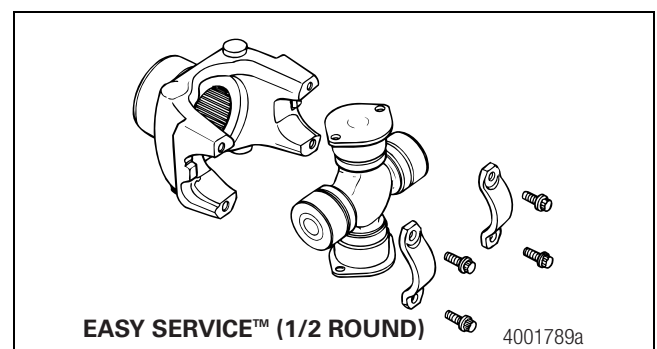

Figure 4.4

4 Drivelines

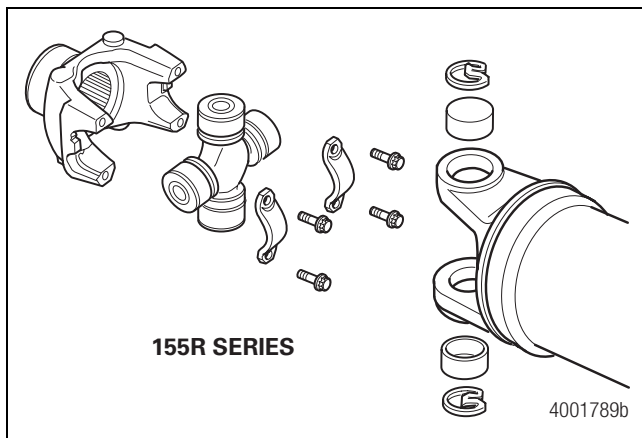

Figure 4.5

Identification

Meritor genuine driveline components are identified by the following markings on the component.

- Logo stamped on the part
- Balance bosses
- Forging part number which identifies the driveline series

Table W: Drivelines

| Meritor Driveline Series | |
|--------------------------|------|
| 155R | 58WB |
| 16N | 62N |
| 17N | 72N |
| 176N | 82N |
| 18N | 85WB |
| 25W* | 92N |
| 20W* | |

* RPL25 and RPL20 do not follow the above convention and utilize their own unique numbering system.

Inspection

Driveline

⚠ WARNING

Check end yoke retaining nuts and bolts for looseness. Tighten loose fasteners to specification. Check the input and output shaft splines for wear and damage. Replace worn or damaged splines. Check for loose, missing or damaged driveline fasteners and parts. Tighten loose fasteners, and replace damaged and missing parts. Loose, damaged or missing parts can cause the driveline to separate from the vehicle. Serious personal injury and damage to components can result.

Only service a driveline when the engine is OFF. A rotating driveline can cause serious personal injury.

Park the vehicle on a level surface. Block the wheels to prevent the vehicle from moving. Support the vehicle with safety stands. Do not work under a vehicle supported only by jacks. Jacks can slip and fall over. Serious personal injury and damage to components can result.

1. Park the vehicle on a level surface. Block the wheels to keep the vehicle from moving. Raise the vehicle so that the area you will service is off the ground.
2. Inspect the driveline at regular intervals. Loose end yokes, excessive radial movement, slip spline radial movement, bent driveline tubing or missing plugs in the slip yoke can damage universal joints and bearings.
3. Check the output and input end yokes on both the transmission and axle for axial looseness. Refer to the axle or transmission manufacturer's service instructions.
 - **If the output and input end yokes are loose:** Disconnect the driveline. Tighten the end yoke retaining nut to the correct specification. Refer to the axle or transmission manufacturer's service instructions.
4. Inspect for worn universal joints. Apply vertical force of about 50 pounds (22.7 kg) to the driveline near the universal joints.
 - **If movement is greater than 0.006-inch (0.152 mm):** Replace the universal joint.

5. Use a dial indicator to examine the slip yoke spline for excessive radial movement. Radial movement between the slip yoke and the tube shaft must not exceed 0.017-inches (0.432 mm).
 - **If the radial movement exceeds 0.017-inch (0.432 mm):** Replace the slip yoke and the tube shaft.
6. Inspect the driveline for damaged or bent tubing. Carefully remove contaminants, such as mud and road debris.

End Yokes

Perform the following procedures before you lubricate universal joints or slip yokes. If you lubricate these components before you inspect them, lubricant can cover wear, damage and looseness.

1. Do not lubricate components. Inspect all input and output end yoke retaining nuts and bolts for gaps between mating surfaces.
 - **If gaps are present:** Refer to the transmission, axle or transfer case manufacturer's service instructions.
2. Check the output and input end yokes on both the axle and transmission for axial looseness using the following procedure. Also refer to the axle or transmission manufacturer's service instructions.
 - A. Hold the end yoke with both hands.
 - B. Move the end yoke UP-AND-DOWN and SIDE-TO-SIDE. There shouldn't be any movement where the yoke connects to the input and output shafts. Figure 4.6.
 - **If the input and output end yokes are loose:** Disconnect the driveline. Tighten the end yoke retaining nut or bolt to the correct specification. Refer to the axle or transmission manufacturer for correct inspection and replacement procedures.
 - **If the input and output end yokes are not loose, check that the transmission output shaft and axle input shaft splines aren't loose at the end yoke:** Hold the yoke with one hand and rotate it LEFT-TO-RIGHT while you check end play for radial looseness. Figure 4.6.
 - **If you find excessive radial looseness:** Replace the end yoke, or input or output shafts, as necessary.

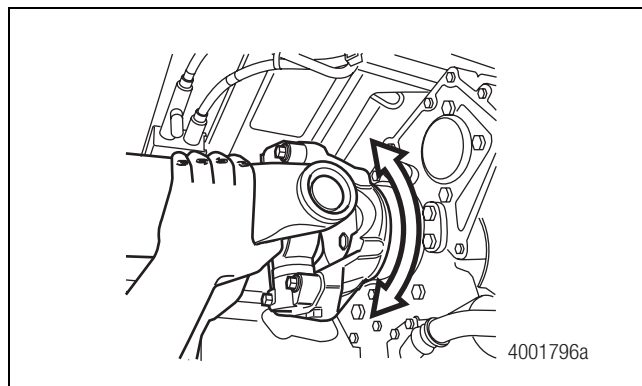

Figure 4.6

3. Inspect for worn, damaged, missing and loose parts. Replace as required.

⚠ WARNING

Use a fine-tooth file or an emery cloth to remove raised metal or fretting from yoke cross hole surfaces. Take care not to remove an excessive amount of metal. These conditions can damage the cross and bearing and cause the driveline to separate from the vehicle. Serious personal injury and damage to components can result.

4. Inspect all end yoke cross hole surfaces and bolt hole threads for damage. Remove raised metal or fretting with a fine-tooth file or emery cloth. Figure 4.7.
 - **If bolt hole threads are damaged:** Replace the yoke.

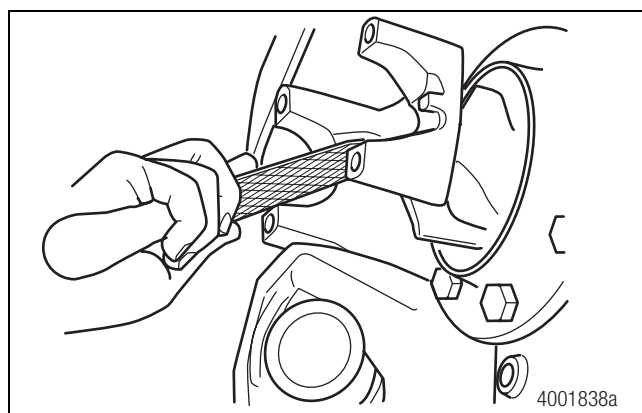

Figure 4.7

4 Drivelines

Universal Joints

⚠ WARNING

Excessive looseness across the ends of universal joint bearing cup assemblies can cause imbalance or vibration in the driveline assembly. Imbalance or vibration can cause component wear, which can result in separation of the driveline from the vehicle. Serious personal injury and damage to components can result.

1. Use the following procedure to check for looseness across the ends of the universal joint bearing cup assemblies and trunnions.
 - A. Hold the INBOARD yoke on the driveline with both hands.
 - B. Try to move the yoke UP-AND-DOWN and SIDE-TO-SIDE by applying at least 50 lb-ft (222.5 N•m) of force to the driveline near the universal joints. Figure 4.8. **ⓘ**
 - **If movement is greater than 0.006-inch (0.152 mm):** Replace the universal joint.
2. Inspect all universal joint kits in the driveline assembly.

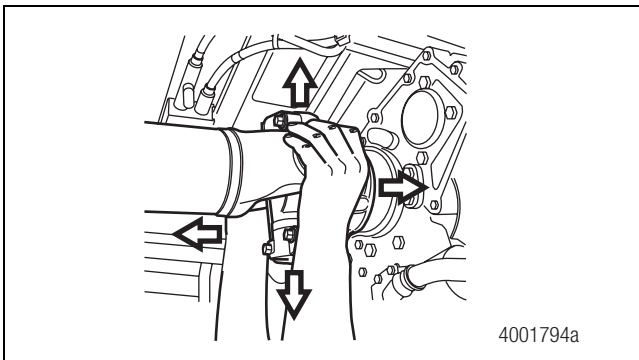

Figure 4.8

Greaseable Universal Joints

1. Check that all grease fittings are installed. Replace missing or damaged fittings. Tighten them to 6 lb-ft (8 N•m). Figure 4.9. **ⓘ**
2. Check for loose grease fittings. Tighten them to 6 lb-ft (8 N•m). **ⓘ**

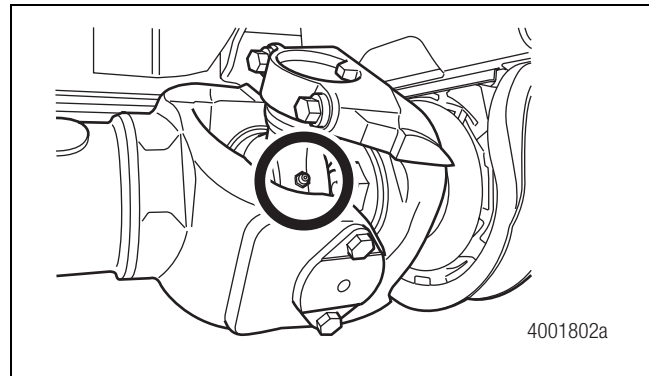

Figure 4.9

Center Bearings

1. Inspect all center bearing and end yoke midship nuts for gaps between the mating surfaces. Figure 4.10.
 - **If you can see gaps between the mating surfaces:** Disconnect the driveline. Tighten the coupling yoke retaining nut to 450-600 lb-ft (612-816 N•m). **ⓘ**

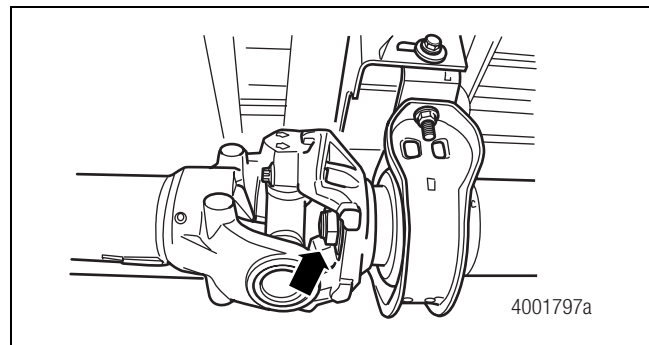

Figure 4.10

2. Inspect the center bearing bracket bolts for looseness. Figure 4.11.
 - **If the bolts are loose:** Verify that the bracket is aligned correctly before you tighten the bolts. Tighten the center bearing bracket bolts. Refer to the vehicle manufacturer's procedures for the correct torque specification.

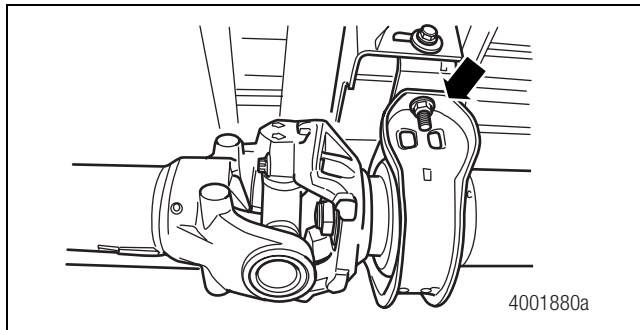

Figure 4.11

- Inspect the center bearing rubber cushion for damage. If equipped, check that the deflectors are not rubbing against the rubber cushion. Verify that the rubber cushion is correctly seated in the metal bracket.

- If any of these conditions are evident:** Replace the center bearing assembly.

Self-Aligning Center Bearings

A self-aligning center bearing accepts ± 5 degrees of angular misalignment. This helps to ensure that the hanger bearing is correctly aligned to the driveline under all operating conditions.

Use the same service procedures for a self-aligning center bearing as for a standard center bearing. You can identify a self-aligning center bearing by the bright gold color of the integral deflector.

Deflectors are integral to a self-aligning center bearing, so separate deflectors are not required.

Some vehicles manufactured after January 18, 2002, are equipped with self-aligning center bearings. Figure 4.12.

- If you replace a self-aligning center bearing on a vehicle manufactured after January 18, 2002:** You must install a new self-aligning center bearing. Do not install an original-design bearing.

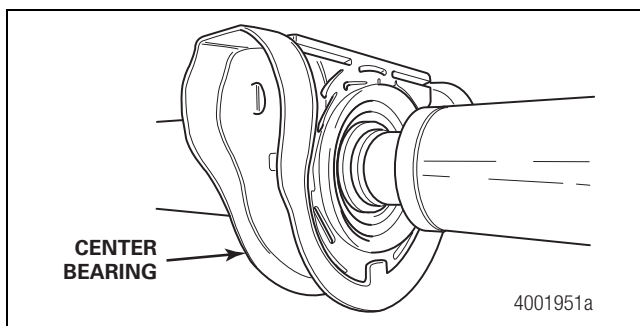

Figure 4.12

Slip Yoke

NOTE: Check a slip yoke for movement with the driveline installed and the vehicle on a level surface with its wheels on the ground.

- Check that the vehicle is on a level surface with its wheels on the ground. The driveline should be installed.
- Firmly mount a dial indicator with a magnetic base onto the slip yoke barrel next to the dust seal. Figure 4.13. You don't want the dial indicator to move when you check the slip yoke for looseness, or the measurement will not be correct.
- Extend the dial indicator arm from the base, so that it contacts the neck of the spline plug within 3/4-inch (19.05 mm) from the dust seal. Figure 4.13.

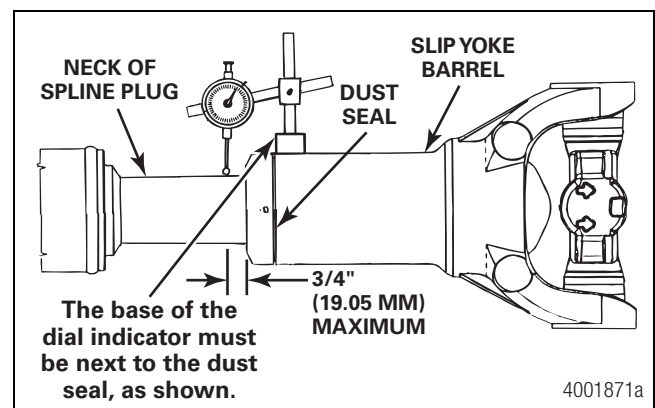

Figure 4.13

- With your hands near the center of the driveline, move the slip yoke UP-AND-DOWN. Check the dial indicator measurement. Movement between the spline plug and slip yoke must not exceed 0.017-inch (0.432 mm). Figure 4.14.
 - If movement exceeds 0.017-inch (0.432 mm):** Components are worn or damaged. Replace as required.

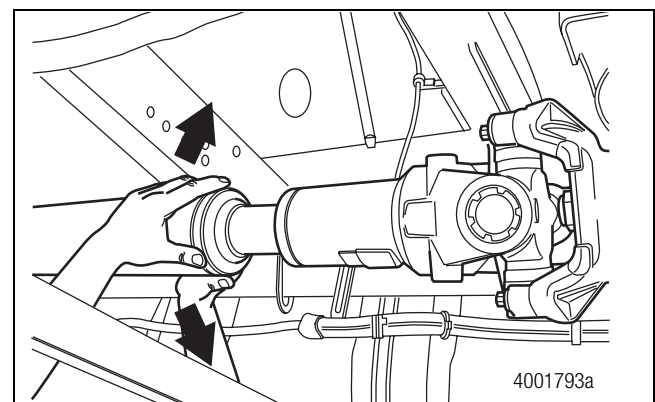

Figure 4.14

4 Drivelines

5. Inspect the driveline for damage or bent tubing.
 - **If the driveline is damaged or bent:** Replace the driveline.
6. If necessary, carefully remove mud or road debris from the driveline.
7. Inspect the slip yoke spline seal for grease leakage or seal damage.
8. Inspect for missing balance weights, damaged tubing or a missing welch plug at the slip yoke.

Universal Joint Capscrews

WARNING

Inspect RPL Series Permalube™ and Wing-Style Permalube™ drivelines for loose or missing capscrews and lock washers. Loose or missing fasteners can allow the driveline to separate from the vehicle. Serious personal injury and damage to components can result. If fasteners are loose or missing:

- **RPL Series Permalube™ drivelines:** Install new capscrews with Dri-Loc® patches.
- **Wing-Style Permalube™ drivelines:** Install new capscrews with Dri-Loc® patches and secure the capscrews with lock washers.

Meritor recommends that you inspect RPL Series Permalube™ bearing cup capscrews and Wing-Style capscrews and lock washers at initial inspection, or no more than 2,000 miles (3200 km).

RPL Series Permalube™ Driveline

1. Check that capscrews are installed on all universal joint positions. RPL Series Permalube™ capscrews and Wing-Style Permalube™ capscrews are not interchangeable.
 - **If the capscrews are missing:** Check for damage to the universal joint and yoke. Replace damaged parts and missing capscrews.
 - **If the capscrews are loose:** Remove and discard loose capscrews. Replace them with new capscrews.
2. Use a torque wrench to verify that capscrews are tightened to 115-135 lb-ft (155-183 N•m). 

Wing-Style Permalube™ Drivelines

1. Check that both capscrews and lock washers are installed on all universal joint positions. RPL Series Permalube™ capscrews and Wing-Style Permalube™ capscrews are not interchangeable.
 - **If the capscrews and lock washers are missing:** Check for damage to the universal joint and yoke. Replace damaged parts and capscrews and lock washers.
 - **If the capscrews are loose:** Remove and discard the loose capscrews. Replace them with new capscrews and lock washers.
2. Use a torque wrench to verify that capscrews are tightened to the correct specification.

Check End Play

1. Check the universal joint for end play. Apply force in an UP-AND-DOWN and SIDE-TO-SIDE motion. The universal joint must not move in either direction. Figure 4.15. There should be less than 0.006-inch (0.152 mm) BACK-AND-FORTH motion of the universal joint. Figure 4.16.
 - **If movement is greater than 0.006-inch (0.152 mm):** Replace the universal joint.

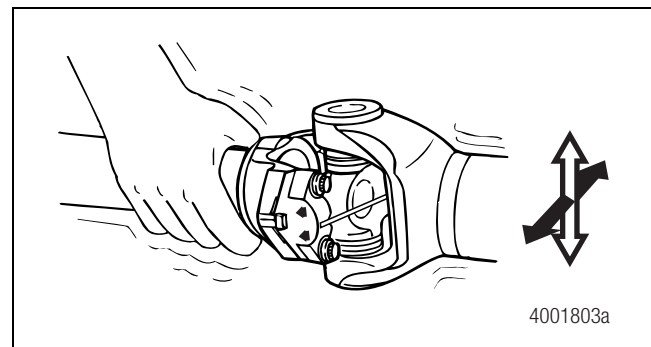

Figure 4.15

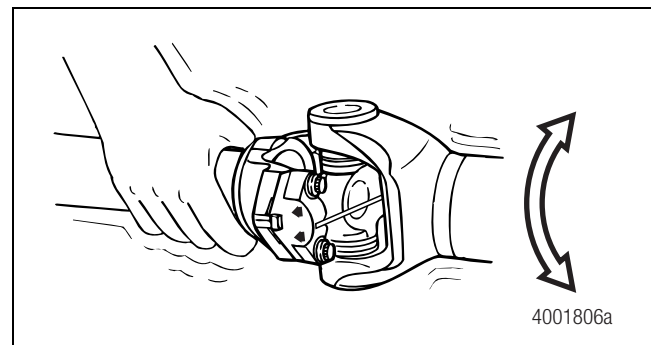

Figure 4.16

CAUTION

A broken weld strap can cause a wing bushing to rotate. When a bushing rotates, it's possible to assemble it into the yoke backward. To ensure correct assembly and prevent damage to components, you must insert both of the wing bushing's machined keyways into the yoke.

2. Replace the universal joint if it's loose or the weld strap is broken or missing.

Lubrication

Xtended Lube MXL™ 17N, 176N and 18N Series Drivelines (Full Round)

The Meritor Xtended Lube MXL™ 17N, 176N and 18N Series drivelines have extended lubrication intervals for both the slip sections and universal joints at 100,000 miles (160 000 km) for linehaul applications.

How to Identify an Xtended Lube MXL™ Series Driveline

- The slip yoke seal includes a protective steel shroud to improve sealing and retain seals securely in place. Figure 4.17.
- The universal joint cover plates are stamped "MXL." Figure 4.17.

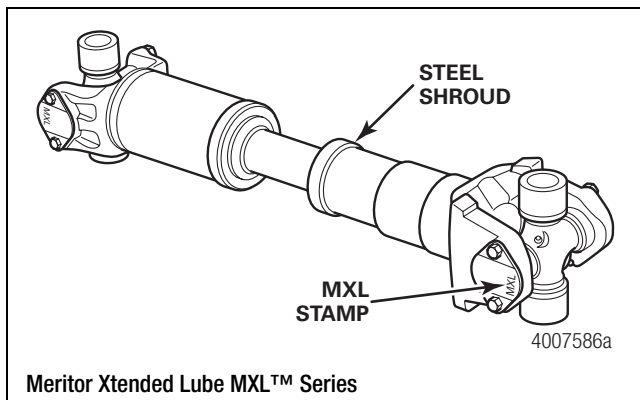

Meritor Xtended Lube MXL™ Series

Figure 4.17

Universal Joint

After installation into the end yokes, lubricate the universal joints at the grease fitting until grease flows from the bearing cup seals on all four trunnions. Use Meritor grease specification O-634-B, NLGI Grade 2 with EP additive. Figure 4.18.

- **If grease does not purge from the seals:** Follow the steps below.

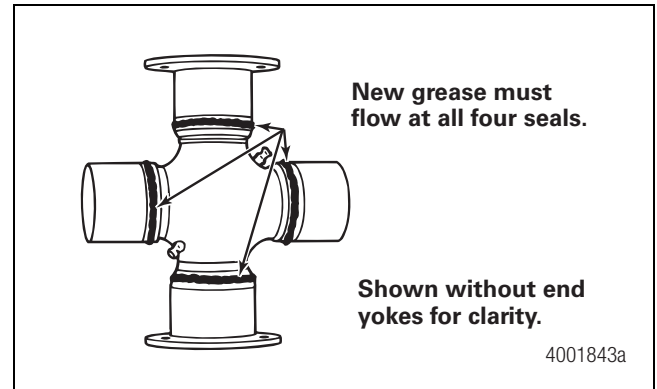

Figure 4.18

1. Move the assembly UP-AND-DOWN or SIDE-TO-SIDE while you apply grease gun pressure. Figure 4.19.

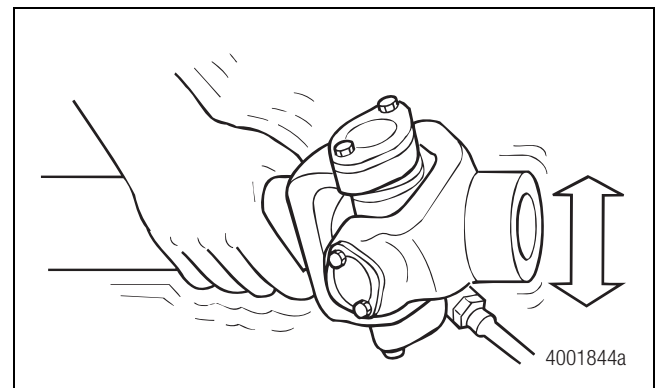

Figure 4.19

2. Loosen the bearing cup capscrews. Add grease until grease purges from the seals.
 - **If grease still does not purge from all four trunnion seals:** Remove the universal joint and correct the problem.
 - **If you cannot determine the problem:** Replace the universal joint.
3. Tighten the capscrews.

Slip Yoke Splines

NOTE: To ensure correct and adequate lubrication of the splines, the slip assembly should be fully collapsed or nearly fully collapsed before applying grease.

Add Meritor specification O-634-B, NLGI Grade 2 with EP additive to the slip yoke grease fitting as shown in Figure 4.20.

4 Drivelines

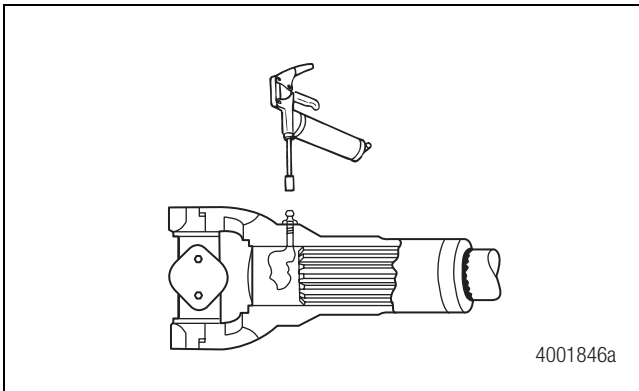

Figure 4.20

The amount of grease will vary with the driveline series. To avoid purging excess grease through the slip yoke Welch plug when the assembly is fully collapsed, follow the recommendations in Table X.

Table X

| Driveline Series | Grease Volume | Number of Pumps |
|------------------|-------------------|-----------------|
| 17N | 0.7 oz (20 grams) | 4-6 |
| 176N | 0.7 oz (20 grams) | 4-6 |
| 18N | 1.1 oz (30 grams) | 6-8 |

RPL Series Permalube™ Driveline Universal Joint, Slip Yoke and Splines

The universal joint, slip yoke and splines are permanently lubricated and sealed and do not require regular lubrication. Figure 4.21.

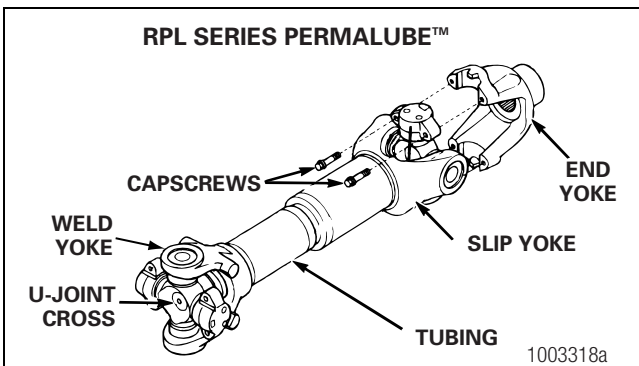

Figure 4.21

Standard/Conventional Driveline Universal Joint

1. Check the driveline for looseness. If loose, service the driveline as necessary. Figure 4.22.

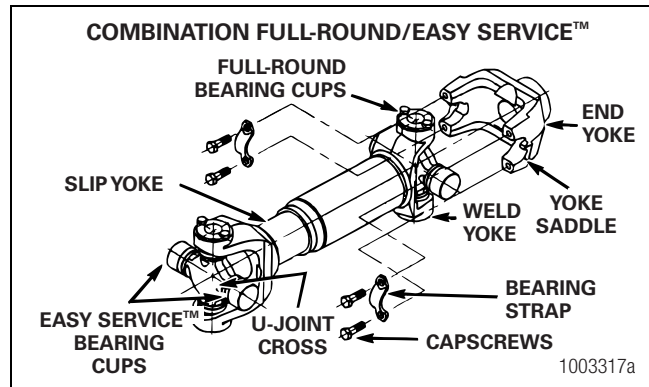

Figure 4.22

2. Clean all grease fittings prior to lubrication.
3. Apply the specified grease at the grease fitting on the universal joint. Apply grease until new grease purges from all four seals.
 - If new grease does not purge at all the seals: Loosen the problem bearing cap bolts and regrease until all four cups purge.
 - If new grease still does not purge: Replace the universal joint.

Standard/Conventional Driveline Slip Yoke and Splines

1. Check the driveline for looseness. If loose, service the driveline as necessary. Figure 4.22.
2. Cover the vent hole in the Welch plug with a finger.
3. Apply the specified grease at the grease fitting on the slip yoke until the grease purges from the deflector. Six to eight pumps or approximately one ounce (28 grams) is sufficient to lube the splines.

Wing-Style Permalube™ Driveline Universal Joint

The universal joint is permanently lubricated and does not require regular maintenance. Figure 4.23.

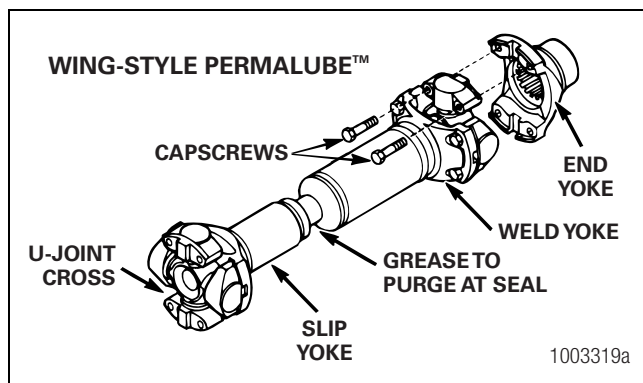

Figure 4.23

Wing-Style Greaseable Driveline Universal Joint

1. Check the driveline for looseness. If loose, service the driveline as necessary.
2. Clean all grease fittings prior to lubrication.
3. Apply the specified grease at the grease fitting on the universal joint. Apply grease until new grease purges from all four seals.
 - **If new grease does not purge at all the seals:** Loosen the problem bearing cap bolts and regrease until all four cups purge.
 - **If new grease still does not purge:** Replace the universal joint.

Wing-Style Permalube™ and Greaseable Driveline Slip Yoke and Splines

1. Check the driveline for looseness. If loose, service the driveline as necessary.
2. Clean all grease fittings prior to lubrication.
3. Cover the vent hole in the welch plug.
4. Apply the specified grease at the grease fitting on the slip yoke until grease purges from the deflector. Six to eight pumps or approximately one ounce (28 grams) is sufficient to lube the splines.

4 Drivelines

Intervals

Inspection and Maintenance

Table Y: RPL Series Permalube™ and Wing-Style Permalube™ Driveline Inspection Intervals and Procedures

| Mileage Intervals | Procedures |
|--|---|
| At initial inspection, or no more than 2,000 miles (3200 km) | Verify that all bolts are tightened to 115-135 lb-ft (155-183 N•m).  |
| Every 25,000 miles (40 000 km) | If you observe any of the following conditions, remove and replace components as needed. <ol style="list-style-type: none">Inspect all universal joints for grease leakage.<ul style="list-style-type: none">If a universal joint shows normal grease leakage: Do not replace the universal joint.If a universal joint shows excessive grease leakage: Replace the universal joint.Check for excessive looseness across the ends of the universal joint bearing cup assemblies and trunnions.<ul style="list-style-type: none">Grip the driveline near the INBOARD yoke with both hands.Try to move the yoke VERTICALLY and HORIZONTALLY. Movement in the universal joint relative to the INBOARD or OUTBOARD yokes must not exceed 0.006-inch (0.152 mm). Figure 4.24.Inspect the slip yoke spline seal for grease leakage or seal damage.Inspect for missing balance weights, damaged tubing or a missing welch plug at the slip yoke. |
| Every 150,000 miles (240 000 km) | In addition to the 25,000-mile (40 000 km) requirements: <ul style="list-style-type: none">Use a dial indicator to inspect the slip splines for wear (backlash). Radial looseness between the slip yoke and the tube shaft must not exceed 0.017-inch (0.432 mm). Figure 4.25. |

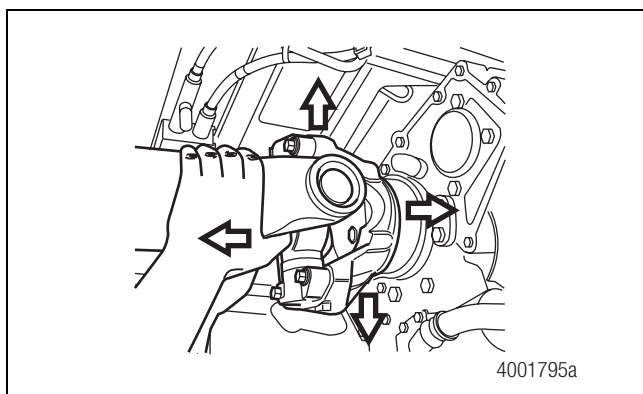

Figure 4.24

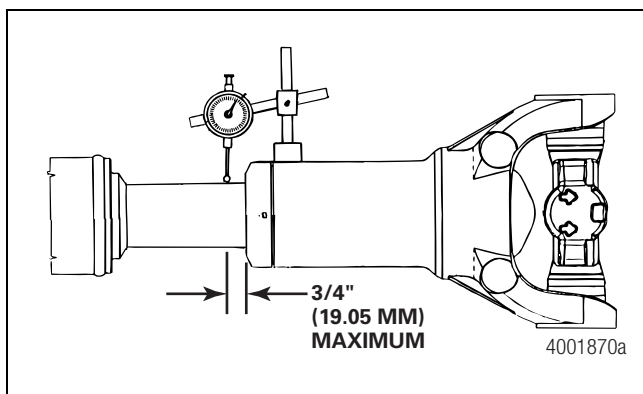

Figure 4.25

Table Z: Driveline Styles

| Industry Name/Description | Series | Type | Lubrication Requirements |
|------------------------------------|--------|---------------------------|------------------------------|
| Standard or Conventional Driveline | 16N | Xtended | Splines and Universal Joints |
| | 17N | Lube MXL™ (Full-Round) | |
| | 176N | | |
| | 18N | | |
| | 16T | Easy Service™ (1/2 Round) | |
| | 17T | | |
| | 176T | | |
| | 18T | | |
| Wing-Style Greaseable | 155R | 1/2 Round | |
| Wing-Style Permalube™ | 92N | Wing-Style | |
| Wing-Style Permalube™ | 92N | Wing-Style | Splines Only |
| RPL Series (Meritor Permalube™) | RPL 25 | Combination | None |
| | RPL 20 | Wing and Full-Round | |

4 Drivelines

Lubrication Intervals and Specifications

Table AA: Greasing Intervals and Specifications for Full-Round, Easy Service™, Wing-Style and 115R Greasable Drivelines

| Component | Application | Greasing Interval | Grease | Meritor Specification | NLGI Grade | Grease Description | Outside Temperature |
|--|--|--|------------------------|-----------------------|------------|---|---|
| Universal Joint, Slip Yoke and Splines | Line Haul — Applications where tractor is operated entirely on concrete or smooth paved road surfaces | 50,000 miles (80 000 km) | Universal Joint Grease | O-634-B | 2 | Lithium 12-Hydroxy Stearate with Molybdenum Disulfide | Refer to the grease manufacturer's specifications for the temperature service limits. |
| | On Highway — Applications where tractor is operated at least 90% on paved road surfaces and up to 10% on gravel, dirt or unpaved roads | 16,000 miles (25 000 km) | | | | | |
| | City — Applications where truck is operated at least 90% in city environment | 6,500 miles (10 000 km) | | | | | |
| | Construction — Straight trucks used in the construction industry to move materials to and from job sites. They operate 90% on-road and 10% off-road with a high number of stops and starts | The greasing interval depends on the individual operating conditions, speed and loads. To determine the interval, inspect for the presence of grease at all positions until an interval can be determined. Grease the assembly as necessary. | | | | | |

Lubrication Intervals for Xtended Lube MXL™ Series Drivelines

Table AB: Lubrication Intervals

| Application | MXL* 17N-18N | RN 155N-18N |
|--------------|--|-----------------------------|
| City | 25,000 miles (40 000 km) or 6 months | 6,500 miles (10 400 km) |
| On Highway | 100,000 miles (160 000 km) | 16,000 miles (25 000 km) |
| Linehaul | 100,000 miles (160 000 km) | 50,000 miles (80 000 km) |
| Construction | The greasing interval depends on the individual conditions, speed and loads. To determine the interval, inspect for the presence of grease at all positions until an interval can be determined. Grease the assembly as necessary. | |

*Xtended Lube MXL™ Series drivelines are identifiable from RN drivelines in the following two ways. (1) The slip yoke seal includes a protective steel shroud. (2) The universal joint cover plates are stamped with MXL™.

Meritor RPL25/20 Series drivelines are permanently lubricated. No greasing is required.

Table AC: Approved Lubricants

| Lubricant | Recommendation |
|------------------------|---|
| Universal Joint Grease | Must meet Meritor Specification O-634-B (NLGI Grade 2, Lithium 12-Hydroxy Stearate with Molybdenum Disulfide) Amalie All Purpose Grease with Moly-L1-2M Exxon 5160 Shell Super Duty Special FF Marathon Maralube Molycode 529 Phillips Petroleum Philube MW-EP2 Grease Shell Moly Poly Grease Kendall L424 Grease Amoco Super Chassis Grease Ford Specification M1C-75B or part number PN-C1AZ 19590 |

4 Drivelines

Troubleshooting

WARNING

To prevent serious eye injury, always wear safe eye protection when you perform vehicle maintenance or service.

Table AD: Vibration

| Condition | Cause | Correction |
|---|--|--|
| Driveline vibration | Driveline phasing incorrect | Correct the phasing by aligning the yokes on both ends of the driveline. |
| | Missing balance weights or foreign material on driveline tubing | Have the driveline balanced. |
| | Transmission or axle end yokes loose | Inspect for radial looseness. Tighten the nut or replace the end yoke. |
| | Excessive end play in universal joints | Replace the universal joints. |
| | Excessive hinging in slip section | Replace worn components. |
| | Welch plug loose or missing in slip yoke | Replace the welch plug or slip yoke. |
| | Worn center bearing | Replace the center bearing. |
| | Chassis ride height too low or too high | Readjust the ride height. |
| | Torsional accelerations in driveline | Measure the transmission, driveline and axle planes. Record the readings and run the Driveline Analysis Program. If the angles are found to be out of specifications, adjust or replace components as directed. |
| | Low gear shudder at full drive or full coast under light load conditions | Incorrect phasing |
| Driveline weight incompatible with engine-transmission mounting | | Install a two-piece driveline with a shaft support bearing. |
| Driveline too long for speed | | Install a two-piece driveline with a shaft support bearing. |
| Loose outside diameter fit on slip yoke spline | | Change the slip yoke and spline plug. |
| Universal joint loose | | Inspect the universal joint for looseness; tighten to specification. Replace if necessary. |
| Driveline out of balance or bent | | Rebalance or replace. |
| Worn universal joint | | Replace the universal joint. |
| Torsional or inertial excitation | | Reduce the universal joint continuous running angle by adding shims to driveline components. |

Table AE: Premature Wear

| Condition | Cause | Correction |
|--|--|---|
| Low mileage universal joint wear | End yoke cross hole misalignment | Use an alignment bar to check for end yoke cross hole misalignment. Replace the end yoke if misaligned. |
| | Excess angularity | Check the universal joint operating angles. Reduce the angles if necessary. |
| | Incorrect lubrication | Lubricate according to specifications (non-RPL designs). |
| Repeat universal joint wear | Excessive continuous running load | Replace with a higher capacity universal joint and driveline. |
| | Continuous operation at high angle/high speed | Replace with a higher capacity universal joint and driveline. Check the universal joint operating angles. Reduce the angles if necessary. |
| | Worn or damaged seals | Replace the universal joint kit. |
| End galling of cross trunnion and bearing assembly | Excessive angularity | Check the universal joint operating angles. Reduce the angles if necessary. |
| | Excessive torque load for universal joint and driveline size | Replace with a higher capacity universal joint and driveline. |
| Needle rollers brinelled into bearing cup and cross trunnion | Excessive continuous running load | Replace with a higher capacity universal joint and driveline. |
| | Continuous operation at high angle/high speed | Replace with a higher capacity universal joint and driveline. Check the universal joint operating angles. Reduce the angles if necessary. |
| | Insufficient operating angles | Increase the operating angles to a minimum of 2°. |
| Broken cross and bearing assemblies | Excessive torque load for universal joint and driveline size | Replace with a higher capacity universal joint and driveline. |

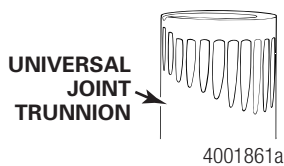
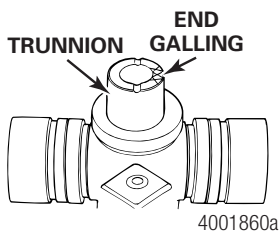

4 Drivelines

Table AF: Slip Yoke Spline Wear

| Condition | Cause | Correction |
|---|---|---|
| Seizure | Incorrect lubrication | Lubricate the slip yoke spline according to specifications. Check the seal. |
| | Worn or damaged part | Replace the spline components. |
| | Contamination | Lubricate the slip yoke spline according to specifications. Check the seal. |
| Galling | Worn or damaged parts | Replace the spline components. |
| | Contamination | Lubricate the slip yoke spline according to specifications. Check the seal. |
| Outside diameter wear at extremities | Incorrect lubrication | Lubricate the slip yoke spline according to specifications. Check the seal. |
| | Excessive loose outside diameter fit | Replace the spline components. |
| Spline shaft or tube broken in torsion | Tube size inadequate | Use a larger diameter tube. |
| | Excessive torque load for universal joints and driveline size | Replace with a higher capacity universal joint and driveline. |

Table AG: Shaft and Tube

| Condition | Cause | Correction |
|--|--|---|
| Shaft support bearing wear | Driveline too long for operating speeds | Install a two-piece driveline with a shaft support bearing. |
| Shaft support rubber insulator wear | Incorrect lubrication of bearings | Replace the center bearing. |
| | Bending fatigue due to secondary couple loads | Reduce the universal joint continuous running angle. |
| | Excessive torque load for universal joint and driveline size | Replace with a higher capacity universal joint and driveline. |
| | Shaft support bearing misaligned; interferes with deflector | Realign the mounting bracket to frame crossmember to eliminate interference with the deflector. |
| Tube circle weld fracture | Balance weight located in apex of weld yoke lug area | Replace the tubing and rebalance. |
| | Balance weight too close to circle weld | Replace the tubing and rebalance. |
| | Incorrect circle weld | Replace the tubing and rebalance. |

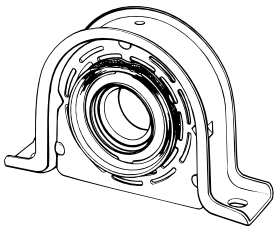

4001863a

Table AH: Yoke Fracture

| Condition | Cause | Correction |
|-------------------------------|--|---|
| Yoke broken or cracked | Mating yoke lug interference at full jounce and rebound | Replace the yoke. Check the design for application. Use high angle yokes. |
| | Excessive torque load for universal joint and driveline size | Replace with a higher capacity universal joint and driveline. |
| | Bending fatigue due to secondary couple loads | Reduce the universal joint continuous running angles. |

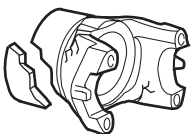

4001864a

Hazard Alert Messages

Read and observe all Warning and Caution hazard alert messages in this publication. They provide information that can help prevent serious personal injury, damage to components, or both.

⚠ WARNING

To prevent serious eye injury, always wear safe eye protection when you perform vehicle maintenance or service.

Park the vehicle on a level surface. Block the wheels to prevent the vehicle from moving. Support the vehicle with safety stands. Do not work under a vehicle supported only by jacks. Jacks can slip and fall over. Serious personal injury and damage to components can result.

Technical Publications

How to Obtain Additional Maintenance and Service Information

Refer to the publications in Table AI. To obtain these publications, refer to the Service Notes page on the front inside cover of this manual.

Table AI: Publications

| Model | Maintenance Manual |
|---|---------------------------------|
| MX Series Medium-Duty Front Drive Steer Axles | Maintenance Manual MM-0170 |
| Heavy-Duty Front Drive Steer Axles | Maintenance Manual 12 |
| Single Reduction Differential Carriers | Maintenance Manual 5 |
| Front Drive Axles | Failure Analysis Manual TP-0445 |

Description

Front Drive Steer Axles

Meritor produces a complete line of medium-duty and heavy-duty front drive steer axles with single axle capacities of 10,000 lbs (3732 kg) to 23,000 lbs (10 432 kg). Figure 5.1. Axle models are available with:

- Single-reduction carriers
- Q Plus™ S-cam brakes
- Standard or wide track
- Driver-controlled main differential lock for increased traction

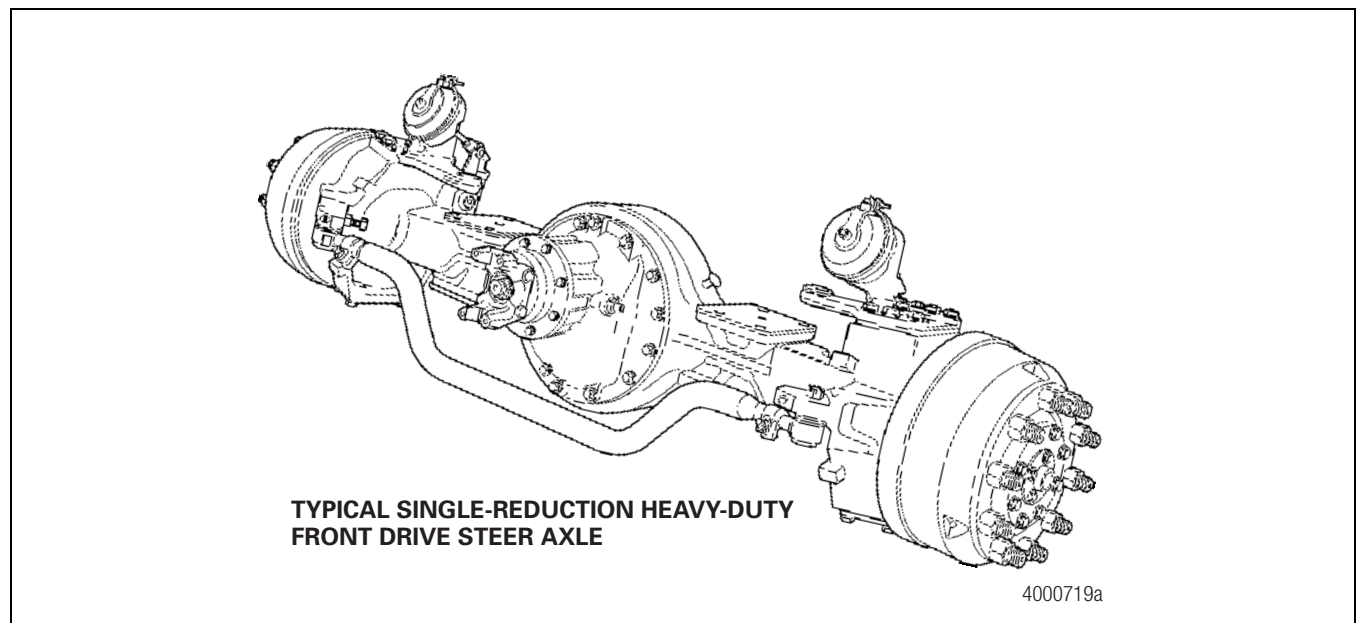

Figure 5.1

5 Front Drive Steer Axles

Current Models

| | |
|-----------|------------|
| MX-10-120 | MX-19-145 |
| MX-12-120 | MX-21-160 |
| MX-14-120 | MX-23-160R |
| MX-16-120 | |

Prior Models

| | |
|-----------|-----------|
| RF-16-145 | RF-21-355 |
| RF-21-155 | RF-22-166 |
| RF-21-156 | RF-23-180 |
| RF-21-160 | RF-23-185 |
| FDS-1600 | FDS-2102 |
| FDS-1805 | FDS-2107 |
| FDS-1807 | FDS-2110 |
| FDS-1808 | FDS-2111 |
| FDS-2100 | FDS-2117 |
| FDS-2101 | |

Model Nomenclature

Front Drive Steer Axles

Front drive steer axle models are identified by a letter and number system. The letters and numbers give important information about the specific axle model.

The first seven positions of the designations identify a basic axle model. The second group of letters and numbers identify particular specifications.

As an example, a 16,000 lb (7258 kg) front drive steer axle with a single-reduction 120 model carrier is identified by the following:

Identification

The axle build information and assembly date for Meritor front drive steer axles are on the axle identification tag. Figure 5.2.

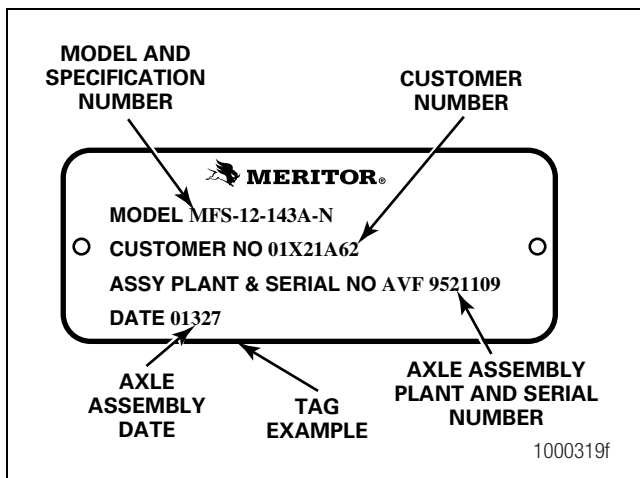
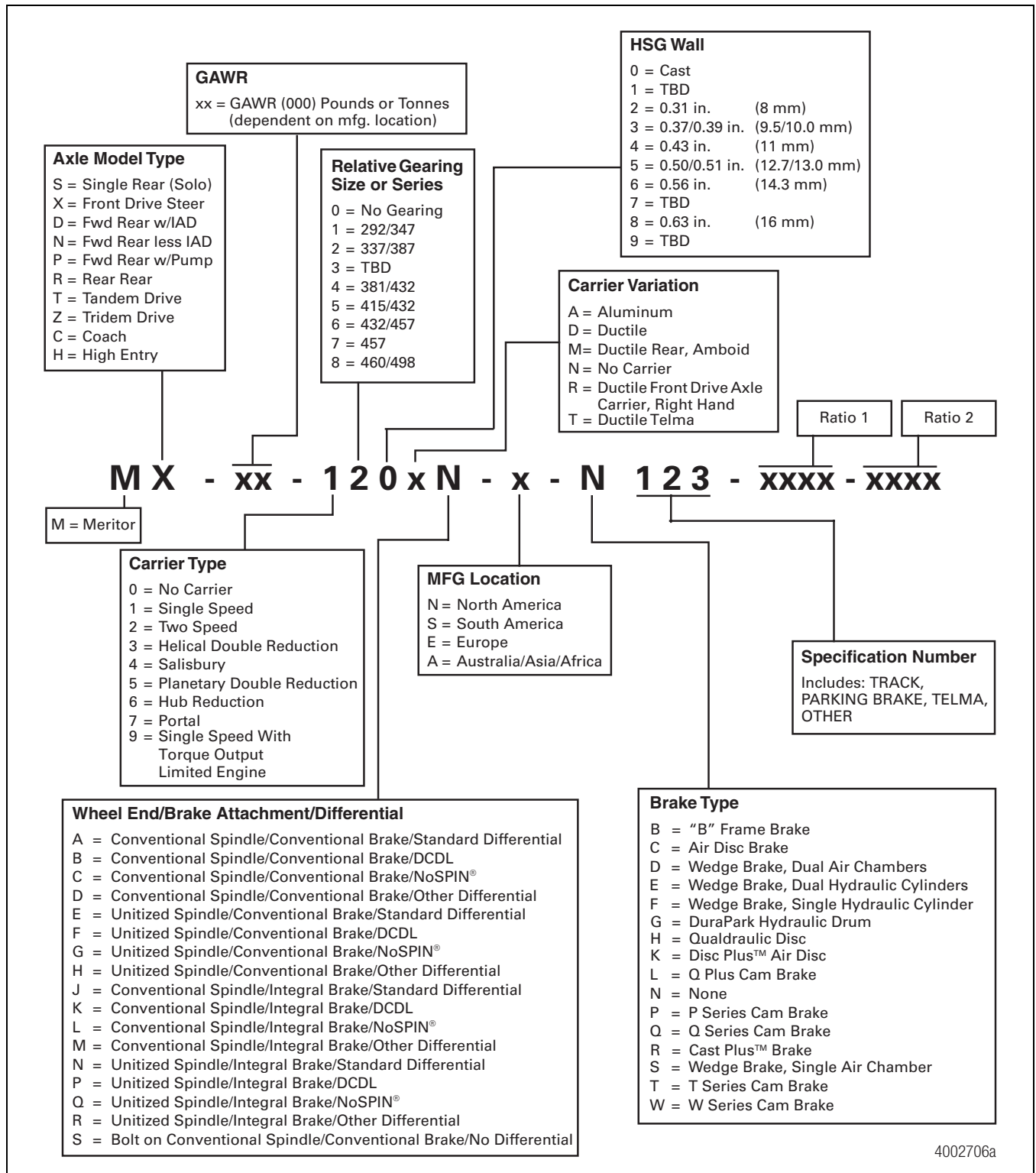

Figure 5.2

The identification tag is fastened to the axle housing.



5

5 Front Drive Steer Axles

Front Drive Steer Axles, Prior Models

Front drive steer axle models manufactured from 1989 to 2002 are identified by a letter and number system. The letters and numbers give important information about the specific axle model.

The first seven positions of the designations identify a basic axle model. The second group of letters and numbers identify particular specifications.

As an example, a 16,000 lb (7258 kg) front drive steer axle with a single-reduction 145 model carrier is identified by the following:

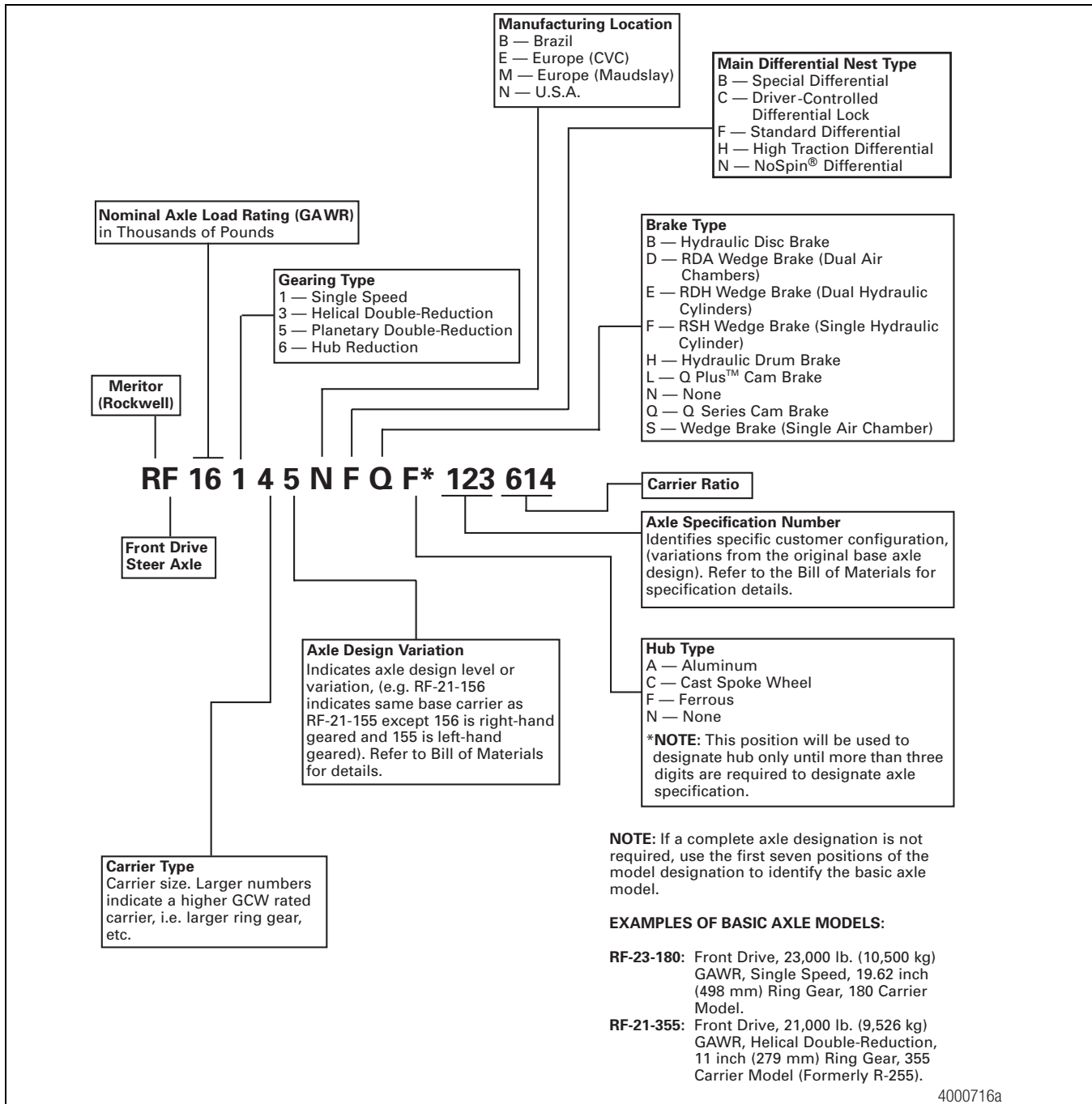

Meritor heavy-duty front drive steer axle models manufactured before 1989 were identified as shown in Figure 5.3. For example, an 18,000 lb (8165 kg) front drive steer axle with a double-reduction 255 carrier model was identified as FDS-1805-SAX-60 10.59.

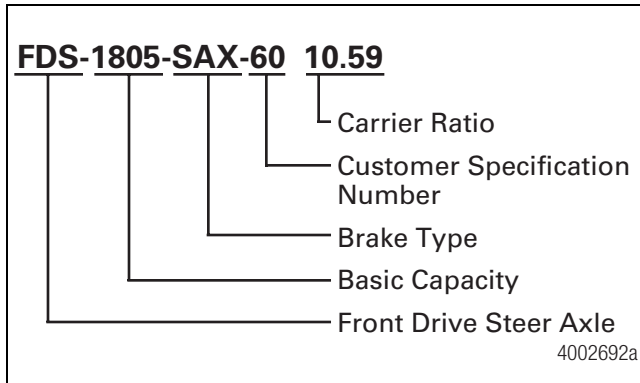

Figure 5.3

Meritor makes a complete line of FDS series front drive axles with single axle capacities of 7,500 lb (3400 kg) to 23,000 lbs (10 500 kg).

FDS series front drive axle model designations show the capacity, carrier model and design modifications of each model. The letters and numbers of the model designation correspond with information listed in Table AJ.

Table AJ: Front Drive Steer Axle Model Specifications

| Axle Model | Capacity, lb (kg)* | Carrier Model | Design Modification |
|------------|-----------------------------|---------------|---------------------------------|
| FDS-75 | 7,500 (3400) | F-106 | Standard |
| FDS-78 | 7,500 (3400) | F-106 | Heavy-duty wheel ends |
| FDS-85 | 9,000 (4082) | H-140 | Special carrier |
| FDS-90 | 9,000 (4082) | F-106 | Standard |
| FDS-93 | 9,000 (4082) | F-106 | Special track and offset bowl |
| FDS-1600 | 16,000 (7257) | H-140 | Right-hand or left-hand gearing |
| FDS-1805 | 18,000-21,000 (8165-9525) | R-255 | Double-reduction |
| FDS-1807 | 18,000-21,000 (8165-9525) | R-155 | Single-reduction |
| FDS-1808 | 18,000-21,000 (8165-9525) | R-155 | Right-hand gearing |
| FDS-2100 | 21,000 (9525) | R-155 | Right-hand gearing |
| FDS-2101 | 21,000 (9525) | R-155 | Left-hand gearing |
| FDS-2102 | 21,000-23,000 (9525-10 433) | R-255 | Double-reduction |
| FDS-2107 | 23,000 (10 433) | R-170 | Single-reduction |
| FDS-2110 | 21,000 (9525) | R-155 | Wide track, right-hand gearing |
| FDS-2111 | 21,000 (9525) | R-155 | Wide track, left-hand gearing |
| FDS-2112 | 21,000 (9525) | R-255 | Wide track, double-reduction |
| FDS-2117 | 23,000 (10 433) | R-170 | Wide track, single-reduction |

*Capacities vary with application and service. All applications must be approved by the Meritor Engineering Department.

5 Front Drive Steer Axles

Inspection

Steering-Related Components

Fasteners

Verify that all fasteners are tightened to the specified torque. Use a torque wrench to check the torque in a tightening direction. As soon as the fastener starts to move, record the torque. Correct if necessary. Replace any worn or damaged fasteners.

Wear and Damage

Inspect the parts of the axle for wear and damage. Look for bent or cracked parts. Replace all worn or damaged parts.

Pivot Points

Verify that looseness does not exist at the pivot points. Verify that the pivot points are lubricated.

Operation

Verify that all the parts move freely through the complete turning radius.

Tire Wear

Inspect the tires for wear patterns that indicate suspension damage or misalignment.

Steering Arm Bolts

Check torque every 200,000 miles (320 000 km).

Steering Knuckle Vertical End Play

1. Park the vehicle on a level surface and block the wheels to prevent the vehicle from moving.
2. Use a jack to raise the vehicle until the front wheels are off the ground. Support the front axle with safety stands.
3. Install a dial indicator for each side of the axle beam.
 - A. Turn the wheels straight ahead.
 - B. Install the dial base on the axle beam.
 - C. Place the dial indicator tip onto the upper knuckle cap.
 - D. Place a jack and a wood block, with a hole that allows clearance for the lower grease fitting, under the lower king pin cap area. Figure 5.4.

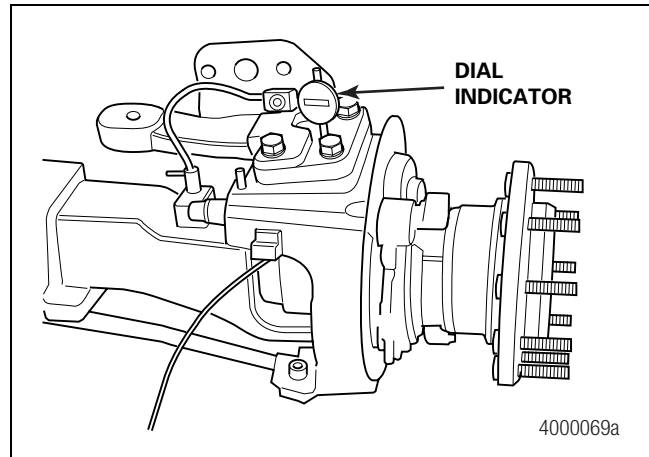

Figure 5.4

- E. Set the dial indicator on ZERO.
 - F. Raise the jack until you start to lift the axle beam off the safety stands. Measure and record the dial indicator reading.
 - G. Lower the jack.
4. For medium-duty axles, the reading must be 0.001-0.065-inch (0.025-1.650 mm) for new axles and 0.001-0.075-inch (0.025-1.905 mm) for axles in service.
For heavy-duty axles, the reading must be 0.005-0.015-inch (0.127-0.381 mm). Figure 5.4.

- **If the reading is not within specification:** The axle components are damaged and must be replaced.

Upper and Lower Knuckle Bushings

1. Park the vehicle on a level surface. Place blocks under the wheels not being serviced to prevent the vehicle from moving.
2. Raise the vehicle so that the wheels to be serviced are off the ground. Support the vehicle with safety stands.
3. Check the upper king pin bushing for wear. Install the base of a dial indicator onto the axle beam. Place the indicator tip against the side of the knuckle top, curbside or against the king pin cap, driver side. Figure 5.5.
4. Set the dial indicator on ZERO.

5. Move the top of the tire side-to-side TOWARD and AWAY from the vehicle.
 - **If the dial indicator moves a total of 0.010-inch (0.254 mm):** The upper bushing is worn or damaged. Replace both bushings in the knuckle. Refer to the appropriate maintenance manual for complete service information. Figure 5.5.

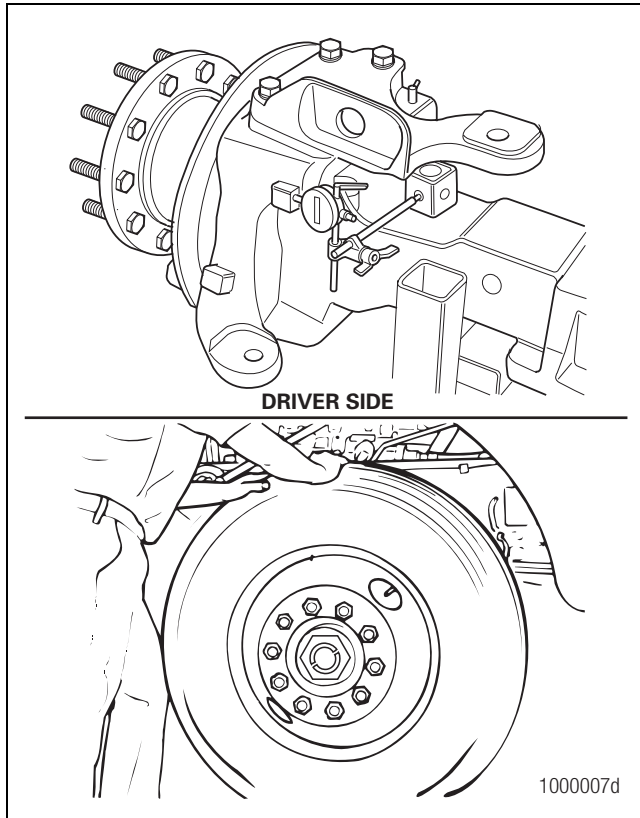

Figure 5.5

6. Check the lower king pin bushing. Install a dial indicator so that the base is on the I-beam and the tip is against the side of the bottom of the knuckle. Figure 5.6.
7. Set the dial indicator on ZERO.
8. Move the bottom of the tire side-to-side TOWARD and AWAY from the vehicle.
 - **If the dial indicator moves a total of 0.010-inch (0.254 mm):** The lower bushing is worn or damaged. Replace both bushings in the knuckle. Refer to the appropriate maintenance manual for complete service information. Figure 5.6.

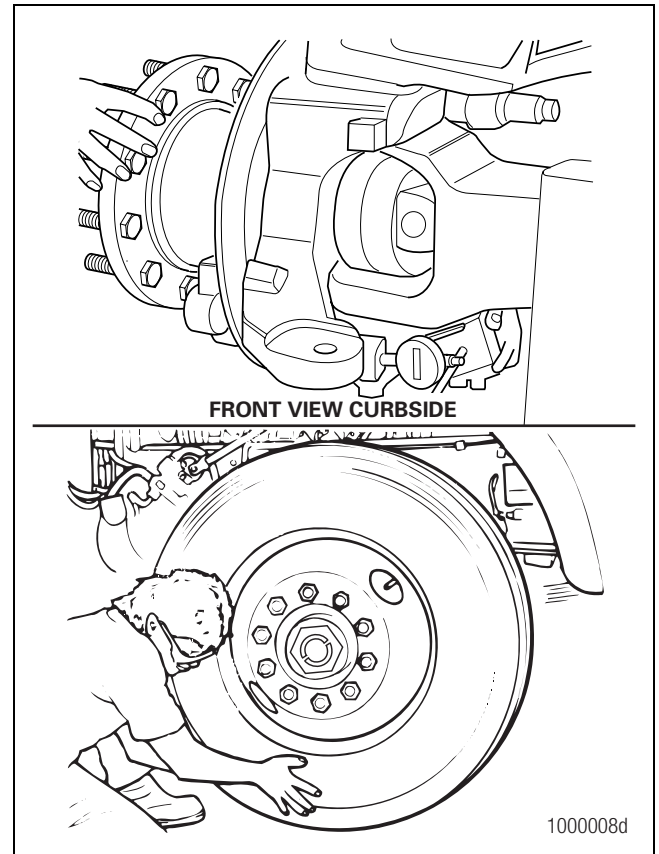

Figure 5.6

Tie Rod Ends

1. Park the vehicle on a level surface with the front wheels in the straight-ahead position.
2. Place blocks under the rear wheels to prevent the vehicle from moving.
3. Remove dirt and grease from the tie rod end seals.
4. Place the dial indicator base on the bottom of the tie rod arm.
5. Place the indicator tip near the tie rod end greasing fitting. Figure 5.7. Set the dial indicator on ZERO.

5 Front Drive Steer Axles

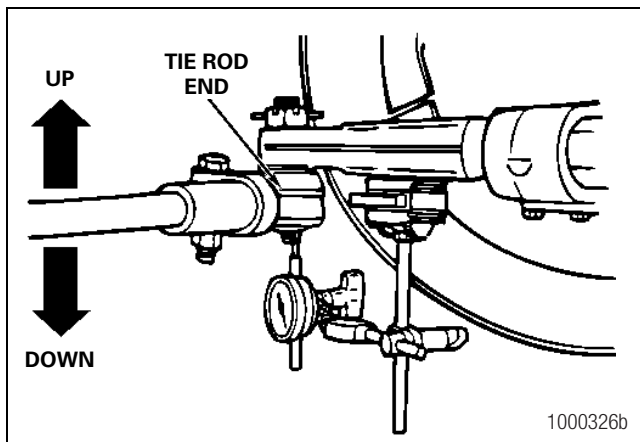

Figure 5.7

⚠ CAUTION

Check the tie rod end play by hand. Do not use a pry bar which can affect the accuracy of the dial indicator reading. Damage to components can result.

6. Move the tie rod end cross tube assembly UP and DOWN by hand. Record the dial indicator reading.
 - If the dial indicates a reading of more than 0.060-inch (1.52 mm): Replace the tie rod end.
7. Place the dial indicator on the tie rod end assembly at the opposite side of the vehicle.

Servicing the Tie Rod Ends

When performing service and maintenance procedures, use a service pit, if available. Otherwise, use one of the following procedures.

Safety Stands

NOTE: Do not grease the tie rod assembly before you perform the inspection.

1. Park the vehicle on a level surface. Place blocks under the wheels not being serviced to prevent the vehicle from moving.
2. Raise the vehicle so that the area to be serviced is off the ground. Support the vehicle with safety stands.
3. Inspect and lubricate the tie rod ends.

Ramps

1. Drive the vehicle onto ramps. Follow the ramp manufacturer's instructions.
2. Inspect and lubricate the tie rod ends.

Why It's Important to Inspect the Tie Rod Ends for Wear and Allowable Movement at the Regularly-Scheduled Intervals

You may not be able to detect loose or worn tie rod ends during operation. Under normal operating conditions, wear occurs over time. The preload bearings inside each tie rod end provide less resistance, which can affect steering control, front tire wear and other axle components. Figure 5.8.

Regularly-scheduled inspection and maintenance helps to minimize the effects of tie rod end wear on the vehicle. Figure 5.8.

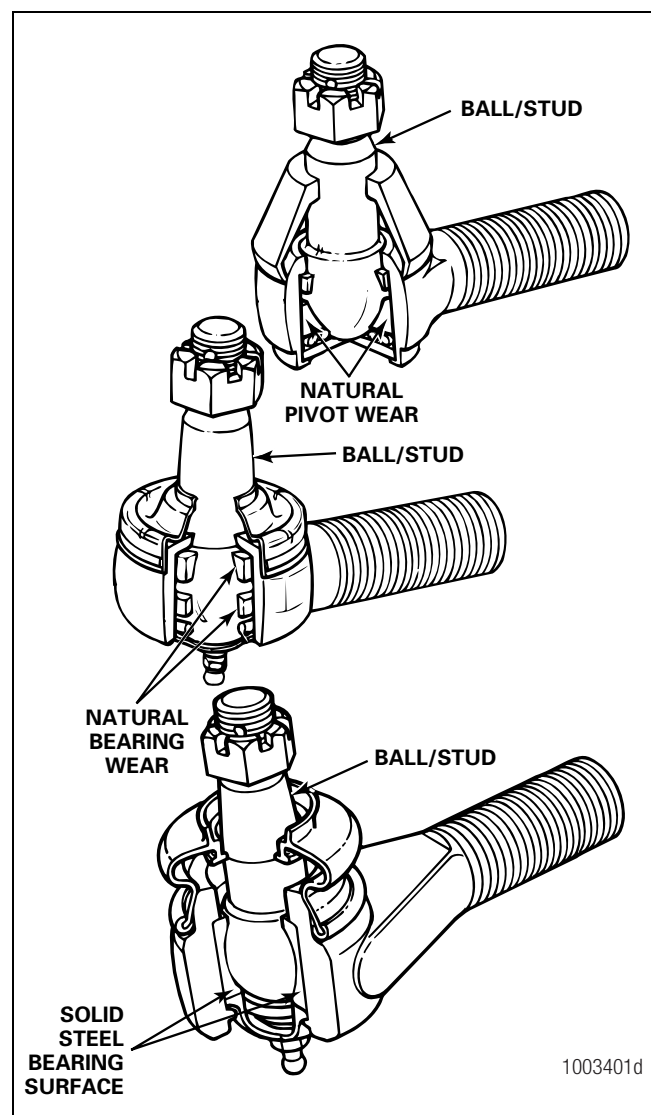

Figure 5.8

Tie Rod Assembly Movement

NOTE: Do not grease the tie rod assembly before you perform the inspection.

1. Park the vehicle on a level surface. Place blocks under the rear wheels to prevent the vehicle from moving.
2. Raise the front end of the vehicle off the ground. Support the vehicle with safety stands.
3. With the engine off, turn the wheels from full left to full right, and then return to the straight-ahead position. This step will require more force for vehicles with the power steering off.

NOTE: The boot may be missing completely or may not completely cover the ball joint.

4. Check that the boot is in place and completely installed over the tie rod end.
5. Check for cracking or tears in the boot. Also check the boot seals for damage. Replace the entire tie rod if the boot is damaged or missing. Figure 5.9.

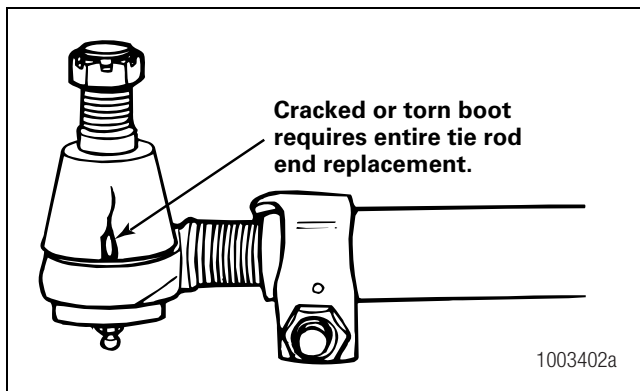

Figure 5.9

⚠ WARNING

Verify that a cotter pin is installed through the tie rod end, and the tie rod end nut is tightened to the correct torque specification. Replace a missing cotter pin and tighten a loose tie rod end nut. A missing cotter pin or loose tie rod end nut can cause loss of steering control. Serious personal injury and damage to components can result.

6. Check that the tie rod end nut is installed and secured with a cotter pin.
 - **If the cotter pin is missing:** Check the nut torque specification. Install a new cotter pin. Always tighten the tie rod end nut to 300 lb-ft (407 N•m) when installing the cotter pin. Figure 5.10. **ⓘ**

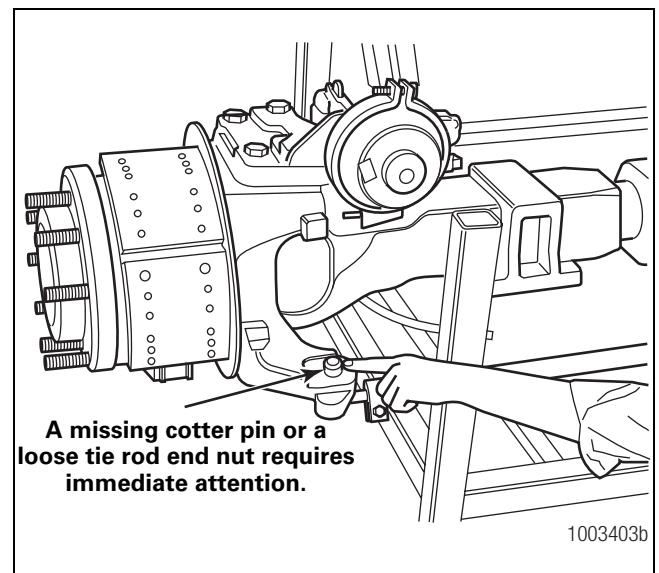

Figure 5.10

7. Check that the tie rod end is threaded correctly into the cross tube and installed deeper than the end of the cross tube slot. The tie rod end must be visible the entire length of the cross tube slot. Figure 5.11.

5 Front Drive Steer Axles

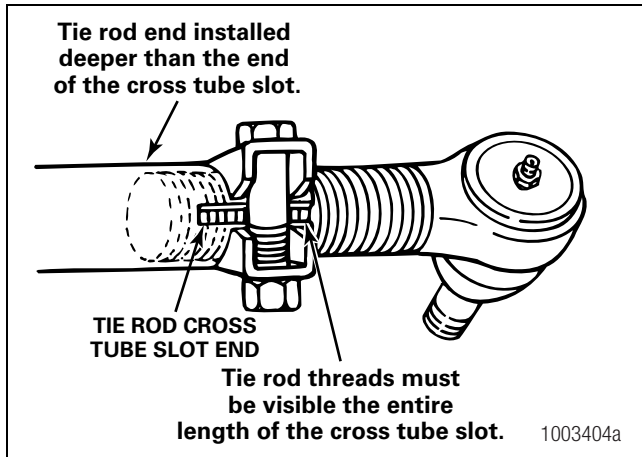

Figure 5.11

8. Check that the grease fittings are installed. Replace a damaged grease fitting.
 - **If the tie rod ends are non-greaseable:** Do not install a grease fitting if the tie rod end is the non-greaseable type. Figure 5.12.

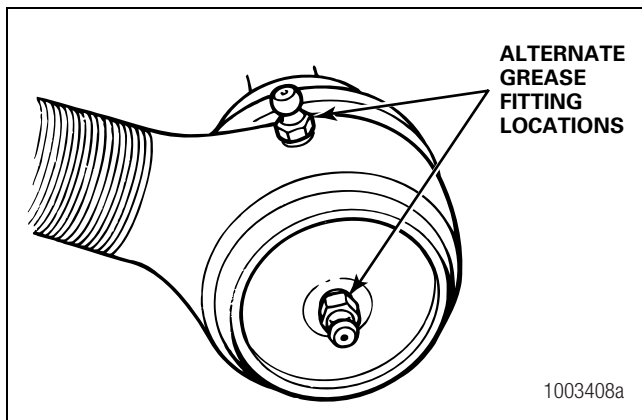

Figure 5.12

9. By hand or using a pipe wrench with jaw protectors to avoid gouging the cross tube, rotate the cross tube toward the FRONT of the vehicle and then toward the REAR.
 - After rotating, center the cross tube.
 - **If the cross tube will not rotate in either direction:** Replace both tie rod ends.
10. Position yourself directly underneath the ball stud socket. Grasp the end of the tie rod assembly with both hands as close as possible to the socket. Your hands should be within 6-inches (152.4 mm) of the socket.

⚠ CAUTION

Only use your hands to check for movement or looseness of the tie rod assembly. Do not use a crow bar, pickle fork or two-by-four. Do not apply pressure or force to the tie rod assembly ends or joints. Do not rock the tires with the vehicle on the round or with the wheels raised. Damage to components can result.

11. Use a push-pull movement to apply approximately 100 pounds (45 kg) of hand pressure several times to the tie rod assembly. Check for movement or looseness at both tie rod ends. Figure 5.13.

- **If there is movement or looseness in the tie rod assembly:** Replace both tie rod ends.

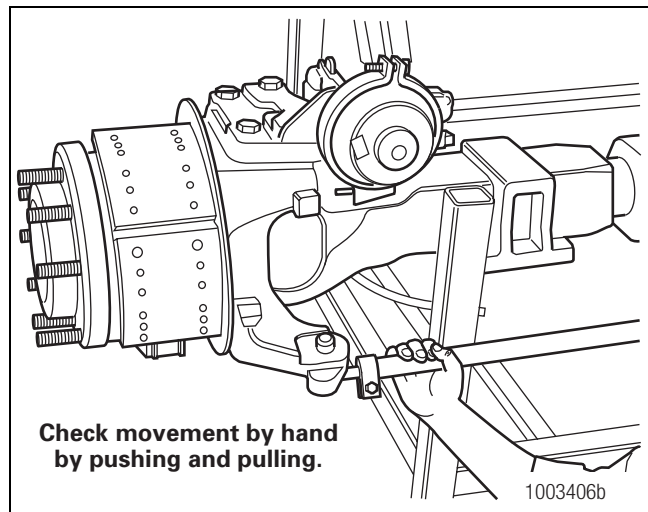

Figure 5.13

⚠ CAUTION

Replace bent or damaged cross tubes with original equipment parts of the same length, diameter and threads. Do not attempt to straighten a bent cross tube. Damage to components can result.

12. Inspect the cross tube and clamps for damage. Figure 5.14.
 - **If the cross tube is bent or cracked:** Replace it. Use original equipment parts of the same length, diameter and threads.
 - **If the clamps are damaged:** Replace them.
 - **If either clamp has become welded to the cross tube:** Replace the entire cross tube assembly. Use original equipment parts of the same length, diameter and threads.

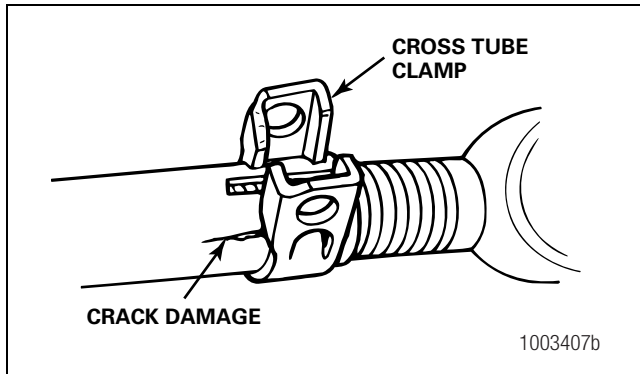

Figure 5.14

Steering Arm Bolts

⚠ WARNING

Take care when you use Loctite® adhesive to avoid serious personal injury. Read the manufacturer's instructions before using this product. Follow the instructions carefully to prevent irritation to the eyes and skin. If Loctite® adhesive material gets into your eyes, follow the manufacturer's emergency procedures. Have your eyes checked by a physician as soon as possible.

1. Inspect the steering arm bolts. Verify that the torque is a minimum of 300 lb-ft (406 N•m).
 - **If the steering arm bolt torque is below 300 lb-ft (406 N•m):** Remove the bolts, clean all threads and install new Loctite® 680 sealant, Meritor part number 2297-K-5523. Tighten the bolts to 300-450 lb-ft (406-610 N•m).
2. Check the steering arm bolt torque every 200,000 miles (320 000 km) or 24 months, whichever comes first.

Sealed Hub Units

Inspect the truck hub unit end play every 200,000 miles (320 000 km) or 24 months, whichever comes first.

NOTE: The truck hub unit is sealed and greased, and requires no maintenance. Disassembly, lubrication or repair of the truck hub unit will void the manufacturer's warranty.

1. Park the vehicle on a level surface. Place blocks under the wheels not being serviced to prevent the vehicle from moving.
2. Raise the vehicle so that the wheels to be serviced are off the ground. Support the vehicle with safety stands.

NOTE: As the truck hub unit warms up during operation, some small amounts of grease will purge out the outboard dust seal as pressure is released from inside the truck hub unit. The grease purge is permissible if it does not exceed two grams or about one-half teaspoon. Do not replace the truck hub unit if the grease purge does not exceed two grams.

3. Remove the wheel and tire. Remove the hubcap.
4. Attach the magnetic base of a dial indicator stand to the end of the spindle. Touch the indicator stem against the face of the wheel pilot of the truck hub unit.
5. Set the dial indicator on ZERO.

NOTE: An end play reading of 0.0-inch is approved for the truck hub unit. Don't replace the unit if you obtain this reading.

6. Slightly rotate the truck hub unit in both directions while pushing INWARD until the dial indicator doesn't change. Repeat this step while pulling OUTWARD. The difference between the two readings is the end play.
 - **If the end play is greater than 0.003-inch (0.076 mm):** Recheck the torque on the inner wheel bearing nut.
7. Repeat Step 4. Record measurements greater than 0.003-inch (0.076 mm) and less than 0.009-inch (0.229 mm) in a maintenance log.
8. Check that the truck hub unit rotates smoothly.
 - **If the end play reaches 0.009-inch (0.229 mm) or the truck hub unit is very rough or noisy while rotating:** Replace the truck hub unit.

Carrier

Drive axles generate small metal wear particles at a fairly steady rate, especially during the break-in period. If these fine, but hard particles are allowed to circulate in the lubricant, along with external moisture and dirt, the internal components will wear at a much faster rate than normal.

Magnets and Magnetic Drain Plugs

Meritor front driving axles are equipped with magnetic drain plugs that have a minimum pickup capacity of 1.5 lbs (0.7 kg) of low carbon steel.

The magnetic drain plug can be reused if, after cleaning, the plug has a minimum pickup capacity of 1.5 lbs (0.7 kg) of low carbon steel.

NOTE: Inspect the magnetic drain plug each time the oil is changed. Use the correct part. Pipe plugs will leak if used as a drain plug.

5 Front Drive Steer Axles

Breather

⚠ CAUTION

Cover the breather when steam cleaning the housing to prevent water from entering the housing and contaminating the oil. Damage to components can result.

Baffle-type breathers help keep the axles free from external moisture and dirt, which can cause premature oil and component failure.

Seals

⚠ CAUTION

Always use the correct tools and procedures when replacing the seals to prevent incorrect installation and help prevent the seals from leaking.

Seals keep the lubricant in and the dirt out of a component. When they are worn or damaged, seals leak and produce low lubricant levels which may damage components.

Durable triple-lip seals, standard in Meritor axles, protect the quality and levels of the lubricant and provide superior performance.

Temperature Indicators

⚠ CAUTION

Meritor axles can operate above 190°F (88°C) without damage. However, if the oil temperature reaches 250°F (121°C), stop the vehicle immediately and check for the cause of overheating. Damage to components can result.

Many Meritor axles have a tapped hole in the housing for the installation of a lubricant temperature indicator that will help reduce the failure of axle parts from overheated oil.

Check and Adjust the Oil Level

1. Verify that the vehicle is parked on a level surface.
2. Remove the fill plug from the axle.
3. The oil level must be even with the bottom of the fill plug hole.
 - **If oil flows from the hole when the plug is loosened:**
The oil level is high. Let the oil drain to the correct level.
 - **If the oil level is below the bottom of the fill plug hole:**
Add the specified oil.
4. Install and tighten the fill plug to 35-50 lb-ft (48-67 N•m). **ⓘ**

Drain and Replace the Oil

1. Verify that the vehicle is parked on a level surface. Place a large container under the axle.
2. Remove the drain plug from the bottom of the axle. Drain and discard the oil correctly.
3. Clean, install and tighten the drain plug to 35-50 lb-ft (48-67 N•m). **ⓘ**
4. Remove the fill plug from the axle.
5. Fill the axle to the bottom of the fill plug hole with the specified oil. Allow enough time for the oil to circulate through the axle assembly.
6. Install and tighten the fill plug to 35-50 lb-ft (48-67 N•m). **ⓘ**

Lubrication

King Pin Bushings

1. Park the vehicle on a level surface. Block the wheels to prevent the vehicle from moving. Set the parking brake.
2. Verify that the tires touch the ground. Do not raise the vehicle. The full weight of the vehicle must be on the axle assembly. Figure 5.15.

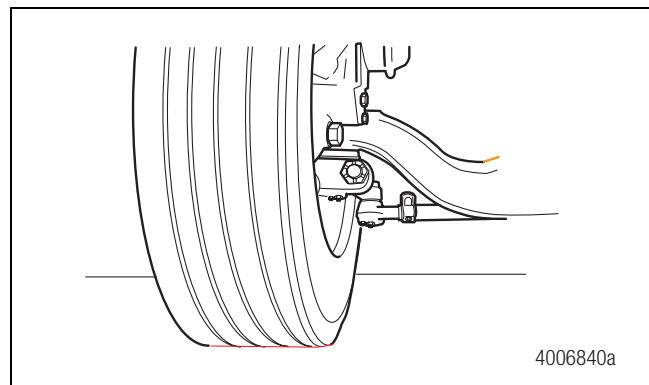

Figure 5.15

3. Clean all grease fittings before you lubricate the king pins.
4. Lubricate the king pins through the top and bottom grease fittings. Figure 5.16.

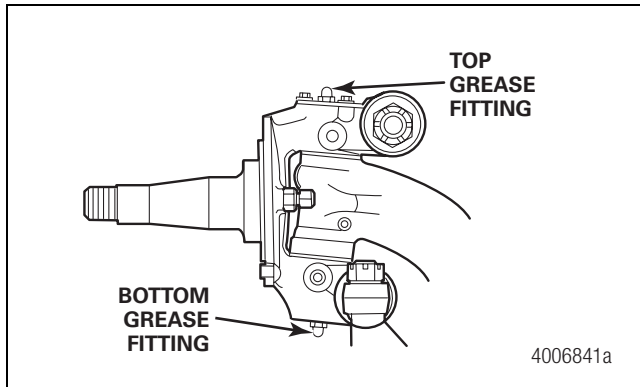

Figure 5.16

5. Apply lubricant into the top grease fitting until new grease purges from the upper shim pack. Figure 5.17.

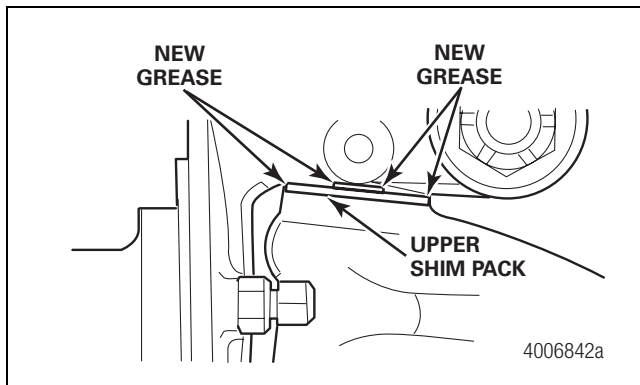

Figure 5.17

6. Apply lubricant into the bottom grease fitting until new grease appears from under the lower lip of the bearing deflector. Figure 5.18.

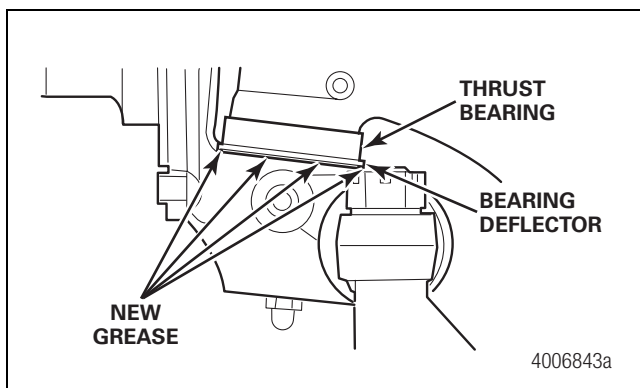

Figure 5.18

Camshaft Retainer Bushing and Cam Bushing

Pump grease until it purges through the seals. Figure 5.19.

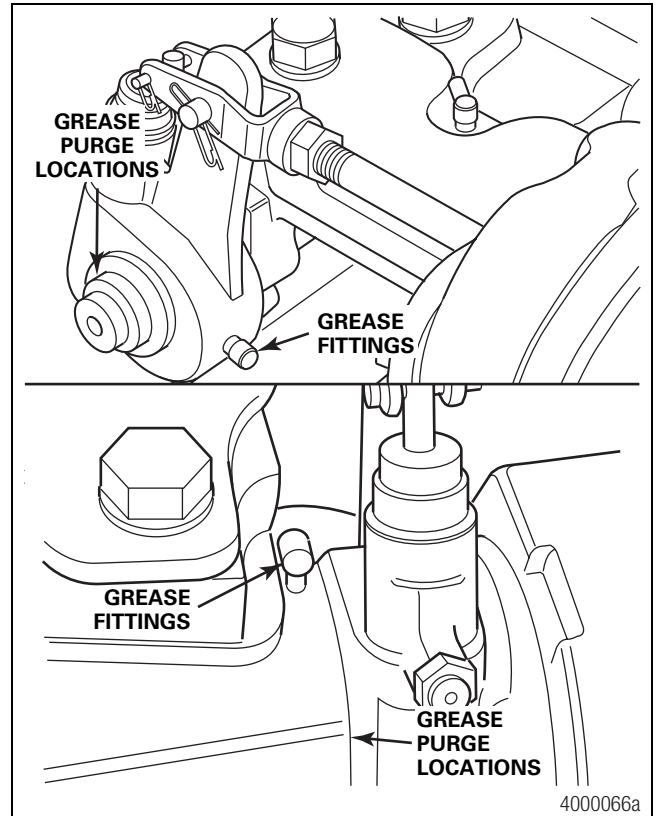

Figure 5.19

Cross Tube End Assembly

1. Check the cross tube for looseness of more than 0.060-inch (1.52 mm). Figure 5.20.

- If the cross tube is loose: Service as necessary.

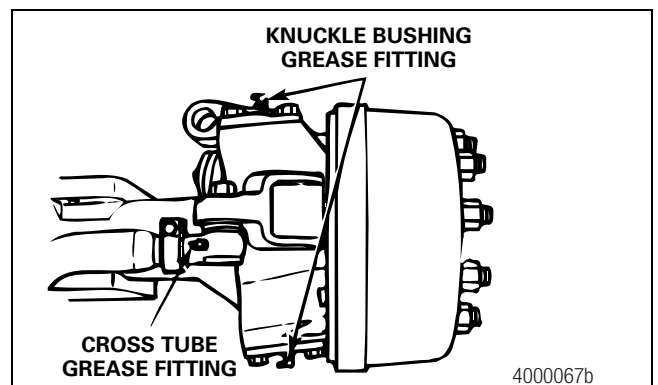

Figure 5.20

5 Front Drive Steer Axles

2. Apply the specified grease at the grease fitting on the cross tube until new grease purges from all the seals.
 - **If new grease does not purge at the seals:** Move the cross tube while applying grease at the fittings until new grease purges from all the seals.
 - **If new grease still does not purge:** Disassemble the cross tube. Inspect the grease and the components. Service as necessary.

Drive Axle Shaft Universal Joints

1. Permanently-lubricated Permalube™ joints do not have a grease fitting provided. Periodic greasing is not required for these parts. For serviceable universal joints with grease fittings, follow Step 2 and Step 3.
2. Clean all grease fittings prior to lubrication.
3. Apply the specified grease at the grease fitting on the universal joint. Apply grease until new grease purges from all the seals.
 - **If new grease does not purge at every seal:** Move the driveline while applying grease at the fittings until new grease purges at every seal.
 - **If new grease still does not purge:** Disassemble the universal joint. Inspect the grease and the components. Service as necessary.

Axle Shaft Spline and Thrust Washer

On axles with greaseable drive flanges, pump grease through the grease fitting until it purges at the axle shaft seal. Figure 5.21.

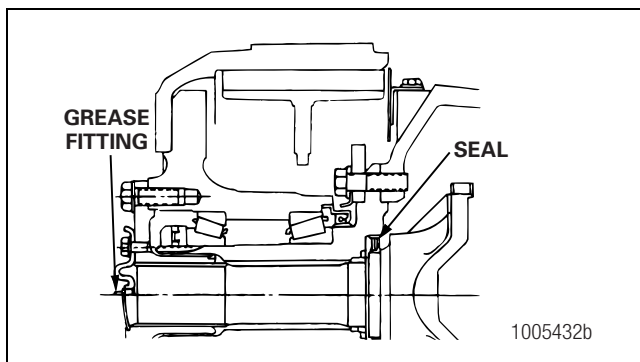

Figure 5.21

Knuckle Bushing

1. Check the knuckle for looseness. The correct end play is 0.001-0.065-inch (0.025-1.65 mm) for new axles or 0.001-0.075-inch (0.025-1.9 mm) for in-service axles. If loose, service as necessary.
2. Clean all grease fittings prior to lubrication.
3. Apply the specified grease at the grease fitting on the knuckle. Apply grease until new grease purges from all the seals. Grease the lower pin cap with the vehicle weight on the wheel end to ensure that the thrust bearing is completely greased.
 - **If new grease does not purge at the seals:** Move the knuckle while applying grease at the fittings until new grease purges at the seals.
 - **If new grease still does not purge:** Disassemble the knuckle. Inspect the grease and the components. Service as necessary.

Wheel Bearings

⚠ WARNING

Park the vehicle on a level surface. Block the wheels to prevent the vehicle from moving. Support the vehicle with safety stands. Do not work under a vehicle supported only by jacks. Jacks can slip and fall over. Serious personal injury and damage to components can result.

1. Park the vehicle on a level surface. Place blocks under the wheels not being serviced to prevent the vehicle from moving.
2. Raise the vehicle so that the wheels to be serviced are off the ground. Support the vehicle with safety stands.
3. Use the correct cleaning solvent to remove the old grease from all parts. Discard the seals. Inspect the wheel bearings for wear or damage. Replace worn or damaged bearings.
4. Use a pressure packer to force the specified grease from the large end of the cones into the cavities between the rollers and cage. Pack the hub between the bearing cups with grease to the level of the smallest diameter of the cups.
 - **If a pressure packer is not available:** Grease the bearings by hand.
5. Install the inner and outer bearing cones into the cups in the hubs. The bearing cups must be pressed tight against the shoulder in the hubs.

6. Install new wheel seals into the hubs.
7. Install the hub and the wheel and tire assembly. Install the outer wheel bearing cone into the hub. Install the adjusting nut.
8. Adjust the wheel bearings.

Tie Rod End

1. Turn the vehicle wheels straight ahead. Figure 5.22.

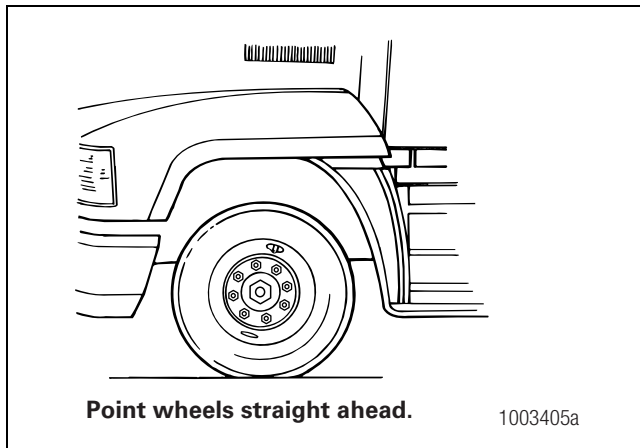

Figure 5.22

2. Wipe the grease fitting and seal and boot, with shop towels.
3. Attach either a hand or air pressure grease gun to the grease fitting. Old grease should purge from the holes near the boot crimp or bellows area, usually at three or more places. Figure 5.23.
 - **If using air pressure:** Do not exceed 150 psi (1035 kPa).

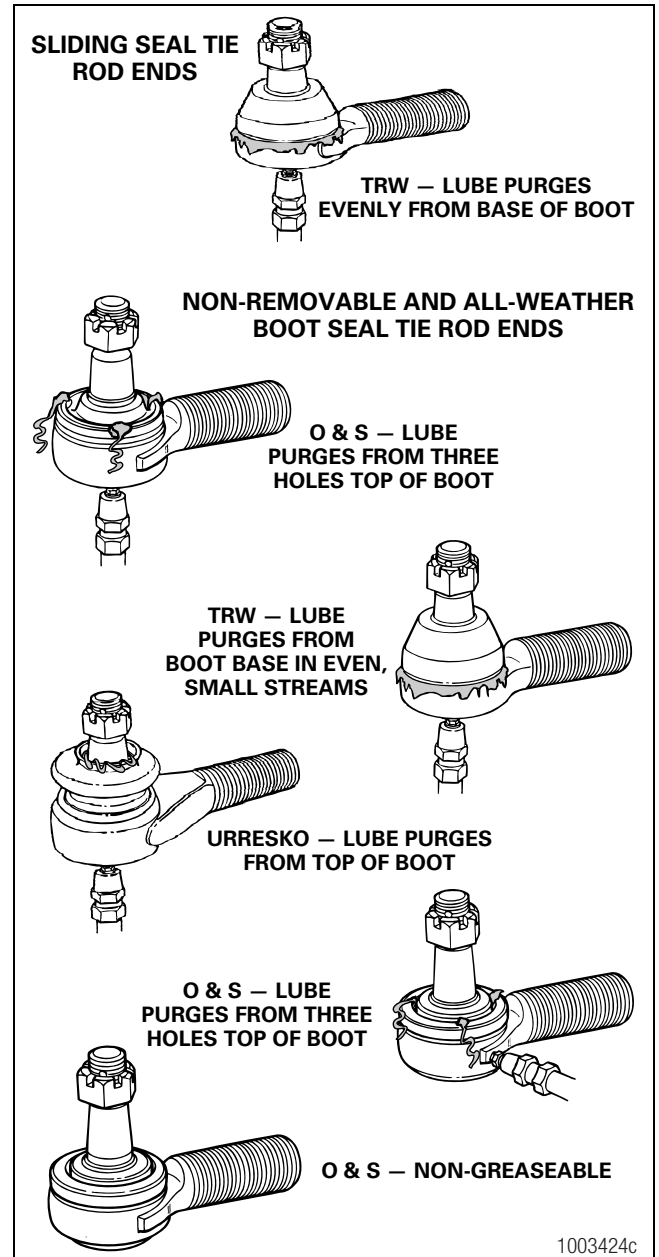

Figure 5.23

4. If the tie rod end is designed for lube service and does not accept grease, perform the following procedure.
 - A. Remove the grease fitting.
 - B. Inspect the threaded grease fitting hole in the tie rod end and remove any obstructions.
 - C. Install a new grease fitting.
 - D. Continue the lubrication procedure.
5. Apply grease until all the old grease is purged from the boot.

5 Front Drive Steer Axles

Steering Knuckle Sockets

1. Verify that the tires touch the ground. Do not raise the vehicle.
2. Clean the grease fitting prior to lubrication.
3. Lube the knuckle sockets through the grease fittings on the top and bottom knuckle caps. Figure 5.24.

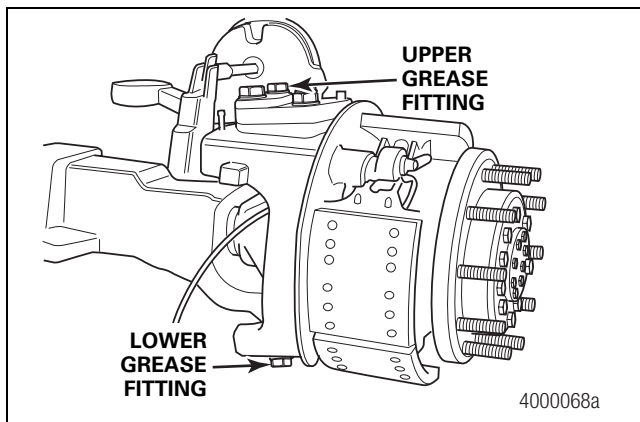

Figure 5.24

4. Force lubricant into the upper and lower knuckle sockets until the lubricant flows out between the axle housing sockets and the steering knuckle.

Lubrication Intervals and Specifications

Table AK: Front Drive Steer Axle Oil Change Intervals and Specifications

| | |
|-----------------------------|--|
| Initial Oil Change | No longer required as of January 1, 1993 |
| Check Oil Level | Every 5,000 miles (8000 km), once a month, or the fleet maintenance interval, whichever comes first* |
| Petroleum Oil Change | Every 25,000 miles (40 000 km) or annually, whichever comes first |
| Synthetic Oil Change | Every 50,000 miles (80 000 km) or annually, whichever comes first |

* For continuous heavy-duty operation, check the oil level every 1,000 miles (1600 km). Add the correct type and amount of oil as required.

Table AL: Front Drive Steer Axle Component Greasing Intervals

| Component | Greasing Intervals | Grease | Meritor Specification | NLGI Grade | Grease Classification | Outside Temperature |
|--|--|----------------------|-----------------------|------------|---|---|
| Cross Tube End Assemblies and Knuckle Bushings | 3,000 miles (4800 km) or 200 hours of operation, whichever comes first | Multi-Purpose Grease | 0-617-A or 0-617-B | 1 or 2 | Lithium 12-Hydroxy Stearate or Lithium Complex | Refer to the grease manufacturer's specifications for the temperature service limits. |
| U-Joints | | U-Joint Grease | 0-634-B | 2 | Lithium 12-Hydroxy Stearate with Molybdenum Disulfide | |

Table AM: Meritor Wheel-End Axle Greasing Intervals

| Greasing Intervals | Grease | Meritor Specification | NLGI Grade | Grease Classification | Outside Temperature |
|---|----------------------|---|------------|--|---|
| Whichever comes first: | Multi-Purpose Grease | 0-617-A (preferred) or 0-617-B (acceptable) | 1 or 2 | Lithium 12-Hydroxy Stearate or Lithium Complex | Refer to the grease manufacturer's specifications for the temperature service limits. |
| <ul style="list-style-type: none"> • Replacing seals • Relining brakes • On-Highway: 30,000 miles (48 000 km)/Once per year • On/Off Highway and Off-Highway: 15,000 miles (24 140 km)/Twice per year | | | | | |

Table AN: Lubricant Specifications

| Meritor Specification | Oil | Oil Description | Outside Temperature | | | |
|--------------------------|--------------------|-------------------|---------------------|------|------|------|
| | | | °F | | °C | |
| | | | Min. | Max. | Min. | Max. |
| O-76A | Gear Oil | GL-5, SAE 85W/140 | 10 | None | -12 | None |
| O-76D | Gear Oil | GL-5, SAE 80W/90 | -15 | None | -26 | None |
| O-76E | Gear Oil | GL-5, SAE 75W/90 | -40 | None | -40 | None |
| O-76J | Gear Oil | GL-5, SAE 75W | -40 | 35 | -40 | 2 |
| O-76L | Gear Oil | GL-5, SAE 75W/140 | -40 | None | -40 | None |
| O-76M | Full-Synthetic Oil | GL-5, SAE 75W/140 | -40 | None | -40 | None |
| O-76N | Full-Synthetic Oil | GL-5, SAE 75W/90 | -40 | None | -40 | None |

Military Specification Approval for all oils is ML-L-2105D or MIL-PRF-2105-E.

NOTE: Axle lube oil capacity is 2 gallons (7.5 liters).

Table AO: Front Drive Steer Axle Oil Capacities by Model

| Axle Model | Oil Capacity* | | Axle Model | Oil Capacity* | |
|------------|---------------|--------|------------|---------------|--------|
| | Pints | Liters | | Pints | Liters |
| FDS-75 | 13.0 | 6.2 | MX-10-120 | 20.0 | 9.0 |
| FDS-2101 | 28.0 | 13.2 | RF-21-155 | 27.9 | 13.2 |
| RF-7-120 | 15.0 | 7.0 | FDS-1800 | 28.0 | 13.2 |
| FDS-78 | 13.0 | 6.2 | MX-12-120 | 20.0 | 9.0 |
| FDS-2102 | 43.0 | 20.3 | RF-21-156 | 27.9 | 13.2 |
| RF-9-106 | 14.0 | 6.6 | FDS-1805 | 28.0 | 13.2 |
| FDS-85 | 13.0 | 6.2 | MX-14-120 | 20.0 | 9.0 |
| FDS-2107 | 43.0 | 20.3 | RF-21-160 | 43.7 | 20.7 |
| RF-9-120 | 15.0 | 7.0 | FDS-1807 | 28.0 | 13.2 |
| FDS-90 | 13.0 | 6.2 | MX-16-120 | 20.0 | 9.0 |
| FDS-2110 | 43.0 | 20.3 | RF-21-355 | 28.0 | 13.2 |
| RF-12-120 | 15.0 | 7.0 | FDS-1808 | 28.0 | 13.2 |
| FDS-93 | 13.0 | 6.2 | MX-21-160 | 43.0 | 20.0 |
| FDS-2111 | 43.0 | 20.3 | RF-22-166 | 43.0 | 20.0 |
| RF-12-125 | 15.3 | 7.2 | FDS-2100 | 28.0 | 13.2 |
| FDS-750 | 13.9 | 6.5 | RF-7-106 | 14.0 | 6.6 |
| FDS-2117 | 43.0 | 20.3 | RF-23-180 | 39.3 | 18.6 |
| RF-16-145 | 36.4 | 17.2 | MX-23-160 | 43.0 | 20.0 |
| FDS-1600 | 21.0 | 9.9 | | | |

* Oil capacities are for standard track axles that have been measured at various common drive pinion angles. The quantities listed include enough oil for both wheel ends. These oil capacities will change if the track or the drive pinion angle is different.

5 Front Drive Steer Axles

Troubleshooting

Table AP: Front Drive Steer Axle Troubleshooting

| Condition | Cause | Correction |
|---|---|---|
| Tires wear out quickly or have uneven tire tread wear. | Tires have incorrect air pressure | Adjust the air pressure in the tires. |
| | Tires out-of-balance | Balance or replace the tires. |
| | Incorrect tandem axle alignment | Align the tandem axles. |
| | Incorrect toe-in setting | Adjust the toe-in specified setting. |
| | Incorrect steering arm geometry | Service the steering system as necessary. |
| | Excessive wheel end play | Readjust the wheel bearings. |
| Vehicle is hard to steer. | Power steering system pressure low | Repair the power steering system. |
| | Steering gear linkage not assembled correctly | Assemble the steering gear correctly. |
| | Steering linkage needs lubrication | Lubricate the steering linkage. |
| | King pins binding | Replace the king pins. |
| | Incorrect steering arm geometry | Service the steering system as necessary. |
| | Caster out-of-adjustment | Adjust the caster as necessary. |
| | Tie rod ends hard to move | Replace the tie rod ends. |
| | Worn thrust bearing | Replace the thrust bearing. |
| Tie rod ends are worn and require replacement. | Tie rod ends require lubrication | Lubricate the cross tube ends. Verify that the lubrication schedule is followed. |
| | Severe operating conditions | Increase the frequency of the inspection and lubrication intervals. |
| | Damaged boot on the tie rod end | Replace the boot. |
| Bent or broken cross tube, tie rod end ball stud, steering arm or tie rod end. Component requires replacement. | Too much pressure in the power steering system; pressure exceeds vehicle manufacturer's specification | Adjust the power steering system to the specified pressure. |
| | Power steering system cut-off pressure, out-of-adjustment | Adjust the power steering system to the specified pressure. |
| | Vehicle operated under severe conditions | Verify that the vehicle is operated correctly. |
| | Add-on type of power steering system not installed correctly | Correctly install the add-on power steering system. |
| | Steering gear overtravel poppets incorrectly set or malfunctioning | Check for correct operation or adjust the overtravel of the poppets to the vehicle manufacturer's specifications. |
| | Axle stops incorrectly set | Set the axle stops to the vehicle manufacturer's specification. |

Table AP: Front Drive Steer Axle Troubleshooting

| Condition | Cause | Correction |
|---|---|--|
| Worn or broken steering ball stud | Drag link fasteners tightened higher than the vehicle manufacturer's specifications | Tighten the drag link fasteners to the specified torque. |
| | Lack of lubrication or incorrect lubricant | Lubricate the linkage with the specified lubricant. |
| | Power steering stops out-of-adjustment | Adjust the stops to the specified dimension. |
| Worn king pins and king pin bushings | Worn or missing seals and gaskets | Replace the seals and gaskets. |
| | Incorrect lubricant | Lubricate the axle with the specified lubricant. |
| | Axle not lubricated at scheduled intervals | Lubricate the axle at the scheduled intervals. |
| | Incorrect lubrication procedures | Use the correct lubrication procedures. |
| | Lubrication schedule does not match operating conditions | Change the lubrication schedule to match the operating conditions. |
| Vibration or shimmy of front axle during operation | Caster out-of-adjustment | Adjust the caster. |
| | Wheels or tires out-of-balance | Balance or replace the wheels and tires. |
| | Worn shock absorbers | Replace the shock absorbers. |

6 Front Non-Drive Steer Axles

Hazard Alert Messages

Read and observe all Warning and Caution hazard alert messages in this publication. They provide information that can help prevent serious personal injury, damage to components, or both.

⚠ WARNING

To prevent serious eye injury, always wear safe eye protection when you perform vehicle maintenance or service.

Park the vehicle on a level surface. Block the wheels to prevent the vehicle from moving. Support the vehicle with safety stands. Do not work under a vehicle supported only by jacks. Jacks can slip and fall over. Serious personal injury and damage to components can result.

How to Obtain Additional Maintenance and Service Information

Refer to the publications in Table AQ. To obtain these publications, refer to the Service Notes page on the front inside cover of this manual.

Table AQ: Publications

| Model | Manual |
|-----------------------------|----------------------|
| Front Non-Drive Steer Axles | Maintenance Manual 2 |

Description

The descriptions and procedures contained in this maintenance manual are applicable to all Meritor front non-drive steer axles.

Meritor front non-drive steer axles are available in conventional, Easy Steer Plus™ and MFS designs. Axle steering components include steering arm, tie rod cross tube assembly, tie rod arm, tie rod end and knuckle. Figure 6.1 and Figure 6.2.

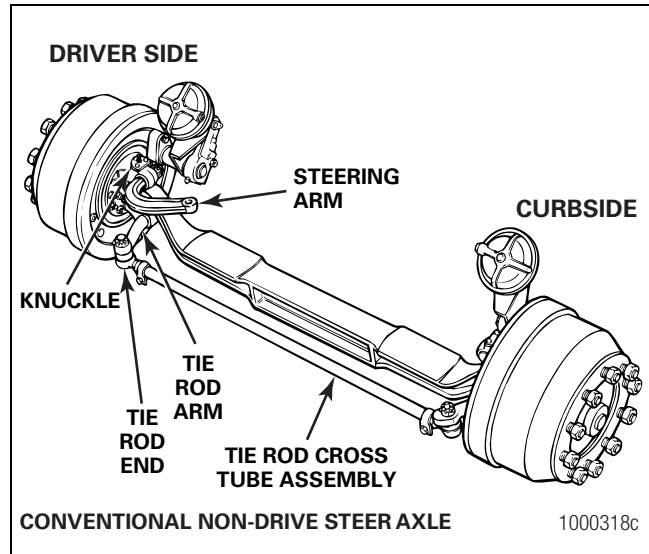

Figure 6.1

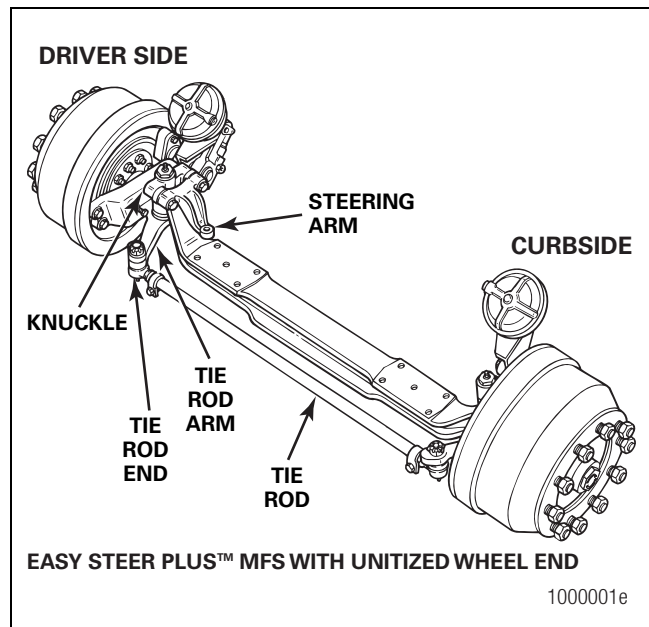

Figure 6.2

Identification

The axle build information and assembly date for Meritor front non-drive steer axles are on the axle identification tag. Figure 6.3.

The identification tag is fastened to the center of the beam at the front surface. The axle assembly date is located in either the lower right-hand or left-hand corner of the tag.

The Julian method is used to indicate the axle assembly date and is shown in Figure 6.3. The first two digits indicate the year, and the last three digits indicate the day of the year.

In the following example, 01 is the year 2001 and 327 refers to November 22.

To identify the model number, refer to the identification plate on the front of the beam. Use the complete model number to order parts.

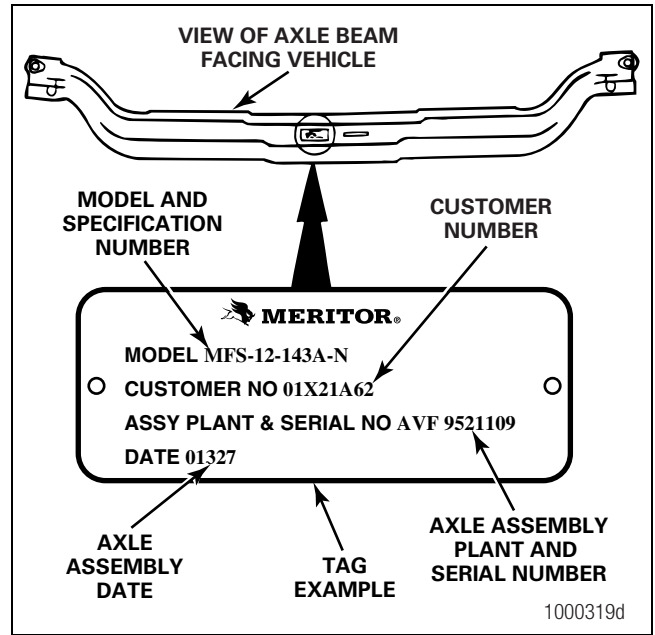

Figure 6.3

Model Nomenclature

Refer to Figure 6.4 for an explanation of non-MFS front non-drive model numbers. For an explanation of MFS model numbers, refer to Figure 6.5.

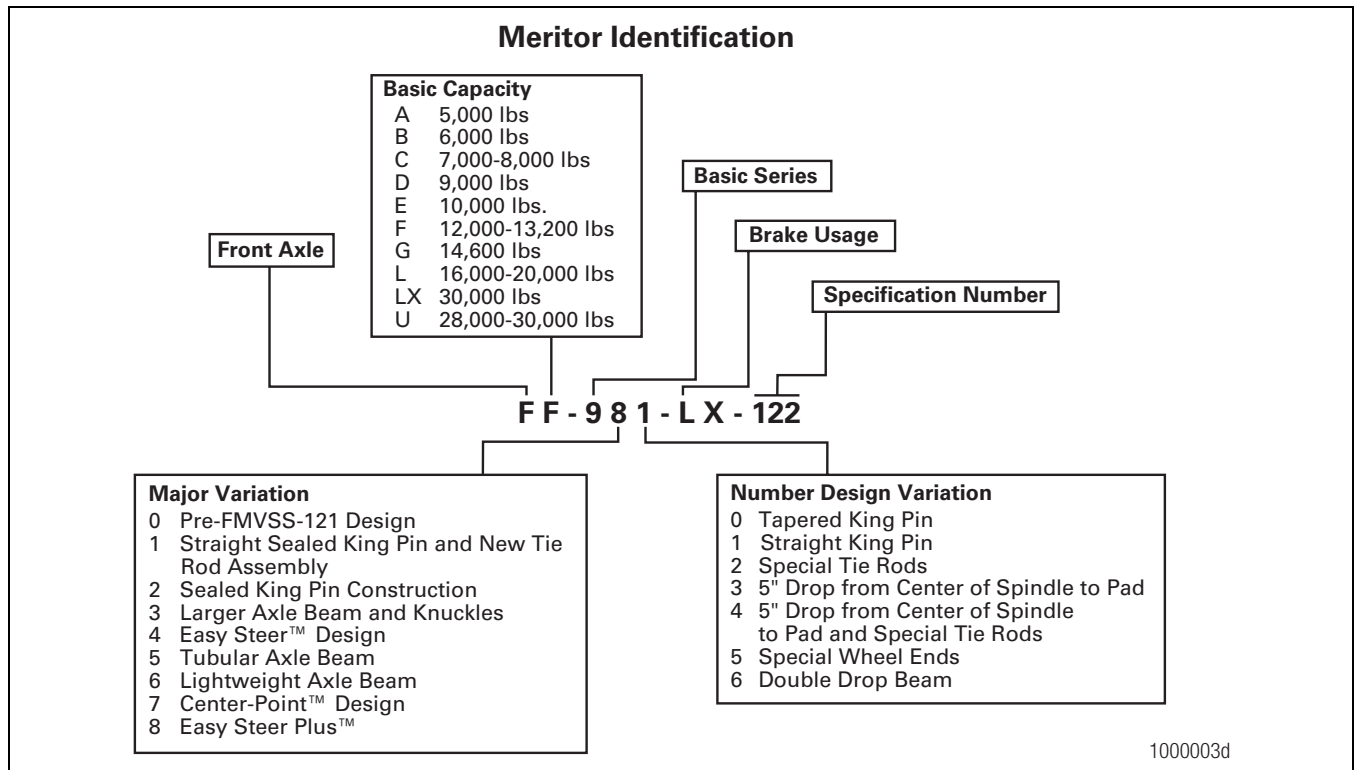

Figure 6.4

6 Front Non-Drive Steer Axles

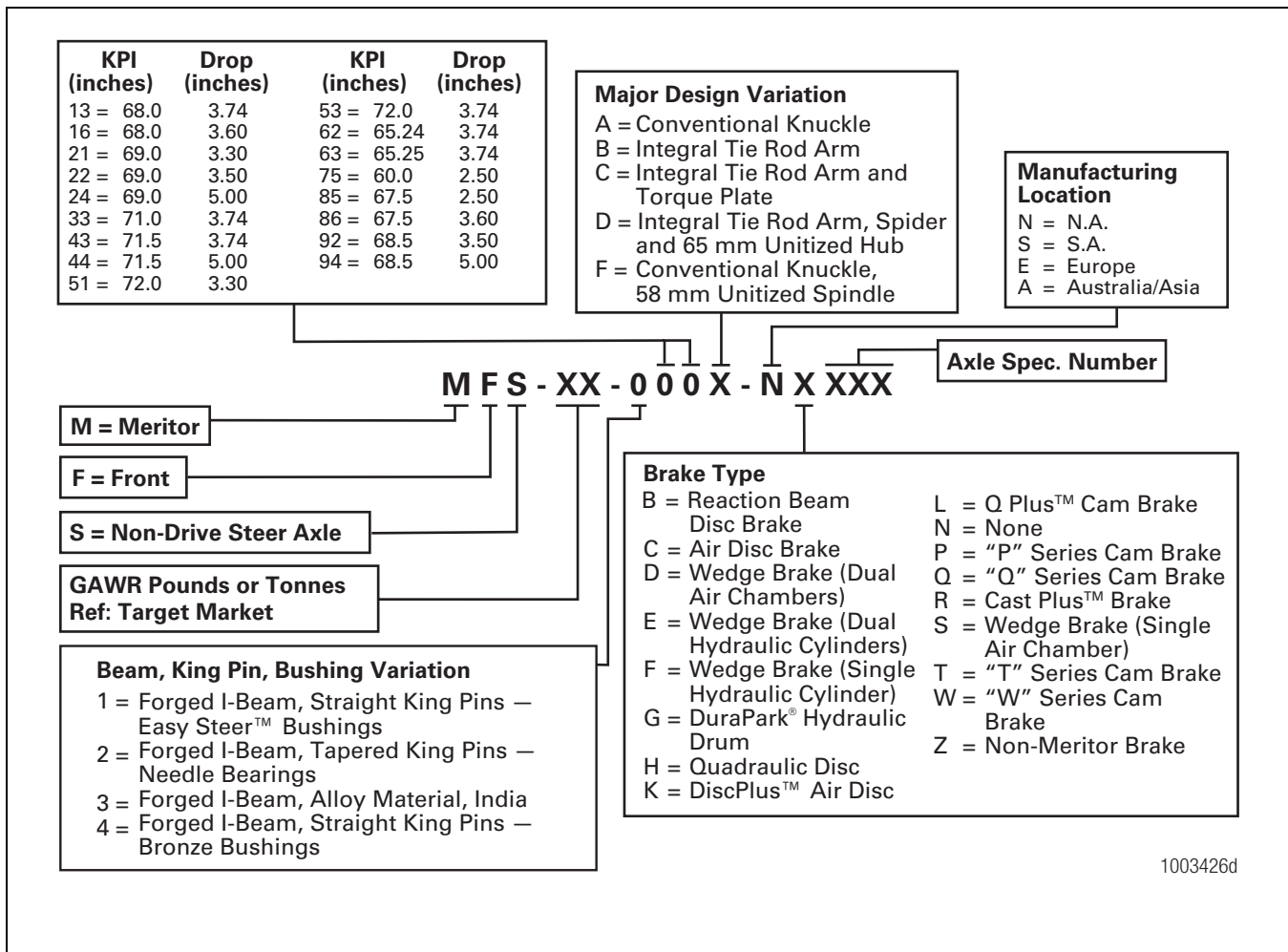

Figure 6.5

Inspection

Parts

Fasteners

1. Verify that all the fasteners are tightened to the specified torque.
2. Use a torque wrench to check the torque. As soon as the fastener starts to move, record the torque. Correct if necessary.
3. Replace any worn or damaged fasteners.

Wear and Damage

Inspect parts of the axle for wear and damage. Look for bent or cracked parts. Replace all worn or damaged parts.

Pivot Points

Verify that the pivot points are not loose. Verify that the pivot points are lubricated.

Operation

Verify that all the parts move smoothly through the complete turning radius.

Tire Wear

Inspect the tires for wear patterns that indicate suspension damage or misalignment. Correct if necessary.

Steering Arm Bolts

Check the torque on all bolt-on steering arm bolts every 200,000 miles (320 000 km).

Draw Key Nuts

Tighten the draw key nuts to 30-45 lb-ft (41-61 N•m) at the following intervals. Figure 6.6. 

- After the first 6,000 miles (10 000 km) of new vehicle operation
- Every 36,000 miles (58 000 km) of operation

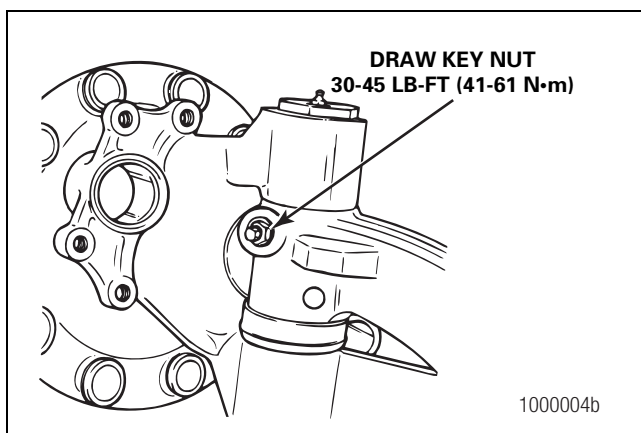

Figure 6.6

Steering Knuckle Vertical End Play

Axles with Conventional Wheel Ends

1. Park the vehicle on a level surface. Block the wheels to prevent the vehicle from moving.
2. Use a jack to raise the vehicle until the front wheels are off the ground. Support the front axle with safety stands.
3. Install a dial indicator with the base on the I-beam and the tip on the top knuckle cap. Figure 6.7.

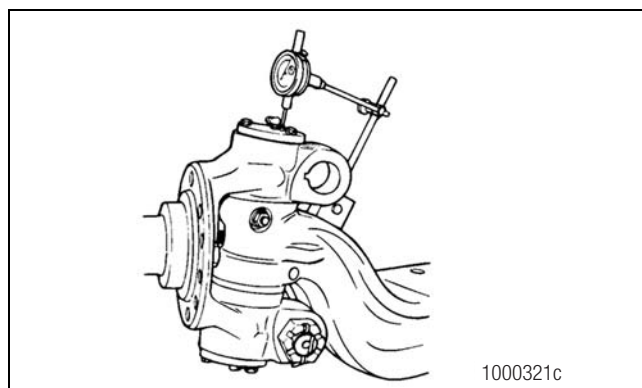

Figure 6.7

4. Place a pry bar between the boss for the tie rod arm and the I-beam. Push the knuckle to the BOTTOM of vertical travel. Figure 6.8.

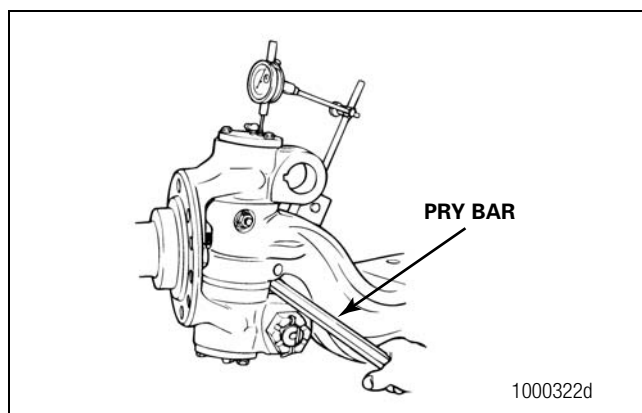

Figure 6.8

5. Set the dial indicator on ZERO.
6. Use the pry bar to push the knuckle UPWARD. Record the reading on the dial indicator.
 - **If the reading is ZERO:** Remove the knuckle. Remove the shims from the shim pack. Refer to Maintenance Manual 2, Front Non-Drive Steer Axles, for more information.
 - **If the reading is more than the correct end play specifications shown in the table below:** Remove the knuckle. Add shims to the shim pack. Refer to Maintenance Manual 2, Front Non-Drive Steer Axles, for more information.

Table AR: End Play Specifications

| | |
|-------------------------|-----------------------------------|
| New or Rebuilt | 0.001-0.010-inch (0.025-0.254 mm) |
| In-Service Axles | 0.001-0.030-inch (0.025-0.762 mm) |

6 Front Non-Drive Steer Axles

Axles with Unitized Wheel Ends

1. Park the vehicle on a level surface. Block the wheels to prevent the vehicle from moving. Set the parking brake.
2. Use a jack to raise the vehicle until the front wheels are off the ground. Support the front axle with safety stands.
3. Install a dial indicator for each side of the axle beam.

Curbside Knuckle

- A. Turn the wheels STRAIGHT ahead. Install the dial base onto the axle beam.
- B. Place the dial indicator tip onto the upper king pin cap.
- C. Place a jack and a wood block, with a hole that allows clearance for the lower king pin grease fitting, under the lower king pin cap area. Figure 6.9.

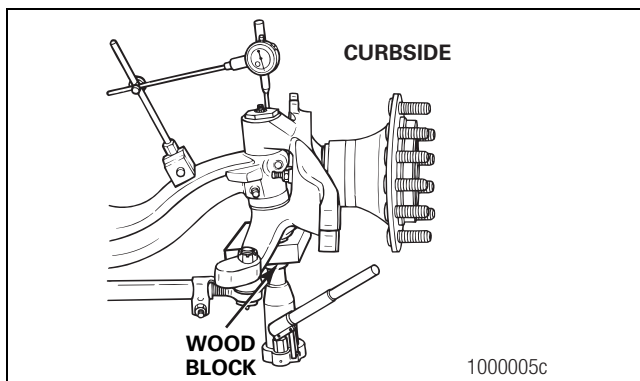

Figure 6.9

- D. Set the dial indicator to ZERO.
- E. Raise the jack until you start to lift the axle beam off the safety stands. Measure and record the dial indicator reading.
- F. Lower the jack.

Driver-Side Knuckle

- A. To check the driver-side knuckle, turn the wheels STRAIGHT ahead.
- B. Install a dial indicator with the base onto the steering arm.

NOTE: The wood block should have a hole that allows clearance for the lower king pin grease fitting.

- C. Place a jack and a wood block under the lower king pin cap area.

- D. Place the dial indicator tip onto the exposed king pin top. Set the dial indicator to ZERO.
- E. Move the jack up. Measure and record the dial indicator reading. Lower the jack.

Alternate Method to Measure End Play

- A. As an alternative method to measure end play, turn the wheels to the RIGHT for a curbside knuckle or LEFT for a driver-side knuckle measurement.
 - B. Place a pry bar between the tie rod arm and the axle beam. Figure 6.10.
 - C. Set the dial indicator to ZERO.
 - D. Lift the knuckle UPWARD using a pry bar. Record the reading on the dial indicator.
4. Compare the reading you obtained with the end play specifications below.

- **If the reading is ZERO:** Remove the knuckle. Remove shims from the shim pack. Refer to Maintenance Manual 2, Front Non-Drive Steer Axles, for more information.
- **If the reading is more than the correct end play specifications:** Remove the knuckle. Add shims to the shim pack. Refer to Maintenance Manual 2, Front Non-Drive Steer Axles, for more information.

Table AS: End Play Specifications

| | |
|------------------|-----------------------------------|
| New or Rebuilt | 0.001-0.010-inch (0.025-0.254 mm) |
| In-Service Axles | 0.001-0.030-inch (0.025-0.762 mm) |

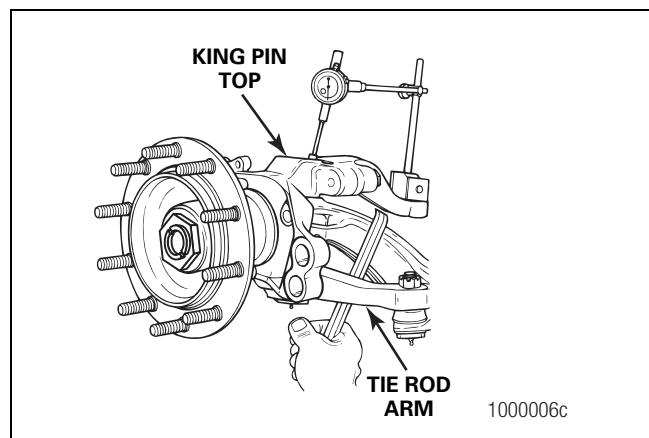

Figure 6.10

Upper and Lower King Pin Bushings

Wheel-to-Hub Mounting

To help determine the cause of movement and looseness, first check the wheel-to-hub mounting.

1. Verify that the wheel is mounted correctly and all wheel-end fasteners and hardware are secure.
2. Apply the service brake to lock the hub and spindle assembly together.
 - **If movement is detected:** The king pin or king pin bushings are most likely worn.
 - **If applying the service brake eliminates the movement:** Proceed to Detailed Inspection to determine the unitized wheel-end hub end play.

Axles with Conventional and Unitized Wheel Ends

1. Park the vehicle on a level surface. Block the wheels to prevent the vehicle from moving. Set the parking brake.
2. Use a jack to raise the vehicle until the front wheels are off the ground. Support the front axle with safety stands.
3. Check the upper king pin bushing for wear. Install a dial indicator with the base on the I-beam and the tip against the side of the top of the knuckle. Figure 6.11 and Figure 6.12.

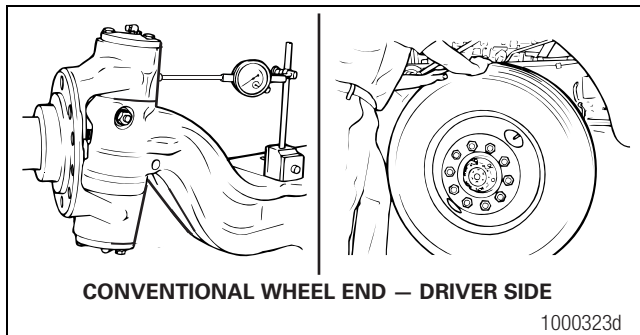

Figure 6.11

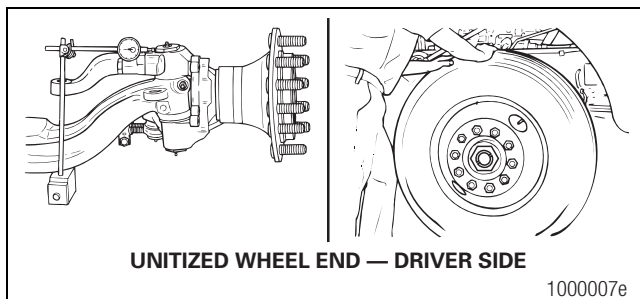

Figure 6.12

4. Set the dial indicator to ZERO.
5. Move the top of the tire side-to-side TOWARD and AWAY from the vehicle.
 - **If the indicator moves a total of 0.010-inch (0.254 mm):** The upper bushing is worn or damaged. Replace both bushings in the knuckle. Refer to Maintenance Manual 2, Front Non-Drive Steer Axles, for more information. Figure 6.11 and Figure 6.12.
6. Check the lower king pin bushing. Install a dial indicator so that the base is on the I-beam and that the tip is against the side of the bottom of the knuckle. Figure 6.13 and Figure 6.14.

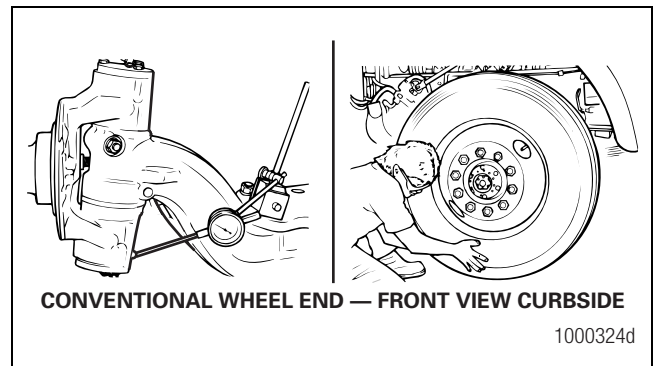

Figure 6.13

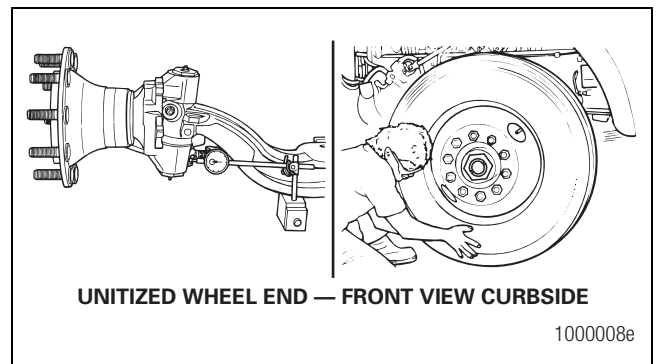

Figure 6.14

7. Set the dial indicator to ZERO.
8. Move the bottom of the tire side-to-side TOWARD and AWAY from the vehicle.
 - **If the dial indicator moves a total of 0.010-inch (0.254 mm):** The lower bushing is worn or damaged. Replace both bushings in the knuckle. Refer to Maintenance Manual 2, Front Non-Drive Steer Axles, for more information. Figure 6.13 and Figure 6.14.

6 Front Non-Drive Steer Axles

Unitized Wheel End

The unitized wheel end is sealed and greased for life and does not require lubrication. If you disassemble, or attempt to repair or lubricate a unitized wheel-end assembly, you will void Meritor's warranty. The basic and detailed inspection procedures provided in this manual do not instruct you to disassemble the unitized wheel end.

Wheel-to-Hub Mounting

To help determine the cause of movement and looseness, first check the wheel-to-hub mounting.

1. Verify that the wheel is mounted correctly and all wheel-end fasteners and hardware are tightened to the correct specification.
2. Apply the service brake to lock the hub and spindle assembly together.
 - **If you detect movement or looseness:** The king pin or king pin bushings are most likely worn.
 - **If applying the service brake eliminates the movement:** Proceed to the detailed inspection procedure in this section to determine the unitized wheel-end hub end play.

Basic Inspection

After the initial 200,000-mile (321 800 km) detailed inspection, perform a basic inspection at each scheduled preventive maintenance interval, not to exceed 50,000-mile (80 467 km) intervals.

If the Vehicle is Equipped with ABS on the Steer Axle

1. Park the vehicle on a level surface. Block the wheels to prevent the vehicle from moving.
2. Raise the vehicle so that the front wheels are off the ground. Support the vehicle with safety stands. Do not use a jack to support the vehicle.
3. Visually inspect the unitized wheel end as you rotate the tire and unitized wheel-end assembly. Verify that it rotates smoothly and without noise. While rotating the wheel, grasp the brake chamber to feel for unitized wheel-end hub vibration.
 - **If the tire and unitized wheel-end assembly does not rotate smoothly, or you hear noise or feel wheel-end hub vibration during rotation:** Replace the unitized wheel-end hub. Refer to Maintenance Manual 2, Front Non-Drive Steer Axles, for the procedures.
 - **If the wheel end rotates smoothly:** Proceed to Step 4.

4. Grasp the tire and wheel-end assembly at the 9 and 3 o'clock positions. Check for vertical and horizontal movement. With your hands, apply approximately 50 lb (23 kg) of force to the assembly. You should not feel or see any looseness or movement.
 - **If you feel or see any movement or looseness in the tire and wheel-end assembly:** Perform a detailed inspection to determine the cause of the movement, such as worn king pin bushings or pins; wheel-to-hub-mounting end play; unitized wheel-end hub end play; or a combination of them all. To determine unitized wheel-end hub end play, refer to the detailed inspection procedure in this section.

If other front axle components, such as king pin bushings, require inspection or service, refer to the appropriate procedures in this manual.

Detailed Inspection

Perform detailed inspections after the initial 200,000 miles (321 800 km) of operation and after every additional 200,000 miles (321 800 km) of operation thereafter.

1. Park the vehicle on a level surface. Block the wheels to prevent the vehicle from moving.
2. Remove the hubcap. The outboard and inboard seals may purge small amounts of grease that are visible during inspection. Figure 6.15. This is a normal occurrence.

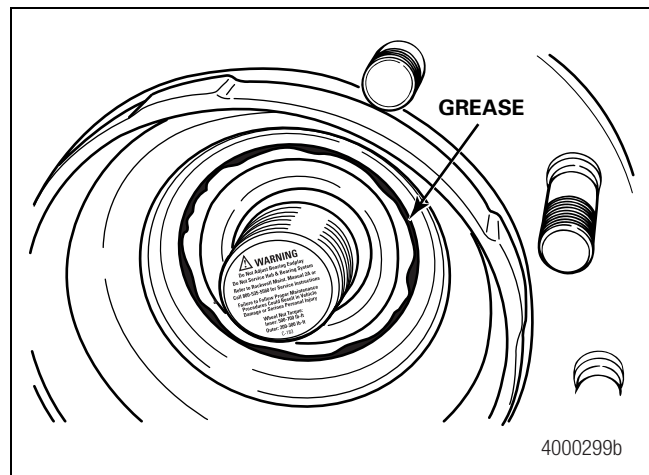

Figure 6.15

3. Raise the vehicle so that the front wheels are off the ground. Support the vehicle with safety stands. Do not use a jack to support the vehicle.

4. Verify that the unitized wheel end rotates smoothly and without noise. While rotating the wheel, grasp the brake chamber to feel for unitized wheel-end hub vibration.
 - **If the tire and unitized wheel-end assembly does not rotate smoothly, or you hear noise or feel wheel-end hub vibration during rotation:** Replace the unitized wheel-end hub.
 - **If the wheel end rotates smoothly:** Proceed to Step 5.
5. Remove the wheel and drum. Attach the magnetic base of a dial indicator onto the end of the spindle. Figure 6.16. Touch the indicator stem perpendicular against the unitized wheel end's mounting face.

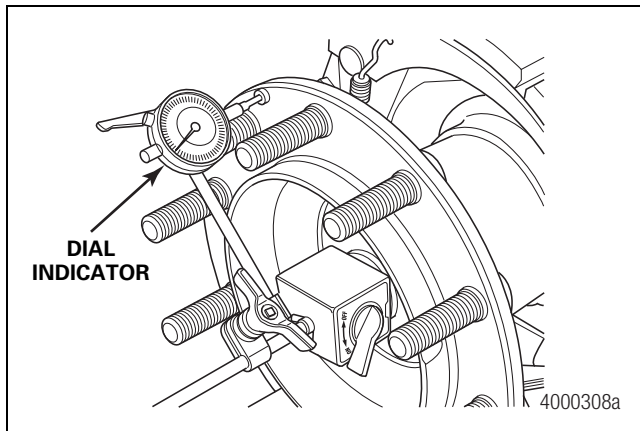





Figure 6.16

6. Set the dial indicator to ZERO. Do not rotate the wheel end. Place your hands at the 9 and 3 o'clock positions.
7. Push the unitized wheel end straight IN. Note the reading. Pull the unitized wheel end straight OUT. Note the reading.
 - **If the total movement of the dial indicator is less than 0.003-inch (0.08 mm):** Inspection is complete. Return the vehicle to service.
 - **If the total movement of the dial indicator is 0.003-inch (0.08 mm) or greater:** Remove the outer bearing nut and tabbed washer. Tighten the inner wheel bearing nut to 500-700 lb-ft (679-949 N•m) while rotating the unitized wheel end a minimum of five rotations. 

NOTE: The inner wheel bearing nut and the outer wheel bearing nut are identical, but the torque values are different.

8. Install the tabbed washer and outer wheel bearing nut onto the spindle.
 - For 1-1/8-inch (28.6 mm) wheel bearing nuts used on MFS-06, MFS-07 and MFS-08 Series axles: Tighten to 150-225 lb-ft (203-305 N•m). 
 - For other series axles: Tighten the outer wheel bearing nut to 200-300 lb-ft (272-408 N•m). 
9. Reattach the dial indicator. Set the dial indicator to ZERO. Do not rotate the wheel end. Place your hands at the 9 and 3 o'clock positions.
10. Push the unitized wheel end straight IN. Note the reading. Pull the unitized wheel end straight OUT. Note the reading.

- **If the total movement of the dial indicator is greater than 0.003-inch (0.08 mm), but less than 0.006-inch (0.15 mm):** Record the measurement in a maintenance log, and perform a basic inspection at the next regularly-scheduled maintenance interval, or not to exceed 50,000 miles (80 467 km), whichever comes first.

After you've taken the measurement, bend the parts of the tabbed washer that protrude over the flats of the outer wheel bearing nut and the inner wheel bearing nut. Bend the washer a minimum of one flat edge to each nut. Inspection is complete. Return the vehicle to service.

- **If the total movement of the dial indicator is 0.006-inch (0.15 mm) or greater:** Replace the unitized wheel-end hub.

Tie Rod and Cross Tube Assembly

NOTE: Do not grease the tie rod assembly before you perform the inspection.

You may not be able to detect loose or worn tie rod ends during operation. Under normal operating conditions, wear occurs over time. The preload bearings inside each tie rod end provide less resistance, which can affect steering control, front tire wear, and other axle components.

Regularly-scheduled inspection and maintenance helps to minimize the effects of tie rod end wear on the vehicle. Refer to Table AT and Table AU in this section for inspection intervals. Figure 6.17.

6 Front Non-Drive Steer Axles

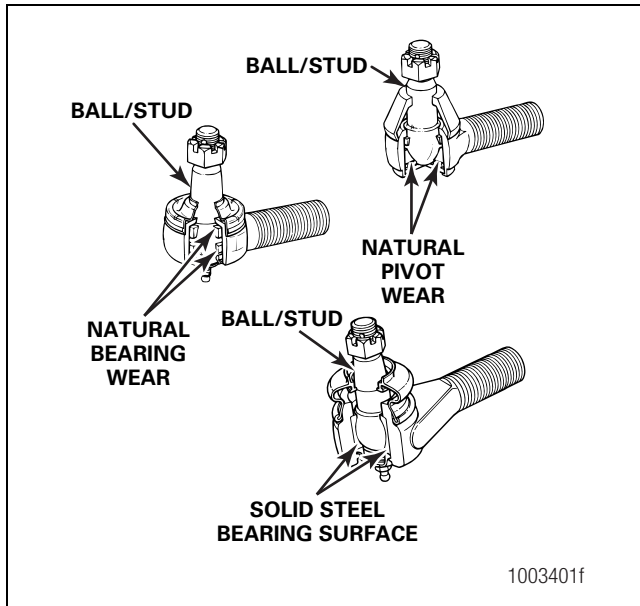

Figure 6.17

1. Park the vehicle on a level surface with the wheels STRAIGHT. Block the wheels to prevent the vehicle from moving. Set the parking brake. Figure 6.18.

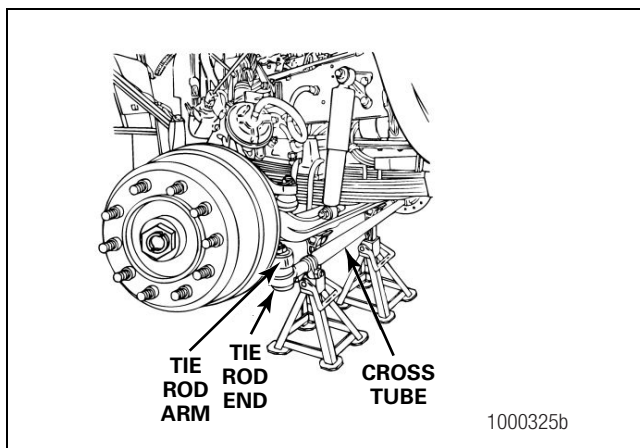

Figure 6.18

2. Raise the vehicle so that the front wheels are off the ground. Support the vehicle with safety stands. Do not use a jack to support the vehicle.
3. With the engine off, turn the wheels from full left to full right. Return to the straight-ahead position. This step will require more force for vehicles with the power steering off.

4. Check the tie rod boot for cracks, tears or other damage. Also check the boot seals for damage. Replace the entire tie rod end if the boot is damaged or missing. Figure 6.19.

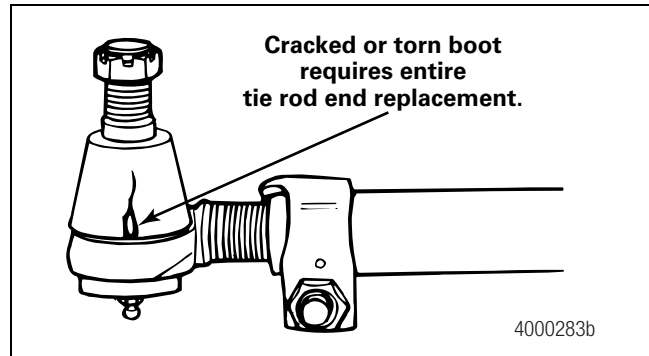

Figure 6.19

⚠ WARNING

Verify that a cotter pin is installed through the tie rod end, and the tie rod end nut is tightened to the correct torque specification. Replace a missing cotter pin and tighten a loose tie rod end nut. A missing cotter pin or loose tie rod end nut can cause loss of steering control. Serious personal injury and damage to components can result.

5. Check that the tie rod nut is installed and secured with a cotter pin.
 - **If the cotter pin is missing:** Tighten the tie rod end nut to the correct specification. Install a new cotter pin. Always tighten the tie rod nut to the specified torque when setting the cotter pin. Do not back-off the nut to insert the cotter pin. Figure 6.20.

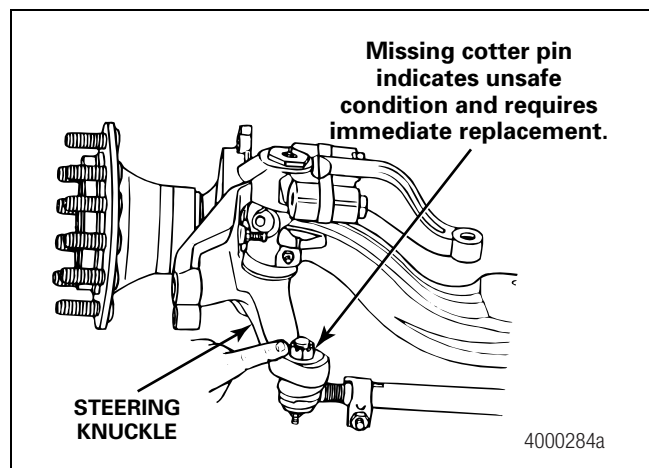

Figure 6.20

- Check that the tie rod end is threaded correctly into the cross tube and installed deeper than the end of the cross tube slot. The tie rod end must be visible the entire length of the cross tube slot. Figure 6.21.

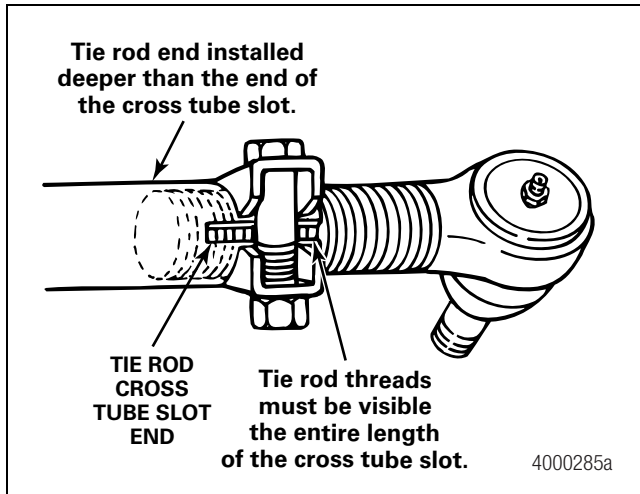

Figure 6.21

- Check that the grease fittings are installed. Replace a damaged grease fitting.
 - If the tie rod ends are non-greaseable: Do not install a grease fitting. Figure 6.22.

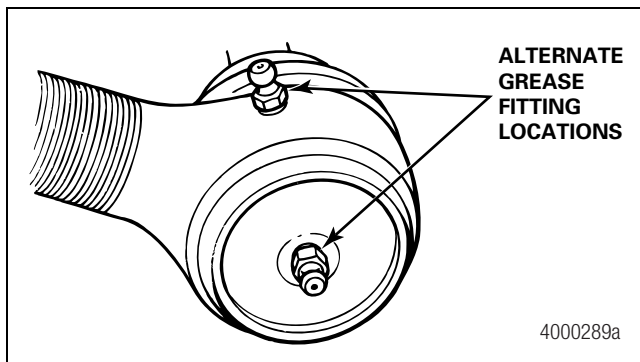

Figure 6.22

- By hand or using a pipe wrench with jaw protectors to avoid gouging the cross tube, rotate the cross tube toward the front of the vehicle and then toward the rear. After rotating, center the cross tube between the stop positions.
 - If the cross tube will not rotate in either direction: Replace both tie rod ends.

- Position yourself directly below the ball stud socket. Using both hands, grasp the assembly end as close to the socket as possible, no more than 6-inches (152.4 mm) from the end.

⚠ CAUTION

Only use your hands to check for movement or looseness of the tie rod assembly. Do not use a crow bar, pickle fork or two-by-four. Do not apply pressure or force to the tie rod assembly ends or joints. Do not rock the tires with the vehicle on the ground or with the wheels raised. Damage to components can result.

- Apply hand pressure of approximately 100 lbs (45.4 kg) in a vertical PUSH and PULL motion several times. Check for any movement or looseness at both tie rod ends. Figure 6.23.

- If there is any movement in the tie rod assembly: Replace both tie rod ends.

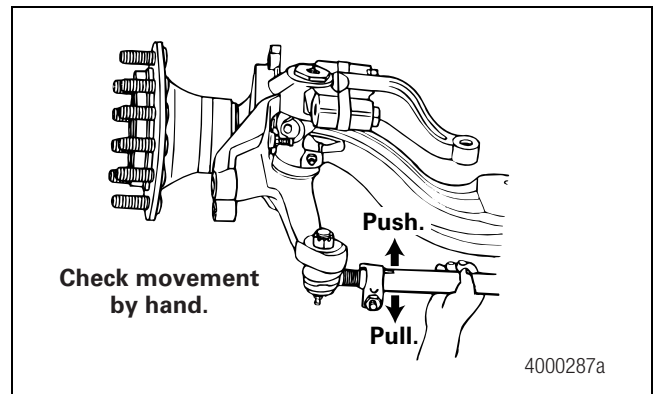

Figure 6.23

⚠ CAUTION

Replace bent or damaged cross tubes with original equipment parts of the same length, diameter and threads. Do not attempt to straighten a bent cross tube. Damage to components can result.

- Inspect the cross tube and clamps for damage. Figure 6.24.
 - If the cross tube is bent or cracked: Replace it. Use original equipment parts of the same length, diameter and threads.
 - If the clamps are damaged: Replace them.
 - If either clamp has become welded to the cross tube: Replace the entire cross tube assembly. Use original equipment parts of the same length, diameter and threads.

6 Front Non-Drive Steer Axles

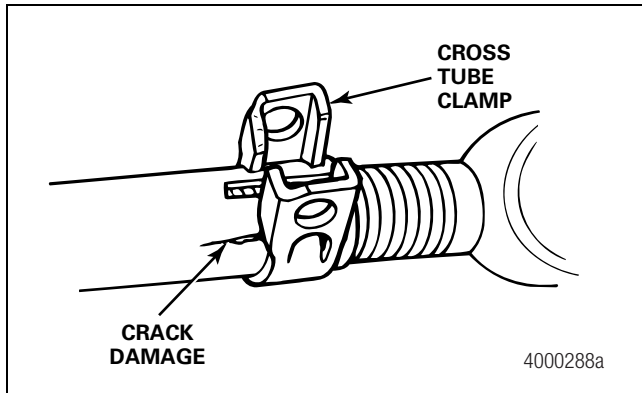

Figure 6.24

Department of Transportation Roadside Tie Rod Assembly Replacement Criteria

When the roadside check indicates tie rod movement of 0.125-inch (3 mm) or more, immediately remove the vehicle from service to replace the tie rod. Figure 6.23.

- **If the roadside check is less than 0.125-inch (3 mm) tie rod end movement:** The vehicle does not need to be immediately removed from a service run. Schedule a major out-of-service inspection and maintenance as soon as possible.

Lubrication

Tie Rod End

⚠ WARNING

Park the vehicle on a level surface. Block the wheels to prevent the vehicle from moving. Support the vehicle with safety stands. Do not work under a vehicle supported only by jacks. Jacks can slip and fall over. Serious personal injury and damage to components can result.

This procedure refers to all tie rod ends on Meritor non-drive steer axles.

1. Park the vehicle on a level surface. Block the wheels to prevent the vehicle from moving. Set the parking brake.
2. Turn the vehicle wheels to the STRAIGHT position. Figure 6.25.

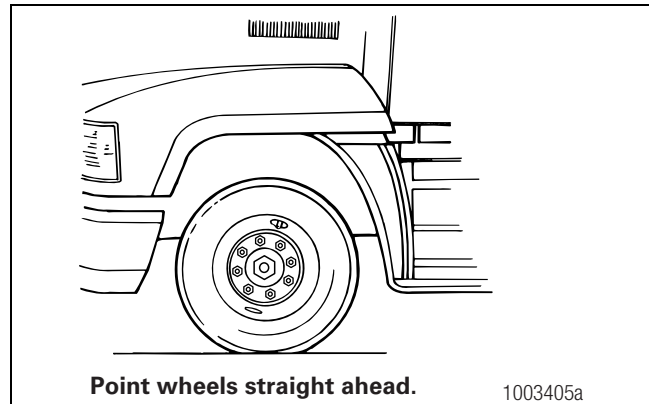

Figure 6.25

3. Wipe the grease fitting, seal and boot clean with shop towels. Figure 6.26.

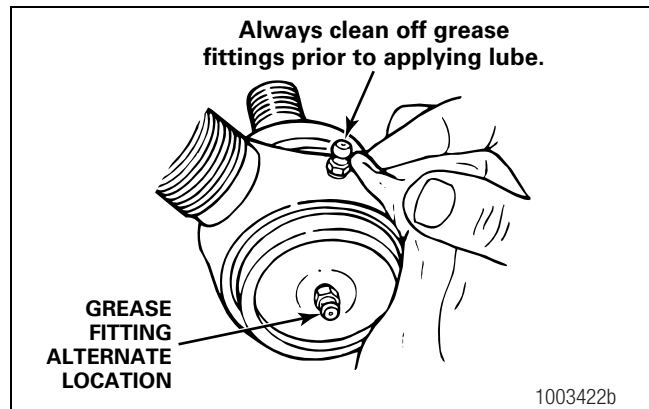

Figure 6.26

4. Attach either a hand or air pressure grease gun to the grease fitting. Figure 6.27. If using air pressure, do not exceed 150 psi (1035 kPa).

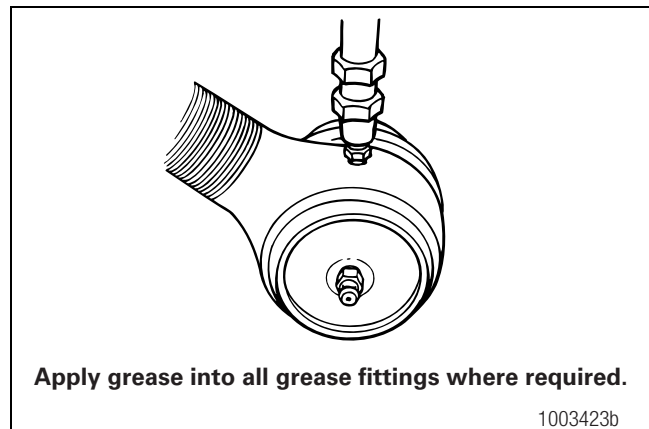

Figure 6.27

5. Apply grease into the grease fitting. Discolored old grease should come out of the purge holes near the boot crimp or bellows area, typically three or more places. Figure 6.28.

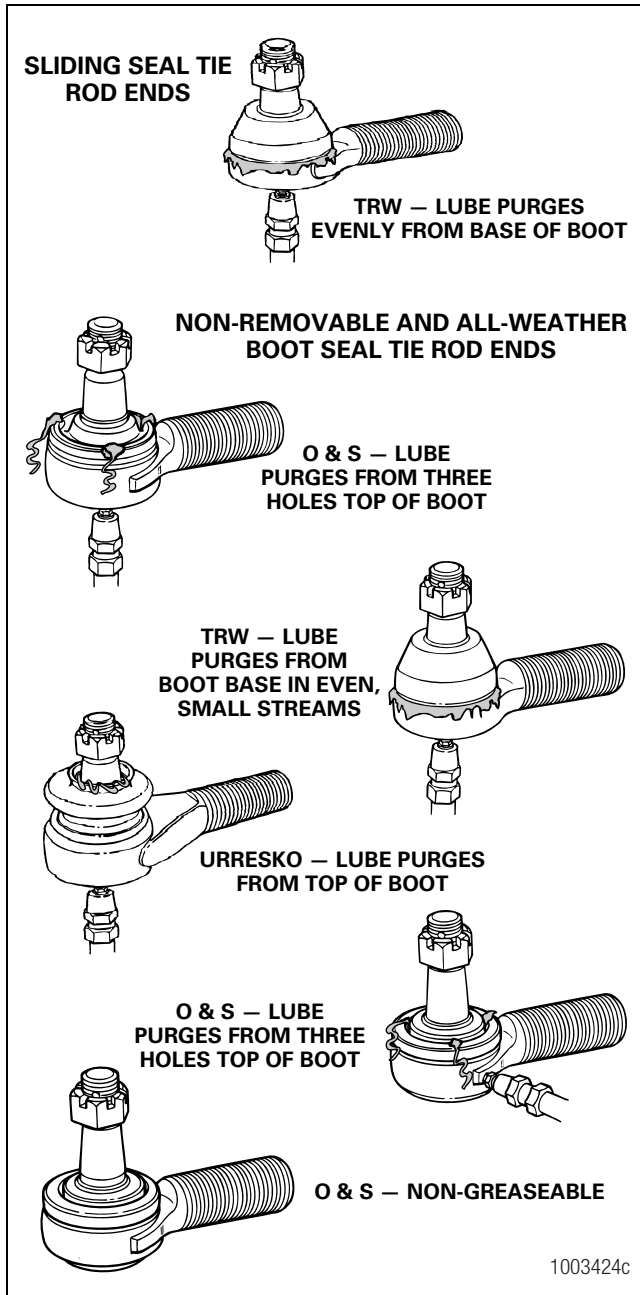

Figure 6.28

6. If the tie rod end is designed for lube service and it does not accept grease, perform the following procedure.
 - A. Remove the grease fitting.
 - B. Inspect the threaded grease fitting hole in the tie rod end and remove any obstructions.
 - C. Install a new grease fitting.
 - D. Continue the lubrication procedure.
7. Apply grease until all old grease is purged from the boot.

King Pin Bushings

Axles with Conventional Wheel Ends

1. Park the vehicle on a level surface. Block the wheels to prevent the vehicle from moving. Set the parking brake.
2. Verify that the tires touch the ground. Do not raise the vehicle. The full weight of the vehicle must be on the axle assembly. Figure 6.29.

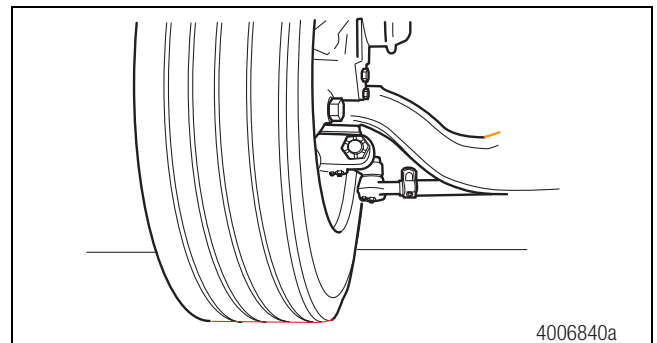

Figure 6.29

3. Clean all grease fittings before you lubricate the king pins.
4. Lubricate the king pins through the top and bottom grease fittings. Figure 6.30.

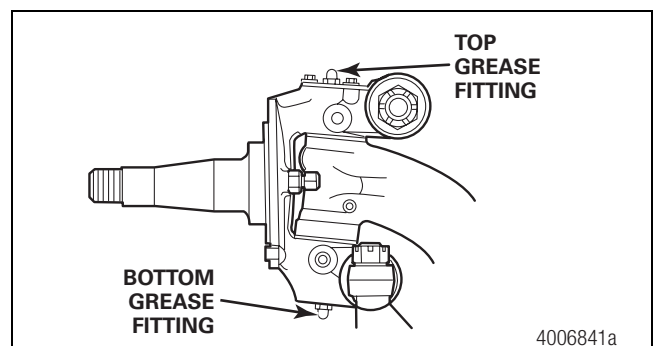

Figure 6.30

6 Front Non-Drive Steer Axles

5. Apply lubricant into the top grease fitting until new grease purges from the upper shim pack. Figure 6.31.

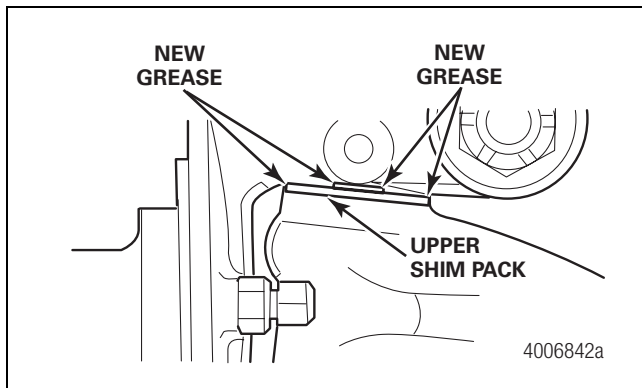

Figure 6.31

6. Apply lubricant into the bottom grease fitting until new grease appears from under the lower lip of the bearing deflector. Figure 6.32.

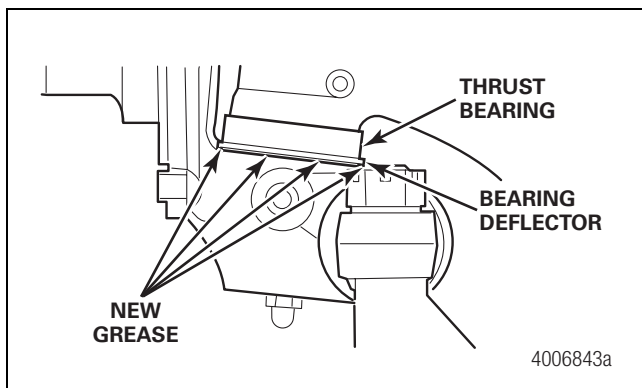

Figure 6.32

Axles with Unitized Wheel Ends

1. Park the vehicle on a level surface. Block the wheels to keep the vehicle from moving. Set the parking brake.
2. Verify that the tires touch the ground. DO NOT RAISE THE VEHICLE.
3. Clean off all grease fittings prior to lubrication.
4. Lubricate the king pins through the grease fittings on the top and bottom king pin caps. Figure 6.33.

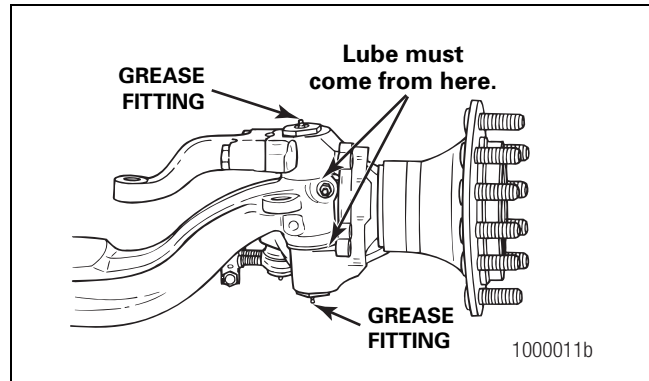

Figure 6.33

5. Force lubricant into the upper and lower king pin grease fitting caps until new lubricant flows from between the upper axle beam end and the knuckle, and the lower axle beam end and the knuckle. Figure 6.33.

Ball Studs on the Steering Arm and the Tie Rod Arm Ends

Axles with Conventional and Unitized Wheel Ends

1. Park the vehicle on a level surface. Block the wheels to prevent the vehicle from moving. Set the parking brake.
2. Verify that the tires touch the ground. DO NOT RAISE THE VEHICLE.
3. Clean off all grease fittings prior to lubrication.
4. Apply lubricant until new lubricant comes from the boot. Figure 6.34 and Figure 6.35.

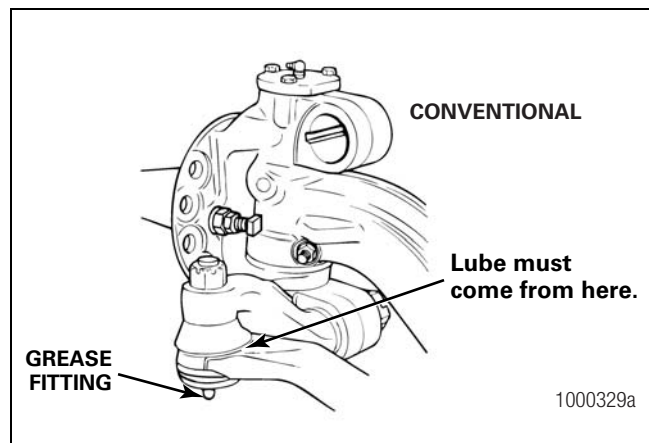

Figure 6.34

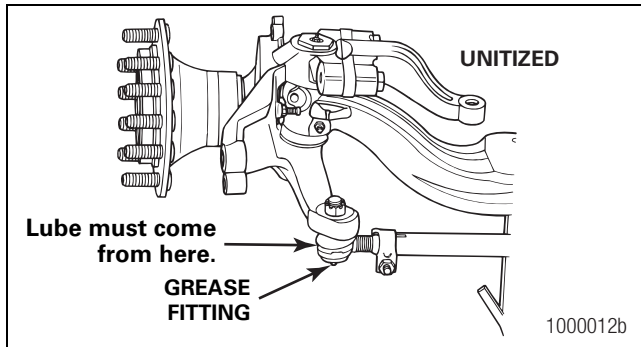

Figure 6.35

Grease-Lubricated Wheel Bearings

Axles with Conventional Wheel Ends

NOTE: This procedure applies to hubs with grease-lubricated wheel bearings.

1. Park the vehicle on a level surface. Block the wheels to keep the vehicle from moving. Set the parking brake.
2. Remove the tire and wheel assembly. Remove and disassemble the hub. Refer to Wheel Ends in Maintenance Manual 2, Front Non-Drive Steer Axles. To obtain this publication, refer to the Service Notes page on the front inside cover of this manual.
3. Remove the old lubricant from all parts. Discard the seals. Inspect the wheel bearings for wear or damage. Replace worn or damaged bearings. Refer to Maintenance Manual 2, Front Non-Drive Steer Axles. To obtain this publication, refer to the Service Notes page on the front inside cover of this manual.
4. Force the specified lubricant from the large end of the cones into the cavities between the rollers and cage. Pack the hub between the bearing cups with lubricant to the level of the smallest diameter of the cups. Figure 6.36.

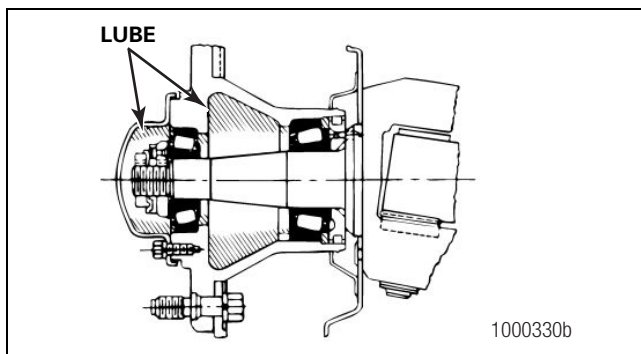

Figure 6.36

5. Install the inner and outer bearing cones into the cups in the hubs. The bearing cups must be pressed tight against the shoulder in the hubs.
6. Install new wheel seals into the hubs.
7. Install the hub and the wheel and tire assembly. Install the outer wheel bearing cone into the hub. Install the adjusting nut.
8. Adjust the wheel bearings.

Oil-Lubricated Wheel Bearings

Axles with Conventional Wheel Ends

NOTE: This procedure applies to hubs with oil-lubricated wheel bearings.

1. Check the level on the cap. If the oil level is not at the specified level on the cap, remove the fill plug.
2. Add the specified oil until the oil is at the specified level. Figure 6.37.

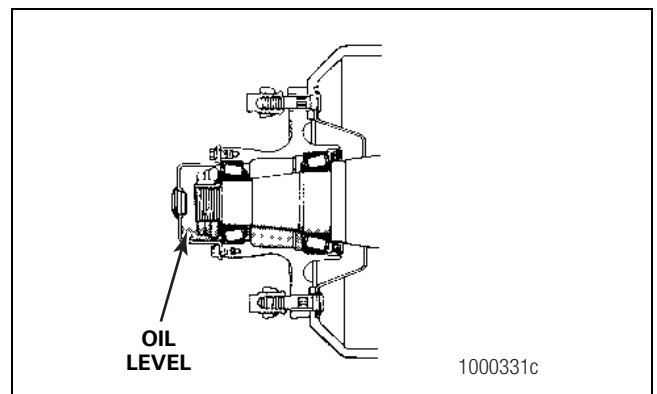

Figure 6.37

6 Front Non-Drive Steer Axles

Check and Adjust

Steering Arm Bolts

⚠ WARNING

Take care when you use Loctite® adhesive to avoid serious personal injury. Read the manufacturer's instructions before using this product. Follow the instructions carefully to prevent irritation to the eyes and skin. If Loctite® adhesive material gets into your eyes, follow the manufacturer's emergency procedures. Have your eyes checked by a physician as soon as possible.

1. Check the steering arm bolts for minimum torque. Refer to the table below.

| Axle | Torque lb-ft (N•m) |
|-----------------|--------------------|
| MFS-6 | 215-265 (290-360) |
| MFS-7 or MFS-8 | 360-470 (490-638) |
| All other axles | 300-450 (406-610) |

- If steering arm bolt torque has fallen below minimum torque:
 - A. Remove the bolts. Clean all the threads. Install new Loctite® 680 adhesive, Meritor part number 2297-K-5523.
 - B. Tighten the bolts to specification. Refer to the table above.
- 2. Check the steering arm bolt torque every 200,000 miles (320 000 km) or 24 months.
- 3. Refer to Maintenance Manual 2, Front Non-Drive Steer Axles, for Dri-Loc® fastener installation procedures. To obtain this publication, refer to the Service Notes page on the front inside cover of this manual.

Tighten Draw Key Nuts

Axles with Conventional and Unitized Wheel Ends

NOTE: This procedure applies to all except 901, 903 and 970 Series axles. These axles do not use a draw key. Refer to the identification tag on the front of the axle beam.

Tighten the nuts on the side of the knuckle that hold the draw keys to 30-45 lb-ft (41-61 N•m) at the following times. Figure 6.38 and Figure 6.39. **🔧**

- After the first 6,000 miles (10 000 km) of new vehicle operation
- Every 36,000 miles (58 000 km) of operation

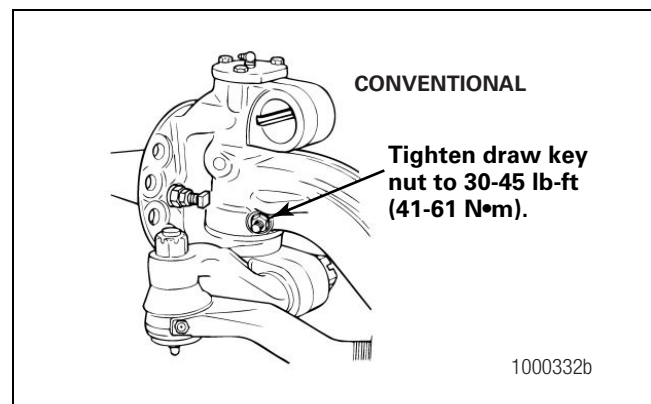

Figure 6.38

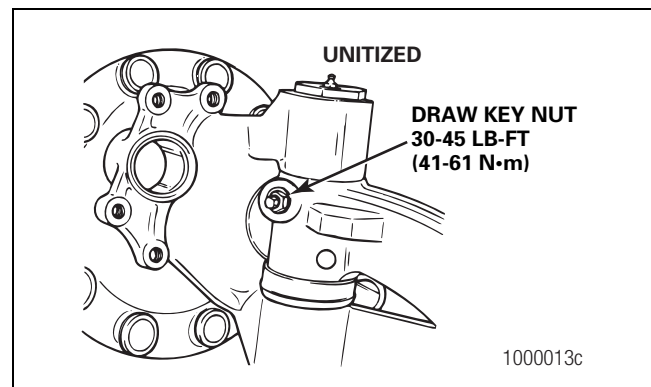

Figure 6.39

Lubrication Intervals and Specifications

Refer to the tables in this section for lubrication, inspection and maintenance schedules based on vehicle usage.

Table AT: Vocational Groups

| Group Number | Typical Vocations | Vehicle Build | Typical Operation Conditions |
|--------------|---|---|---|
| 1 | On-highway or turnpike, linehaul only | After July 1, 1996 Before July 1, 1996, use category 3 | High mileage operation, more than 50,000 miles/year (80 500 km/year) 95% on-highway/turnpike surface |
| 2 | Fire and rescue, city delivery, inner city coach, heavy haul, school bus, motor home, transit coach | After July 1, 1996 Before July 1, 1996, use category 3 | Lower mileage operation, less than 50,000 miles/year (80 500 km/year) |
| 3 | Logging, oil field, construction, heavy haul, yard tractor (highway licensed), residential refuse | ALL | Low mileage operation, less than 25,000 miles/year (40 250 km/year) Heavy-duty service with substantial off-road operation |
| 4 | Mining, yard tractor (non-highway licensed), and land fill refuse | | Heavy-duty service |
| 5 | Mining, logging and construction | | Severe duty 80-100% off highway |

6 Front Non-Drive Steer Axles

Table AU: Lubrication, Inspection and Maintenance Schedule

| Component | Service Intervals | | | | | | | | | |
|--|-------------------|---------------------------------|--|--------------------------|--------------------------|--------------------------|--------------------------|--------------------------|----------------------------|----------------------------|
| | 48 hours | 5,000 miles (8050 km)/100 hours | First 6,000 miles (10 000 km) of operation | 10,000 miles (16 100 km) | 20,000 miles (32 200 km) | 36,000 miles (58 000 km) | 40,000 miles (64 000 km) | 50,000 miles (80 500 km) | 100,000 miles (160 000 km) | 200,000 miles (320 000 km) |
| Tie Rod Ends | | | | | | | | | | |
| Group 1 Vocations | | | | | | | | | L* | |
| Group 2 Vocations | | | | | | | L* | | | |
| Group 3 Vocations | | | | , L* | | | | | | |
| Group 4 Vocations | | , L* | | | | | | | | |
| Group 5 Vocations | , L* | | | | | | | | | |
| Inspect the Tie Rod Assembly for Movement | | | | | | | | | | |
| Group 1 Vocations | | | | | | | | | | |
| Group 2 Vocations | | | | | | | | | | |
| Group 3 Vocations | | | | | | | | | | |
| Group 4 Vocations | | | | | | | | | | |
| Group 5 Vocations | | | | | | | | | | |
| Tie Rod End Shop Inspection | | | | | | | | | | |
| Ball Studs on Steering Arms | | | | | | | | | L* | |
| Easy Steer Plus Axle Ball Studs | | | | | | | | | | |
| Sealed Axle Ball Studs | | | | | | | | | | |
| King Pins and Bushings | | | | | | | | | L* | |
| Steering Arms Bolts | | | | | | | | | | |
| Thrust Bearings | | | | | | | | | L* | |

Table AU: Lubrication, Inspection and Maintenance Schedule

| Component | Service Intervals | | | | | | | | | |
|--|-------------------|---------------------------------|--|--------------------------|--------------------------|--------------------------|--------------------------|--------------------------|----------------------------|----------------------------|
| | 48 hours | 5,000 miles (8050 km)/100 hours | First 6,000 miles (10 000 km) of operation | 10,000 miles (16 100 km) | 20,000 miles (32 200 km) | 36,000 miles (58 000 km) | 40,000 miles (64 000 km) | 50,000 miles (80 500 km) | 100,000 miles (160 000 km) | 200,000 miles (320 000 km) |
| Steering Knuckle Vertical End Play Inspection | | | | | | | | | | |
| Group 1 Vocations | | | | | | | | | | |
| Group 2 Vocations | | | | | | | | | | |
| Group 3 Vocations | | | | | | | | | | |
| Group 4 Vocations | | | | | | | | | | |
| Group 5 Vocations | | | | | | | | | | |
| Upper and Lower King Pin Bushings for Wear | | | | | | | | | | |
| Group 1 Vocations | | | | | | | | | | |
| Group 2 Vocations | | | | | | | | | | |
| Group 3 Vocations | | | | | | | | | | |
| Group 4 Vocations | | | | | | | | | | |
| Group 5 Vocations | | | | | | | | | | |
| Draw Key Nuts | | | T | | | T | | | | |
| Sealed Hub Unit Inspection | | | | | | | | | | |

I = Inspect

L = Lubricate

T = Tighten to specified torque

* If power washers are used during vehicle cleaning operations, lubrication intervals need to be adjusted. Frequent power-washed vehicles will require more frequent lubrication.

6 Front Non-Drive Steer Axles

Lubricant

Table AV: Front Non-Drive Axle Greasing Specifications

| Grease* | Meritor Specification | NLGI Grade | Grease Classification | Outside Temperature |
|-----------------------|------------------------------|-------------------|---------------------------------|---|
| Multi-Purpose Grease* | 0-617-A | 1 | 6% Lithium 12-Hydroxyl Stearate | Refer to the grease manufacturer's specifications for the temperature service limits. |
| | 0-617-B | 2 | 8% Lithium 12-Hydroxyl Stearate | |

* Meritor recognizes that industry trends are moving toward increased selection and usage of synthetic grease in vehicle maintenance. However, some seals are known to expand when in contact with synthetic grease. Consult your local Meritor representative for synthetic grease application references BEFORE using any synthetic grease when performing axle service and maintenance.

Troubleshooting

Table AW: Front Non-Drive Steer Axle Diagnostic Table

| Condition | Cause | Correction |
|---|---|--|
| Tires wear out quickly or have uneven tire tread wear. | Tires have incorrect air pressure | Place the specified air pressure in the tires. |
| | Tires out-of-balance | Balance or replace the tires. |
| | Incorrect tandem axle alignment | Align the tandem axles. |
| | Incorrect toe-in setting | Adjust the toe-in specified setting. |
| | Incorrect steering arm geometry | Service the steering system as necessary. |
| | Excessive wheel-end play exists | Readjust the wheel bearings. |
| Vehicle is hard to steer. | Power steering system pressure low | Repair the power steering system. |
| | Steering gear linkage not assembled correctly | Assemble the steering gear correctly. |
| | Steering linkage needs lubrication | Lubricate the steering linkage. |
| | King pins binding | Replace the king pins. |
| | Incorrect steering arm geometry | Service the steering system as necessary. |
| | Caster out-of-adjustment | Adjust the caster as necessary. |
| | Tie rod ends hard to move | Replace the tie rod ends. |
| | Worn thrust bearing | Replace the thrust bearing. |
| Tie rod ends are worn and require replacement. | Tie rod ends require lubrication | Lubricate the cross tube ends. Verify that the lubrication schedule is followed. |
| | Severe operating conditions | Increase the frequency of inspection and lubrication intervals. |
| | Damaged boot on tie rod end | Replace the boot. |

Table AW: Front Non-Drive Steer Axle Diagnostic Table

| Condition | Cause | Correction |
|---|--|---|
| Bent or broken cross tube, tie rod end ball stud, steering arm or tie rod end. Component requires replacement. | Too much pressure in the power steering system, pressure exceeds OEM specification | Adjust the power steering system to the specified pressure. |
| | Power steering system cut-off pressure, out-of-adjustment | Adjust the power steering system to the specified pressure. |
| | Vehicle operated under severe conditions | Verify that the vehicle is operated correctly. |
| | Add-on type of power steering system not installed correctly | Correctly install the add-on power steering system. |
| | Steering gear overtravel poppets incorrectly set or malfunctioning | Check for correct operation or adjust the overtravel of the poppets to the manufacturer's specifications. |
| Worn or broken steering ball stud | Axle stops incorrectly set | Set the axle stops to the manufacturer's specification. |
| | Drag link fasteners tightened higher than vehicle manufacturer's specifications | Tighten the drag link fasteners to the vehicle manufacturer's specified torque. |
| | Lack of lubrication or incorrect lubricant | Lubricate the linkage with the specified lubricant. |
| Worn king pins and king pin bushings | Power steering stops out-of-adjustment | Adjust the stops to the specified dimension. |
| | Worn or missing seals and gaskets | Replace the seals and gaskets. |
| | Incorrect lubricant | Lubricate the axle with the specified lubricant. |
| | Axle not lubricated at scheduled frequency | Lubricate the axle at the scheduled intervals. |
| | Incorrect lubrication procedures | Use the correct lubrication procedures. |
| Vibration or shimmy of front axle during operation | Lubrication schedule does not match operating conditions | Change the lubrication schedule to match the operating conditions. |
| | Caster out-of-adjustment | Adjust the caster. |
| | Wheels or tires out-of-balance | Balance or replace the wheels or tires. |
| | Worn shock absorbers | Replace the shock absorbers. |

7 Brakes

Hazard Alert Messages

Read and observe all Warning and Caution hazard alert messages in this publication. They provide information that can help prevent serious personal injury, damage to components, or both.

⚠ WARNING

To prevent serious eye injury, always wear safe eye protection when you perform vehicle maintenance or service.

⚠ ASBESTOS AND NON-ASBESTOS FIBERS WARNING

Some brake linings contain asbestos fibers, a cancer and lung disease hazard. Some brake linings contain non-asbestos fibers, whose long-term effects to health are unknown. You must use caution when you handle both asbestos and non-asbestos materials.

Cam Brakes

Technical Publications

How to Obtain Additional Maintenance and Service Information

Refer to the publications in Table AX. To obtain these publications, refer to the Service Notes page on the front inside cover of this manual.

Table AX: Publications

| Model | Manual |
|--|---------------------------------|
| Cam Brakes and Automatic Slack Adjusters | Maintenance Manual 4 |
| Q Plus™ LX500 and MX500 Cam Brakes | Maintenance Manual MM-96173 |
| Cam Brakes | Failure Analysis Manual TP-0445 |

Description

Q Plus™ and Cast Plus™; and Q, P and T Series

Meritor cam brakes are air-actuated, cam-operated, two-shoe brakes with each shoe mounted on a separate anchor pin. The brakes are available with automatic slack adjusters and can be assembled with air chambers. Q, Q Plus™ and P Series brakes are available with brake lining wear sensors. Figure 7.1, Figure 7.2, Figure 7.3 and Figure 7.4.

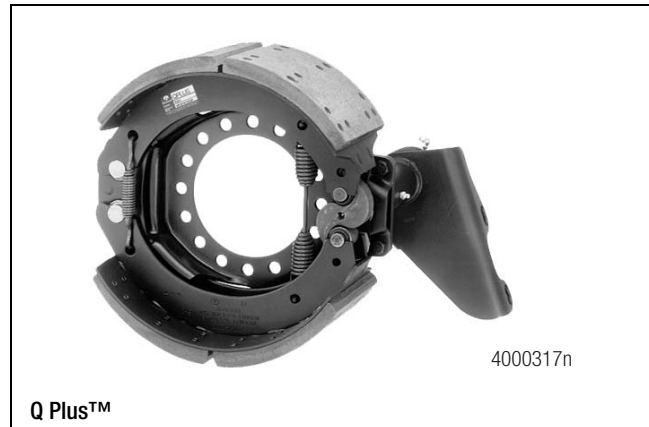

Q Plus™

Figure 7.1

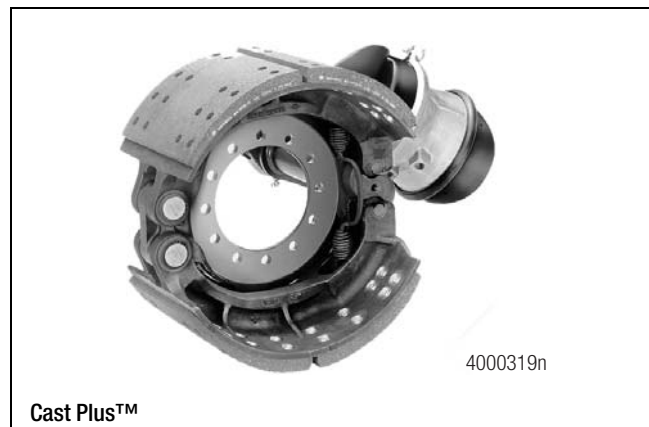

Cast Plus™

Figure 7.2



P Series

Figure 7.3



T Series

Figure 7.4

Q Plus™ LX Cam Brake Package with the Extended Lube Feature

This package is available for on-highway linehaul, city delivery and school bus applications, and includes the following features.

- For linehaul applications, camshafts and automatic slack adjusters do not require lubrication for three years or 500,000 miles (800 000 km), whichever comes first.
- For city delivery and school bus applications, camshafts and automatic slack adjusters do not require lubrication for one year or unlimited miles, whichever comes first.
- Meritor factory-installed automatic slack adjusters

Q Plus™ MX Cam Brake Extended Maintenance Package Option

This package is available for on-highway linehaul applications only and includes the following features.

- Proprietary friction material on five-inch wide shoes for front axles, and eight-inch wide shoes for rear axles for more wearable volume do not require reline for three years or 500,000 miles (800 000 km), whichever comes first.
- Camshafts and automatic slack adjusters do not require lubrication for three years or 500,000 miles (800 000 km), whichever comes first.
- Meritor factory-installed automatic slack adjusters

Identification

Cam brakes are identified as follows.

- A model number tag for the brake assembly is located on the camshaft tube.
- An example of a part number format for a 16.5 Q Plus™ brake is QP1 1657 1234.

In addition to the model number tag on the cam tube, a brake shoe label is attached to the brake shoe web. This label provides information on brake type, lining material and service parts replacement number. Figure 7.5.

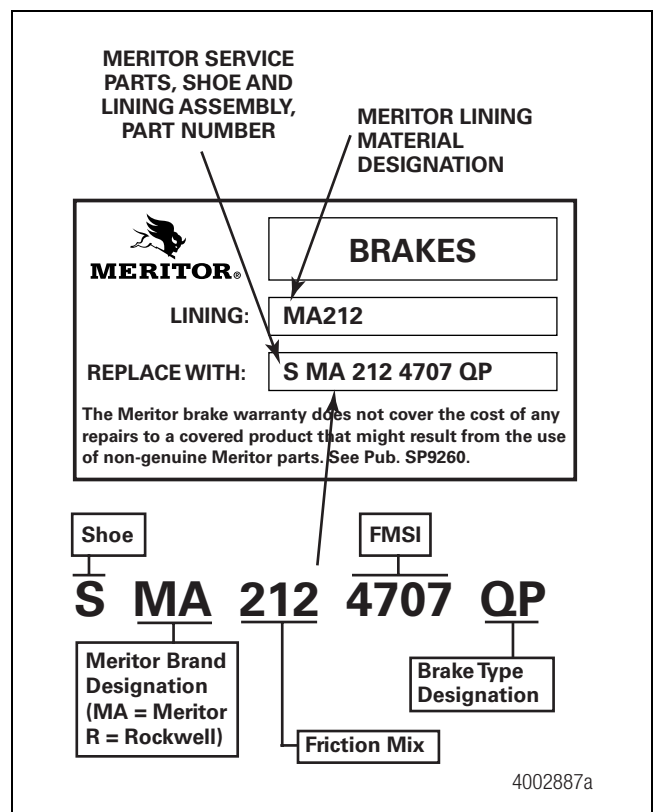

Figure 7.5

7 Brakes

The brake shoe lining also contains identification. Figure 7.6. The information that exists on the edge code of the lining is listed in the following order.

- Meritor stamped logo
- Lining mix designation
- Friction code
- Friction Material Standards Institute (FMSI) number, four to eight spaces
- Block type
- Meritor part number, last four digits
- Word drawing engineering change letter
- Julian date, four or five characters

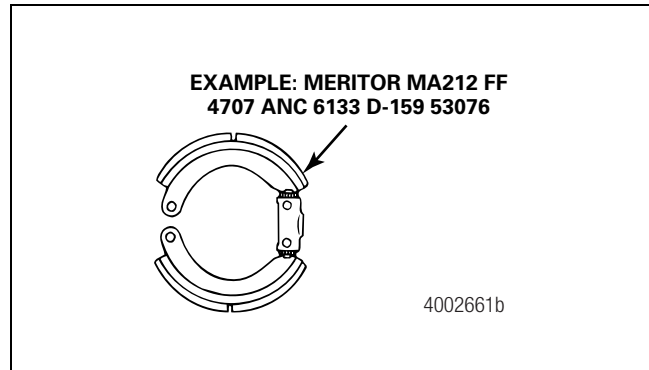

Figure 7.6

Model Nomenclature

Refer to Figure 7.7 for an explanation of brake model numbers.

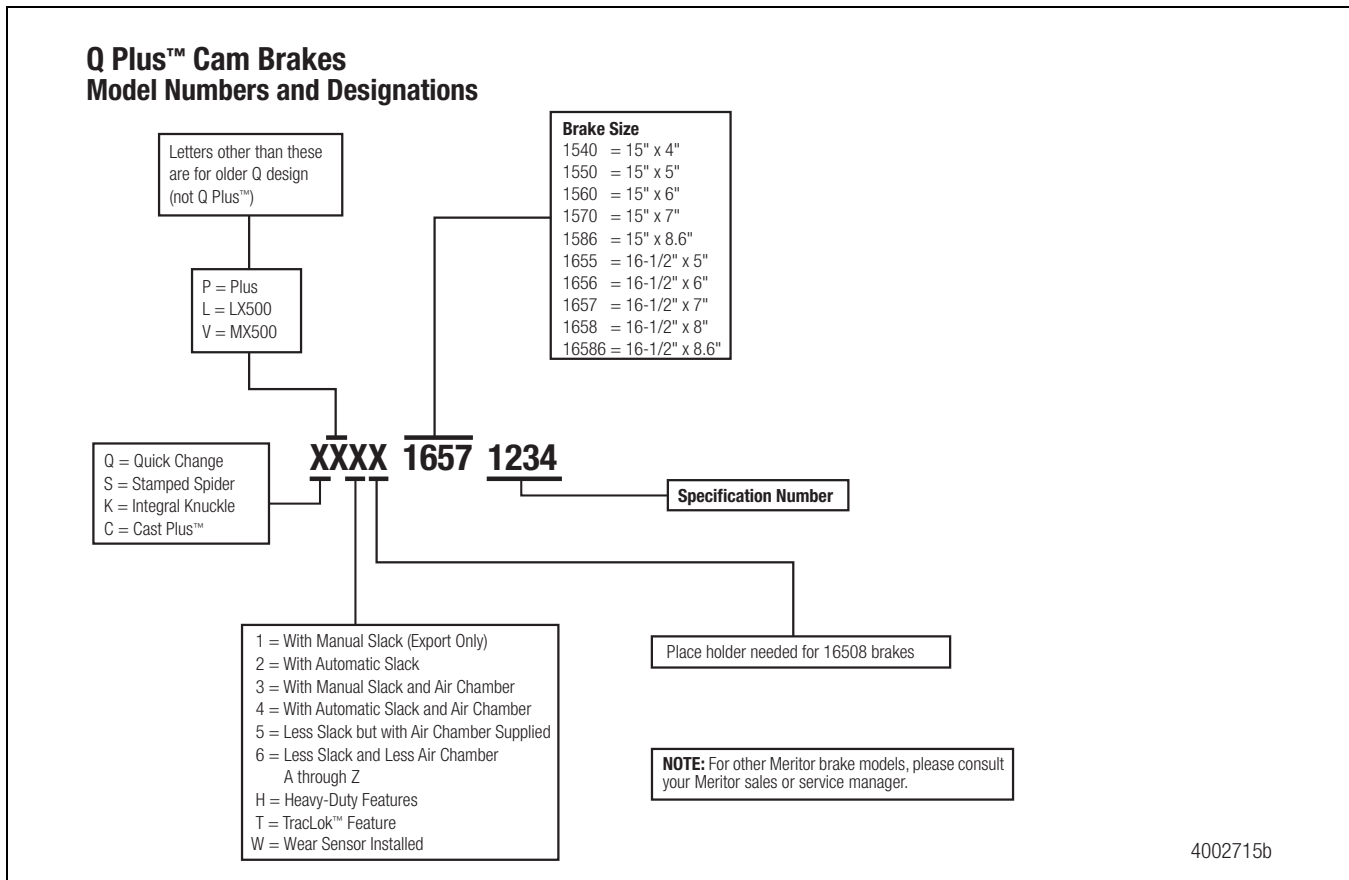

Figure 7.7

Important Information

Meritor automatic slack adjusters (ASAs) should not need to be manually adjusted in service. ASAs should not have to be adjusted to correct excessive pushrod stroke. The excessive stroke may be an indication that a problem exists with the foundation brake, ASA, brake actuator or other system components.

Meritor recommends troubleshooting the problem, replacing suspect components and then confirming proper brake operation prior to returning the vehicle into service.

In the event that a manual adjustment must be made (although not a common practice), a service appointment and full foundation brake, ASA, and other system component inspection should be conducted as soon as possible to ensure integrity of the overall brake system.

For Meritor brake adjustment, refer to the brake adjustment tables in this section. For non-Meritor brake adjusters, refer to the brake manufacturer's service procedures.

Cam Brake Inspection Intervals and Procedures

On-Highway Linehaul Applications

Q Plus™, Cast Plus™ and Q Series Brakes

Every 100,000 miles (160 000 km) or every six months, whichever comes first.

P Series Brakes

Every 50,000 miles (80 000 km) or every six months, whichever comes first.

Off-Highway Linehaul Applications

At least every four months, when you replace the seals, and reline the brakes.

Every two weeks during the first four-month period, inspect for hardened or contaminated grease and for the absence of grease to help determine lubrication intervals.

Lubricate more often for severe-duty applications.

Q Plus™ LX500 and MX500 Cam Brakes with Automatic Slack Adjusters

The Q Plus™ LX500 and MX500 cam brake packages include factory-installed Meritor automatic slack adjusters. Q Plus™ LX500 and MX500 cam brakes and slack adjusters do not require lubrication for an extended period of time. Refer to the table below.

The camshaft hardware, seals, bushings and washers, do not require replacement for the same time period.

However, you must continue to observe all other brake preventive maintenance schedules and procedures for both Q Plus™ LX500 and MX500 cam brakes and Meritor automatic slack adjusters.

Do Not Lubricate the LX500 and MX500 Brakes and Automatic Slack Adjuster Before the Specified Time or Mileage Intervals

The Q Plus™ LX500 and MX500 cam brake packages include factory-installed Meritor automatic slack adjusters. Q Plus™ LX500 and MX500 cam brakes and slack adjusters do not require lubrication for an extended period of time.

- Do not remove the identification tag that covers the grease plug.
- Do not grease the brake assembly or the automatic slack adjuster prior to the specified lubrication interval times or mileage in the table.

Inspection Procedure

1. Check the complete air system for worn hoses and connectors. With the air pressure at 100 psi (689 kPa), the brakes released and the engine off, loss of tractor air pressure must not exceed two psi (14 kPa) a minute. Total tractor and trailer loss must not exceed three psi (21 kPa) per minute.
2. Check to see that the air compressor drive belt is tight. Air system pressure must rise to approximately 100 psi (689 kPa) in two minutes.
3. The governor must be checked and set to the specifications supplied by the vehicle manufacturer.
4. Both the tractor and trailer air systems must match the specifications supplied by the vehicle manufacturer.
5. Both wheel ends of each axle must have the same linings and drums. All four wheel ends of the tandem axles also must have the same linings and drums. It is not necessary for the front axle brakes to be the same as the rear driving axle brakes. Figure 7.8.

7 Brakes

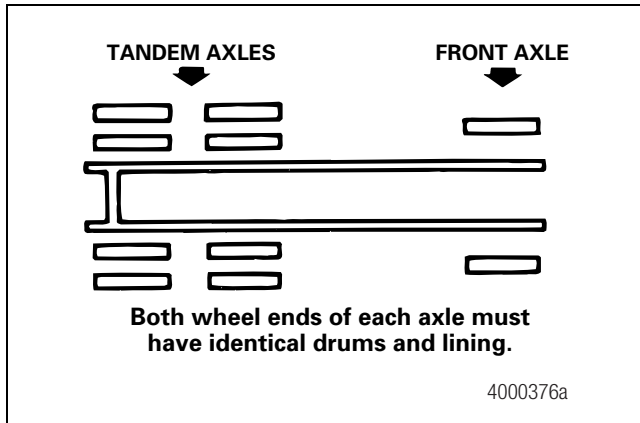

Figure 7.8

6. Always follow the specifications supplied by the vehicle manufacturer for the correct lining to be used. Vehicle brake systems must have the correct friction material and these requirements can change from vehicle to vehicle.
7. The return springs must retract the shoes completely when the brakes are released. Replace the return springs each time the brakes are relined. The spring brakes must retract completely when they are released.
8. The air chamber area multiplied by the length of the automatic slack adjuster is called the AL factor. This number must be equal for both ends of a single axle and all four ends of a tandem axle. Figure 7.9.

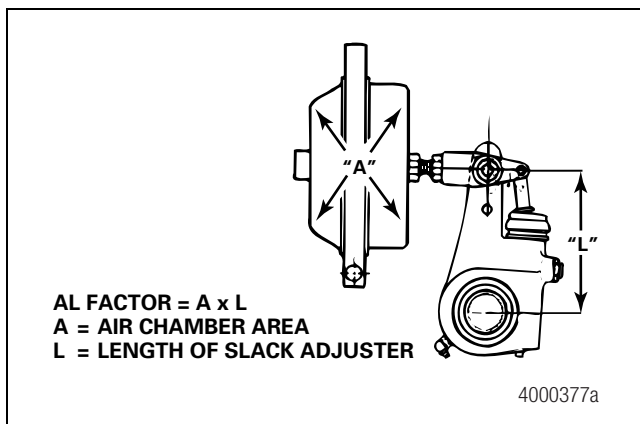

Figure 7.9

9. Measure the brake free stroke and adjust the chamber stroke.
10. Lubricate the brake system components.

Cam Brakes, All Models

⚠ WARNING

Before you service a spring chamber, carefully follow the manufacturer's instructions to compress and lock the spring to completely release the brake. Verify that no air pressure remains in the service chamber before you proceed. Sudden release of compressed air can cause serious personal injury and damage to components.

When you perform preventive maintenance procedures on an in-service brake, check both the free stroke and adjusted chamber stroke.

Free stroke sets the clearance between the linings and drum. The in-service free stroke may be slightly longer than 0.5-0.625-inch (12.7-15.9 mm) specified in this procedure. This is not a concern if the adjusted chamber stroke is within the limits shown in Table AY and Table AZ.

Measure Free Stroke

Before taking measurements, verify that the brakes are fully released. Cage the spring brake chambers if equipped.

1. Measure the distance from the center of the large clevis pin to the bottom of the air chamber while the brake is released. The measurement you obtain is X in Figure 7.10.

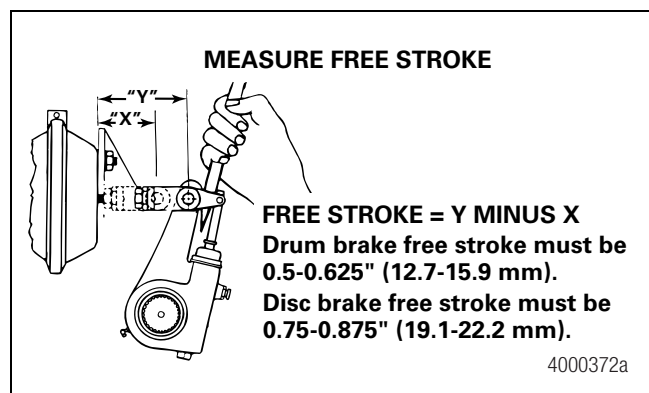

Figure 7.10

2. Use a pry bar to move the slack adjuster and position the linings against the drum with brakes applied. Measure the same distance again while the brakes are applied. The measurement you obtain is Y in Figure 7.10.

CAUTION

Do not set the free stroke shorter than 0.5-0.625-inch (12.7-15.9 mm) for drum brakes. If the measurement is too short, linings can drag. Damage to components can result.

3. Subtract X from Y to obtain the in-service free stroke. The measurement must be 0.5-0.625-inch (12.7-15.9 mm) for drum brakes. Figure 7.10.
 - **If the free stroke measurement is not within specification:** Refer to Diagnostic Charts, Table B0, in this section.

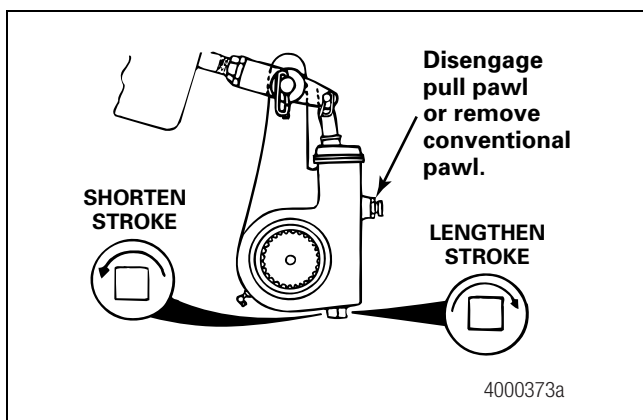

Figure 7.11

4. If the brakes have spring chambers, carefully release the springs. Test the vehicle before you return it to service.

Important Information

Meritor automatic slack adjusters (ASAs) should not need to be manually adjusted in service. ASAs should not have to be adjusted to correct excessive pushrod stroke. The excessive stroke may be an indication that a problem exists with the foundation brake, ASA, brake actuator or other system components.

Meritor recommends troubleshooting the problem, replacing suspect components and then confirming proper brake operation prior to returning the vehicle into service.

In the event that a manual adjustment must be made (although not a common practice), a service appointment and full foundation brake, ASA, and other system component inspection should be conducted as soon as possible to ensure integrity of the overall brake system.

For Meritor brake adjustment, refer to the brake adjustment tables in this section. For non-Meritor brake adjusters, refer to the brake manufacturer's service procedures.

Commercial Vehicle Safety Alliance (CVSA) Guidelines

Measure Push Rod Travel or Adjusted Chamber Stroke

Use the following procedure to check in-service push rod travel or adjusted chamber stroke on truck and tractor brakes.

WARNING

Before you service a spring chamber, carefully follow the manufacturer's instructions to compress and lock the spring to completely release the brake. Verify that no air pressure remains in the service chamber before you proceed. Sudden release of compressed air can cause serious personal injury and damage to components.

1. The engine must be OFF. If the brake has a spring chamber, follow the manufacturer's instructions to release the spring. Verify that no air pressure remains in the service section of the chamber.
2. Verify that pressure is 100 psi (689 kPa) in the air tanks. Determine the size and type of brake chambers on the vehicle.
3. With the brakes released, mark the push rod where it exits the chamber. Measure and record the distance. Have another person apply and hold the brakes on full application. Figure 7.12. Hold the ruler parallel to the push rod and measure as carefully as possible. A measurement error can affect CVSA re-adjustment limits. CVSA states that "any brake 1/4-inch or more past the re-adjustment limit, or any two brakes less than 1/4-inch beyond the re-adjustment limit, will be cause for rejection."

7 Brakes

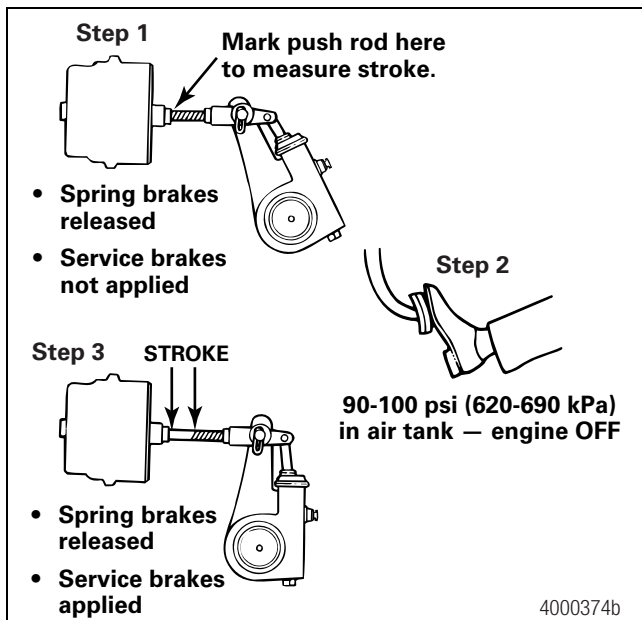

Figure 7.12

4. Measure the push rod travel or adjusted chamber stroke from where the push rod exits the brake chamber to your mark on the push rod. Measure and record the distance. Figure 7.12.
5. Subtract the measurement you recorded in Step 3 from the measurement you recorded in Step 4. The difference is the push rod travel or adjusted chamber stroke.
6. Refer to Table AY or Table AZ to verify that the stroke length is correct for the size and type of air chambers on the vehicle.
 - If the push rod travel or adjusted chamber stroke is greater than the maximum stroke shown in Table AY or Table AZ: Refer to Diagnostic Charts, Table BO, in this section.

Table AY: Standard-Stroke Clamp-Type Brake Chamber Data

| Type | Outside Diameter (inches) | Brake Adjustment Limit (inches) |
|------|---------------------------|---------------------------------|
| 6 | 4-1/2 | 1-1/4 |
| 9 | 5-1/4 | 1-3/8 |
| 12 | 5-4/16 | 1-3/8 |
| 16 | 6-3/8 | 1-3/4 |
| 20 | 6-25/32 | 1-3/4 |
| 24 | 7-7/32 | 1-3/4 |
| 30 | 8-3/32 | 2 |
| 36 | 9 | 2-1/4 |

Table AZ: Long-Stroke Clamp-Type Brake Chamber Data*

| Type | Outside Diameter (inches) | Brake Adjustment Limit (inches) |
|------|---------------------------|---------------------------------|
| 16 | 6-3/8 | 2.0 |
| 20 | 6-25/32 | 2.0 |
| 24 | 7-7/32 | 2.0 |
| 24 | 7-7/32 | 2.5 |
| 30 | 8-3/32 | 2.5 |

*For 3" maximum stroke type 24 chambers.

Alternate Method to Measure Push Rod Travel (Adjusted Chamber Stroke)

Use the CVSA procedure, except in Steps 3-4, measure the distance from the bottom of the air chamber to the center of the large clevis pin on each of the brakes.

CVSA North American Out-of-Service Criteria Reference Tables

Information contained in Table AY and Table AZ is for reference only. Consult the CVSA's Out-of-Service Criteria Handbook for North American Standards, Appendix A. Visit their website at <http://64.35.82.7/> to obtain the handbook.

Cam Brake Lubrication Intervals and Procedures

Before you perform lubrication procedures, release the brakes to ensure the camshaft bushings and automatic slack adjusters will be sufficiently lubricated. If the brake has a spring brake, compress and lock the spring to completely release the brake. No air pressure must remain in the service half of the air chamber.

Brake Inspections Before the Recommended Lubrication Interval

NOTE: You do not have to replace Q Plus™ LX500 and MX500 brake camshaft bushings and seals when you reline the brake prior to the recommended service interval.

1. Periodically inspect brake shoe linings. If the lining thickness is 0.25-inch (6.35 mm) at the thinnest point, reline the brakes. Refer to Maintenance Manual MM-96173, Q Plus™ LX500 and MX500 Cam Brakes, for more information. To obtain this publication, refer to the Service Notes page on the front inside cover of this manual.

- Periodically inspect the brakes for correct clearance between the lining and drum. If you must manually adjust the brakes because of excessive air chamber stroke, correct the problem. Refer to Maintenance Manual MM-96173, Q Plus™ LX500 and MX500 Cam Brakes, for more information. To obtain this publication, refer to the Service Notes page on the front inside cover of this manual.

Table BA: Q Plus™ LX500 and MX500 Cam Brake Lubrication Intervals

| Q Plus™ LX500 Cam Brake | |
|-------------------------|------------------------------------|
| On-Highway Linehaul | 3 years/500,000 miles (805 000 km) |
| All Other Applications | 1 year, regardless of mileage |
| Q Plus™ LX500 Cam Brake | |
| On-Highway Linehaul | 3 years/500,000 miles (805 000 km) |

Camshaft Bushings

Lubricate through the fitting on the bracket or spider until new grease flows from the inboard seal.

Rollers and Anchor Pins

When the brake is disassembled, or when necessary, lubricate the anchor pins and rollers where these parts touch the brake shoes.

Do not allow the grease to contact the area of the camshaft roller that touches the camshaft head. Figure 7.13 and Figure 7.14.

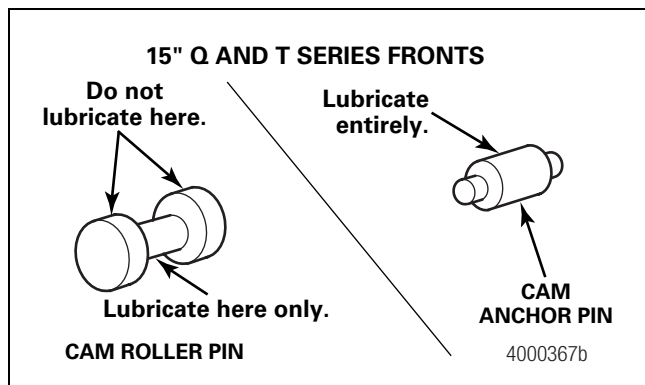

Figure 7.13

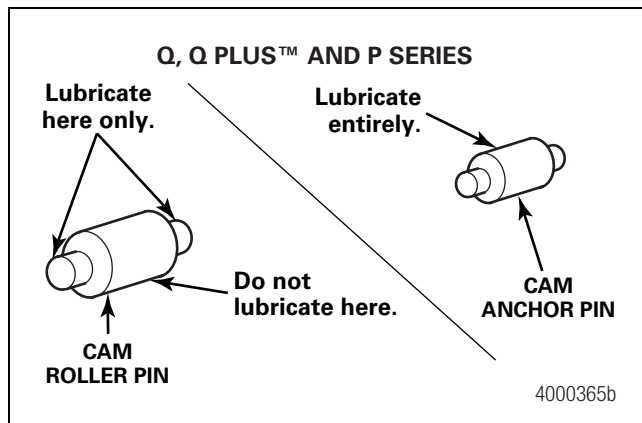

Figure 7.14

Automatic Slack Adjuster

Before you perform lubrication procedures, release the brakes to ensure the camshaft bushings and automatic slack adjusters will be sufficiently lubricated. If the brake has a spring brake, compress and lock the spring to completely release the brake. No air pressure must remain in the service half of the air chamber.

Inspect and lubricate the automatic slack adjuster according to one of the schedules below. Use the schedule that requires the most frequent inspection and lubrication, and whenever you relined the brakes. Refer to Table BM for grease specifications.

- Vehicle manufacturer's schedule
- Fleet's schedule
- Every six months
- A minimum of four times during the life of the linings

Anti-Seize Compound

Meritor lubricant specification O-637, part number 2297-U-4571, is a corrosion-control grease. Do not mix this grease with other greases. This compound is also available from the Southwest Petro-Chemical Division of Witco Chemical Corporation, 1400 South Harrison, Olathe, KS 66061, as Corrosion Control, part number SA 8249496.

- Use anti-seize compound on the clevis pins of all slack adjusters.
- Also use anti-seize compound on the automatic slack adjuster and cam splines if the slack adjuster gear has no grease groove and holes around its inner diameter.

7 Brakes

Q Plus™ LX500 and MX500 Cam Brakes and Automatic Slack Adjusters After the Specified Time or Mileage Intervals

Brakes Without a Pressure Relief Valve Built Prior to July 2000

WARNING

To prevent serious eye injury, always wear safe eye protection when you perform vehicle maintenance or service.

Park the vehicle on a level surface. Block the wheels to prevent the vehicle from moving. Support the vehicle with safety stands. Do not work under a vehicle supported only with jacks. Jacks can slip and fall over. Serious personal injury and damage to components can result.

1. Park the vehicle on a level surface. Block the wheels to prevent the vehicle from moving. Release the brakes to ensure the camshaft bushings and automatic slack adjusters will be sufficiently lubricated.
2. Remove the identification tag from the chamber bracket.
3. Remove the grease plugs from both the chamber bracket and the automatic slack adjuster.
4. Remove the automatic slack adjuster. Remove the O-ring from the splined gear. Discard the O-ring. Install the automatic slack adjuster onto the camshaft.
5. Install new grease fittings. Use Meritor-approved O-701 calcium-base NLGI Grade 2 synthetic grease to lubricate the brake assembly through the grease fitting in the bracket until new grease flows from the inboard, slack end, seal.
6. Use Meritor-approved O-701 calcium-base NLGI Grade 2 synthetic grease to lubricate the automatic slack adjuster through the grease fitting until new grease purges from the pull pawl, or the boot begins to expand.
7. After the first lubrication, follow the manufacturer's chassis lubrication schedule and your regular preventive maintenance schedule. You should also continue to perform periodic inspections of the brakes.

Brakes with a Pressure Relief Valve Built After July 2000

WARNING

To prevent serious eye injury, always wear safe eye protection when you perform vehicle maintenance or service.

Park the vehicle on a level surface. Block the wheels to prevent the vehicle from moving. Support the vehicle with safety stands. Do not work under a vehicle supported only with jacks. Jacks can slip and fall over. Serious personal injury and damage to components can result.

1. Park the vehicle on a level surface. Block the wheels to prevent the vehicle from moving. Release the brakes to ensure the camshaft bushings and automatic slack adjusters will be sufficiently lubricated.
2. Remove the identification tag from the chamber bracket.
3. Remove the grease plugs from both the chamber bracket and the automatic slack adjuster.
4. Remove the automatic slack adjuster. Remove the O-ring from the splined gear. Discard the O-ring. Install the automatic slack adjuster onto the camshaft.
5. Install new grease fittings. Use Meritor-approved O-701 calcium-base NLGI Grade 2 synthetic grease to lubricate the brake assembly through the grease fitting in the bracket until new grease flows from the pressure relief valve in the bracket.
6. Use Meritor-approved O-701 calcium-base NLGI Grade 2 synthetic grease to lubricate the automatic slack adjuster through the grease fitting until new grease purges from the pull pawl, or the boot begins to expand.
7. After the first lubrication, follow the manufacturer's chassis lubrication schedule and your regular preventive maintenance schedule. You should also continue to perform periodic inspections of the brakes.

Cam Brake Tips

Air Chambers

To ensure correct brake balance, all brake chambers on the same axle must be the same size and type to help ensure a balanced brake system for maximum lining wear and drum life.

Brake Kits

Meritor brake shoes, rollers, camshafts and shoe return springs are designed to perform as a system. Always install original equipment manufacturer's components during maintenance or when you upgrade from standard to long-life brakes to help ensure correct brake performance and maximum lining life.

Cam Heads

Cam heads can look the same, but that doesn't mean they will perform the same in your brake system. Two cam head profiles can appear to be identical, but very small differences in the cams from different manufacturers can be significant enough to affect the performance of your brakes. To ensure a balanced brake system and optimum lining and drum life, always install the correct replacement cam.

Cam Rollers

To avoid flat spots, lubricate a cam roller directly in the web roller pocket and not at the cam-to-roller contact area. Flat spots can affect brake adjustment and result in premature brake wear or reduced braking performance.

Drums

To help ensure balanced braking, even lining and drum wear, and correct function of the automatic slack adjuster, do not install a cast drum and a centrifuse drum on the same axle.

A cast drum and a centrifuse drum each absorbs and dissipates heat differently. When drum types and weights are mixed, different rates of heat absorption and dissipation occur that can affect the brake system.

Hardware

When you service cam brakes, replace all the springs, anchor pins, bushings and rollers — not just the shoe return springs — to help ensure maximum braking performance.

Linings

Insist on the same brand of quality friction lining material recommended by the component equipment manufacturer to help ensure fewer relines and compatibility with your present system.

Approved Lubricants

Table BB: Cam Brake Grease Specifications

| Components | Meritor Specification | NLGI Grade | Grease Type | Outside Temperature |
|------------------------|-----------------------|----------------|-----------------------------|---|
| Retainer Clips | 0-616-A | 1 | Clay-Base | Down to -40°F (-40°C) |
| Anchor Pins | 0-617-A | 1 | Lithium 12-Hydroxy | Refer to the grease manufacturer's specifications for the temperature service limits. |
| Rollers, Journals Only | 0-617-B | 2 | Stearate or Lithium Complex | |
| Camshaft Bushings | 0-645 | 2 | Synthetic Oil, Clay-Base | Down to -65°F (-54°C) |
| | 0-692 | 1 and 2 | Lithium-Base | Down to -40°F (-40°C) |
| | Any of Above | Refer to Above | Refer to Above | Refer to Above |
| Camshaft Splines | 0-637* | 1-1/2 | Calcium-Base | Refer to the grease manufacturer's specifications for the temperature service limits. |
| | 0-641 | — | Anti-Seize | |

*Do not mix Meritor grease specification 0-637, part number 2297-U-4571, a calcium-base, rust-preventive grease, with other greases.

Replacement Parts

Always use the component equipment manufacturer recommended quality standard parts. Meritor brakes work as a system, and when you replace original parts with “will-fit” parts, you can compromise the performance of the entire system.

Return Springs

Replace cam brake return springs at every cam brake reline. The return spring is critical to alignment, accurate return of the brake away from the drum and correct automatic slack adjustment.

Trailer Cam Brakes

Long-life bushings require correct lubrication for maximum performance and bushing life. Although you do not have to replace spider cam bushings on trailer axles as frequently, Meritor recommends that you lubricate the bushings at least four times during the life of your brake lining.

Automatic Slack Adjusters

Automatic doesn't mean maintenance-free. Correctly-installed and lubricated automatic slack adjusters help to ensure maximum brake system performance.

Never mix automatic slack adjusters on the same axle. When you replace automatic slack adjusters, always use the replacement parts that were originally designed for the brake system to help ensure even brake wear, balanced braking and maximum brake performance.

7 Brakes

Table BC: Approved Greases for Q Plus™ LX500 and MX500

| Lubricant | Recommendation |
|--------------------|--|
| 0-617-A 0-617-B | Multi-Purpose Lithium Chassis Grease |
| 0-645 | Mobilgrease 28 (Military) Mobiltemp SHC 32 (Industrial) Aerospace Lubricants Inc. Tribolube 12-Grade 1 |
| 0-692 | Amoco Super Permalube™ Grade 2 Citgo Premium Lithium EP-2 Grade 2 Exxon Ronex MP-2 Grade 2 Kendall L-427 Super Blu Grade 2 Mobilith AW-1 Grade 1 Sohio Factran EP-2 Grade 2 |
| 0-701 | EVO-LUBE TEK-664 |

Table BD: Q Plus™ LX500 and MX500 Greasing Specifications

| Component | Meritor Specification | NLGI Grade | Grease Description | Outside Temperature |
|---|-----------------------|------------|--|---|
| Camshaft Splines and Clevis Pins | 0-701 | 2 | Synthetic Oil, Calcium-Base | Down to –65°F (–54°C) |
| Anchor Pins When the brake is disassembled, or when necessary, lubricate the anchor pins where they touch the brake shoes. | 0-617-A | 1 | Lithium 12-Hydroxy Stearate or Lithium Complex | Refer to the grease manufacturer's specifications for the temperature service limits. |
| | or 0-617-B | 2 | | |
| | 0-645 | 2 | Synthetic Oil, Clay-Base | Down to –65°F (–54°C) |
| | 0-692 | 1 and 2 | Lithium-Base | Down to –40°F (–40°C) |
| Shoe Rollers When the brake is disassembled, or when necessary, lubricate the rollers where they touch the brake shoes. DO NOT get grease on the part of the roller that touches the cam head. | 0-617-A | 1 | Lithium 12-Hydroxy Stearate or Lithium Complex | Refer to the grease manufacturer's specifications for the temperature service limits. |
| | or 0-617-B | 2 | | |
| Automatic Slack Adjusters | 0-701 | 2 | Synthetic Oil, Calcium-Base | Down to –65°F (–54°C) |

Important Information

Meritor automatic slack adjusters (ASAs) should not need to be manually adjusted in service. ASAs should not have to be adjusted to correct excessive pushrod stroke. The excessive stroke may be an indication that a problem exists with the foundation brake, ASA, brake actuator or other system components.

Meritor recommends troubleshooting the problem, replacing suspect components and then confirming proper brake operation prior to returning the vehicle into service.

In the event that a manual adjustment must be made (although not a common practice), a service appointment and full foundation brake, ASA, and other system component inspection should be conducted as soon as possible to ensure integrity of the overall brake system.

For Meritor brake adjustment, refer to the brake adjustment tables in this section. For non-Meritor brake adjusters, refer to the brake manufacturer's service procedures.

Cam Brake Troubleshooting

Diagnostic Charts

Table BE: Cam Brake, All Models

| Symptoms | Possible Causes | Corrective Actions |
|-----------------------------|--|---|
| Adjusted stroke is too long | Incorrect slack adjuster part number | Check with the warehouse distributor or original equipment manufacturer. |
| | Clevis installed at the incorrect angle | Use the correct template or BSAP setting to install the clevis correctly. |
| No adjustment | Excessive wear between the clevis and collar, more than 0.060-inch (1.52 mm) | Replace with a threaded clevis. |
| | Loose jam nut at clevis | Tighten to specification. |
| | Worn clevis pin bushing in slack arm, inside diameter larger than 0.53-inch (13.46 mm) | Replace the bushing. |
| | Weak or broken return spring in air chamber, spring force must be at least 32 lb (142.4 N•m) at first push rod movement | Replace the return spring or air chamber. |
| | Spring brake does not retract fully | Repair or replace the spring brake. |
| | Worn or stripped teeth on pawl or actuator | Replace the slack adjuster. |
| | High torque is required to rotate the worm when slack is removed from vehicle | Replace the slack adjuster. |
| | <ul style="list-style-type: none"> • In service slack, maximum worm torque: 45 lb-in (5.09 N•m) • New or rebuilt slack, maximum worm torque: 25 lb-in (2.83 N•m) | |
| | Excessive looseness between camshaft splines and automatic slack adjuster gear | Replace the powershaft, gear or automatic slack adjuster as needed. |
| | Worn components, cam bushing, for example, in the foundation brake | Replace the components. |

7 Brakes

Table BE: Cam Brake, All Models

| Symptoms | Possible Causes | Corrective Actions |
|------------------------------|--|--|
| Adjusted stroke is too short | Non-original equipment manufacturer replacement linings with excessive swell or growth | Use Meritor-approved linings. |
| Linings drag | Incorrect slack adjuster part number | Check with the warehouse distributor or original equipment manufacturer. |
| | Clevis installed at the incorrect angle | Use the correct template to install the clevis correctly. |
| | Loose jam nut at clevis | Tighten to specification. |
| | Spring brake does not retract fully | Repair or replace the spring brake. |
| | Incorrect manual adjustment | Adjust the brake. |
| | Poor contact between linings and drum, or drum is out-of-round | Repair or replace the drums or linings. |
| | Brake temperature imbalance | Correct the brake balance. |

Air Disc Brakes

Technical Publications

How to Obtain Additional Maintenance and Service Information

Refer to the publications in Table BF. To obtain these publications, refer to the Service Notes page on the front inside cover of this manual.

Table BF: Publications

| Model | Manual |
|----------------------------|---------------------------------|
| ADB Series Air Disc Brakes | Maintenance Manual 4M |
| Air Disc Brakes | Failure Analysis Manual TP-0445 |

Description

How an Air Disc Brake Functions

When you apply the brakes, the air chamber push rod pushes the automatic slack adjuster mounted to the camshaft, which rotates the camshaft and causes the camshaft nut to slide outward along the camshaft. Figure 7.15.

The camshaft nut moves the piston and the inboard lining against the disc, and this force pulls the caliper inward along the slide pins.

The caliper movement enables the outboard pad to contact the disc, which results in a clamping force on both sides of the disc.

When you release the brakes, the piston return spring retracts the piston, which forces the camshaft nut back into its starting position, and releases the clamping force of the disc.

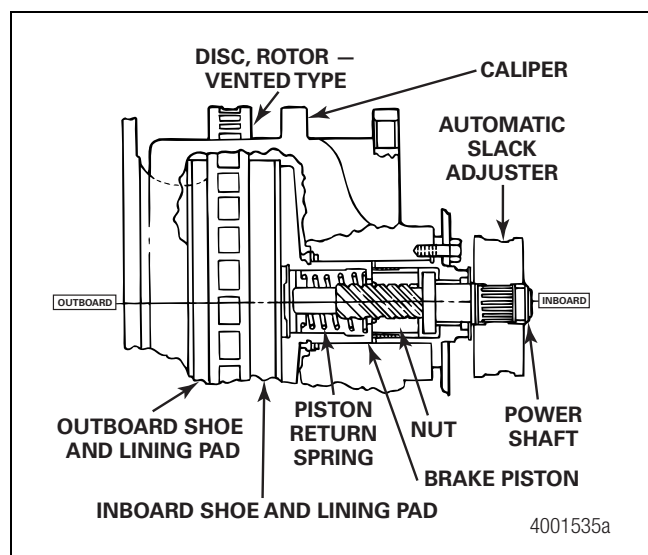

Figure 7.15

Features

Dura-Master® Model ADB 1560

- An easily-visible indicator to detect lining wear
- A caliper that pivots away from the disc for quick shoe and lining changes
- Meritor automatic slack adjuster
- A caliper that's sealed and lubricated to protect components that actuate the brake
- Standard-service air chambers, or air chambers with springs

DiscPlus™ DX195 and DX225 Air Disc Brakes

DX195 and DX225 air disc brakes are optional on FF and FG front steer axles. Brakes feature sealed calipers lubricated to protect components that actuate the brake. The brake is comprised of a lightweight single-piece cast caliper supported on twin fully seated slide pins fixed to a mounting saddle. Figure 7.16.

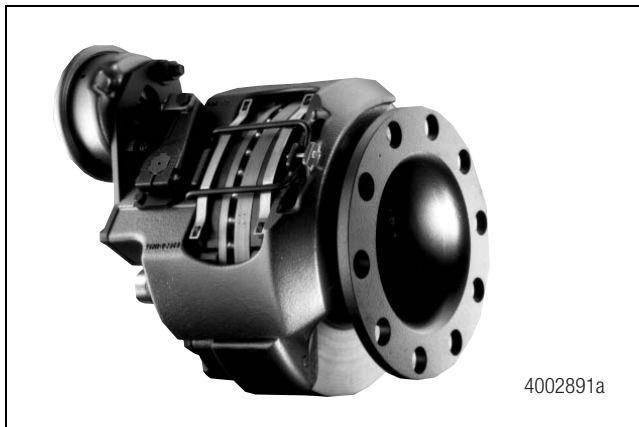

Figure 7.16

Identification

Dura-Master® ADB 1560 Air Disc Brake

- A model number tag is attached to the grease fitting on the brake caliper assembly.
- An example of a part number format for an ADB 1560 brake is ADB 1560 1234.

DiscPlus™ Air Disc Brake

- A model number tag is attached to the top surface of the caliper.
- An example of a part number format for a DiscPlus™ brake is DX 195 1234.

Model Nomenclature

Refer to Figure 7.17 and Figure 7.18 for an explanation of model numbers.

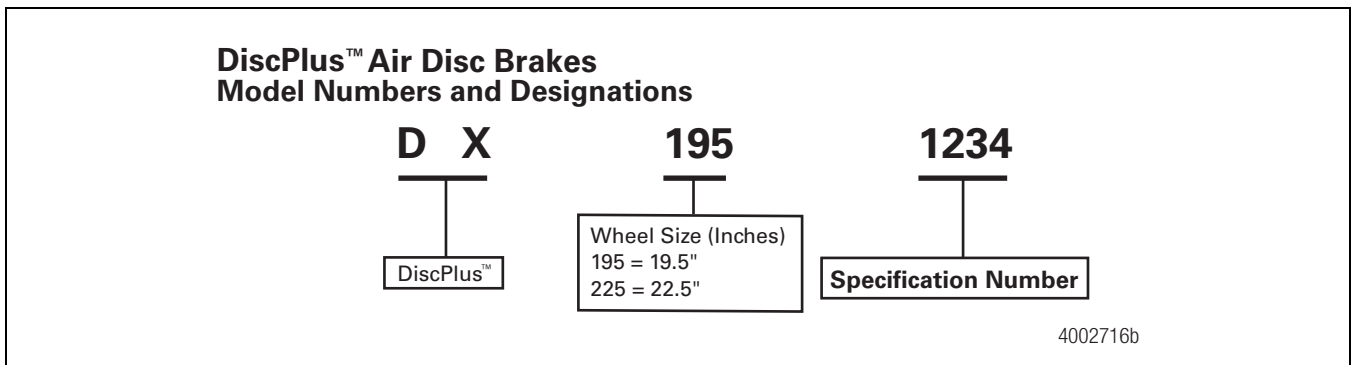

Figure 7.17

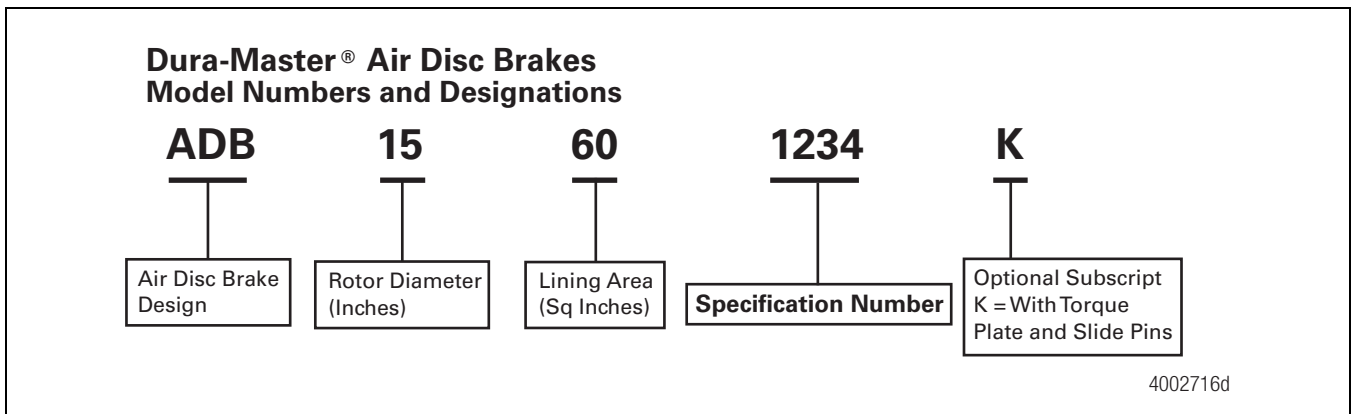

Figure 7.18

7 Brakes

Air Disc Brake Inspection Intervals and Procedures

Inspection Schedules

Use the schedule below that gives the most frequent inspection.

- Fleet chassis lubrication schedule
- Chassis manufacturer lubrication schedule
- At least four times during the lining life
- At tire replacement

Minor Inspections

The maintenance schedules shown in this manual are for normal operating conditions. Refer below for other operating conditions.

- Operation under severe conditions can require shorter periods between maintenance.
- Operation over long distances with few stops can permit longer periods between maintenance.

A maintenance schedule for each vehicle can be set after the brakes are inspected several times.

Major Inspections

Inspect and lubricate the brake and automatic slack adjuster according to one of the following schedules. Use the schedule that provides the most frequent inspection and lubrication.

- The chassis lubrication schedule used by your fleet.
- The chassis lubrication schedule recommended by the chassis manufacturer.
- A minimum of four times during the life of the linings.

Air System

- A vehicle equipped with a combination of air disc and drum brakes requires special attention to obtain maximum brake performance.
- Replace the air system valves with valves of identical performance characteristics.
- A correctly maintained air system and correct air pressure to each brake can help to ensure maximum brake performance and reduced lining wear.

Automatic Slack Adjusters

Refer to Automatic Slack Adjusters in this section.

Slide Pins and Bushings: Air Disc Brake Model ADB 1560

1. Check for contamination on the slide pins. If necessary, remove and clean the slide pins and caliper bushings.
2. Use a pin gauge J-34064-54, to check the slide pin bushings for wear. If you can fit the gauge between the slide pin and the bushing, the bushing or slide pin is worn. Replace worn bushings and slide pins. To obtain the pin gauge, contact SPX Kent-Moore at 800-328-6657.

Rotors

Inspect the rotor for cracks, deep scores or other damage. Replace the rotor when necessary.

Air Chamber

Move the air chamber from side-to-side to check that the caliper moves freely on the slide pins. When the caliper does not move freely, inspect the slide pins, slide pin bushings and slide pin retainers for wear or damage. Replace components when necessary.

Linings

When the linings wear, the caliper slides in along the slide pins. To check for lining wear, check the position of the caliper inboard bosses on the slide pins. Figure 7.19. If the bosses are within 0.25-inch (6.4 mm) of the ends of the pins, remove the wheels and tires and inspect the linings. If the bosses are within 0.125-inch (3.2 mm) of the ends of the pins, replace the linings.

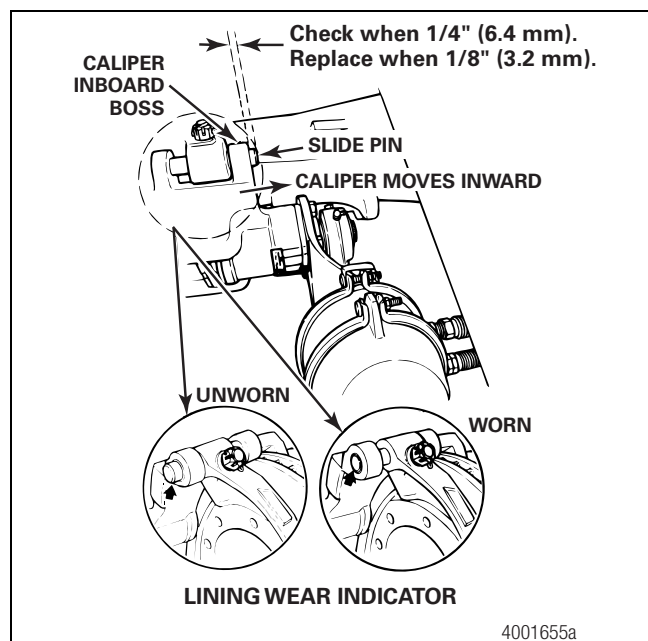

Figure 7.19

Major Inspections

When you reline the brakes, or at least one time a year, perform the following inspection.

1. Inspect the automatic slack adjuster and brakes as previously described in Minor Inspections. Perform minor inspections before you do any other maintenance or reline procedures.
2. Perform all the procedures, inspections and measurements.
3. Lubricate the automatic slack adjuster and the caliper.
4. Adjust the brakes.

Important Information

Meritor automatic slack adjusters (ASAs) should not need to be manually adjusted in service. ASAs should not have to be adjusted to correct excessive pushrod stroke. The excessive stroke may be an indication that a problem exists with the foundation brake, ASA, brake actuator or other system components.

Meritor recommends troubleshooting the problem, replacing suspect components and then confirming proper brake operation prior to returning the vehicle into service.

In the event that a manual adjustment must be made (although not a common practice), a service appointment and full foundation brake, ASA, and other system component inspection should be conducted as soon as possible to ensure integrity of the overall brake system.

For Meritor brake adjustment, refer to the brake adjustment tables in this section. For non-Meritor brake adjusters, refer to the brake manufacturer's service procedures.

Commercial Vehicle Safety Alliance (CVSA) Guidelines

Use the following procedure to check in-service push rod travel or adjusted chamber stroke on Meritor air disc brake Model ADB 1560.

WARNING

Before you service a spring chamber, carefully follow the manufacturer's instructions to compress and lock the spring to completely release the brake. Verify that no air pressure remains in the service chamber before you proceed. Sudden release of compressed air can cause serious personal injury and damage to components.

1. The engine must be OFF. If the brake has a spring chamber, follow the manufacturer's instructions to release the spring. Verify that no air pressure remains in the service section of the chamber.

2. Verify that pressure is 100 psi (689 kPa) in the air tanks. Determine the size and type of brake chambers on the vehicle.
3. With the brakes released, mark the push rod where it exits the chamber. Measure and record the distance. Have another person apply and hold the brakes on full application. Figure 7.20. Hold the ruler parallel to the push rod and measure as carefully as possible. A measurement error can affect CVSA re-adjustment limits. CVSA states that "any brake 1/4-inch or more past the re-adjustment limit, or any two brakes less than 1/4-inch beyond the re-adjustment limit, will be cause for rejection."

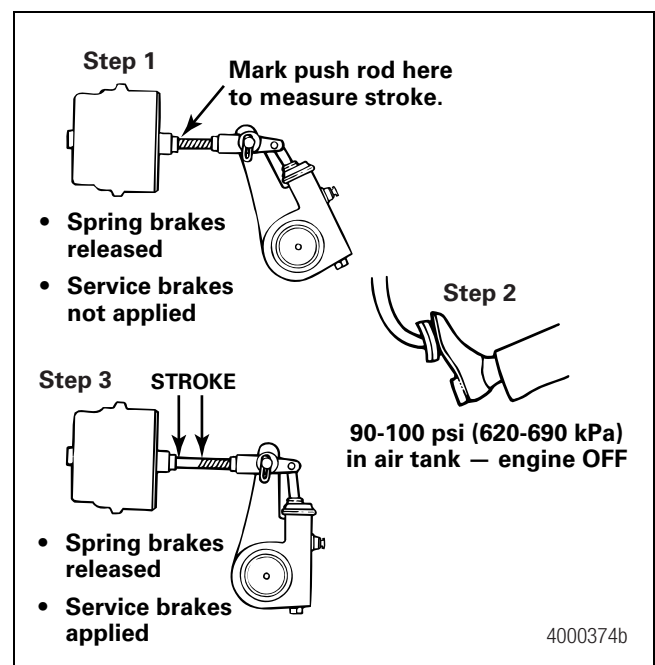

Figure 7.20

4. Measure the push rod travel or adjusted chamber stroke from where the push rod exits the brake chamber to your mark on the push rod. Measure and record the distance. Figure 7.20.
5. Subtract the measurement you recorded in Step 3 from the measurement you recorded in Step 4. The difference is the push rod travel or adjusted chamber stroke.
6. Refer to Table BG or Table BH to verify that the stroke length is correct for the size and type of air chambers on the vehicle.
 - If the adjusted chamber stroke is greater than the maximum stroke shown in Table BG or Table BH: Refer to Brake Diagnostic Charts, Table BJ, in this section.

7 Brakes

Table BG: Standard-Stroke Clamp-Type Brake Chamber Data

| Type | Outside Diameter (inches) | Brake Adjustment Limit (inches) |
|------|---------------------------|---------------------------------|
| 6 | 4-1/2 | 1-1/4 |
| 9 | 5-1/4 | 1-3/8 |
| 12 | 5-4/16 | 1-3/8 |
| 16 | 6-3/8 | 1-3/4 |
| 20 | 6-25/32 | 1-3/4 |
| 24 | 7-7/32 | 1-3/4 |
| 30 | 8-3/32 | 2 |
| 36 | 9 | 2-1/4 |

Table BH: Long-Stroke Clamp-Type Brake Chamber Data

| Type | Outside Diameter (inches) | Brake Adjustment Limit (inches) |
|------|---------------------------|---------------------------------|
| 16 | 6-3/8 | 2.0 |
| 20 | 6-25/32 | 2.0 |
| 24 | 7-7/32 | 2.0 |
| 24* | 7-7/32 | 2.5 |
| 30 | 8-3/32 | 2.5 |

* For 3" maximum stroke type 24 chambers.

Alternate Method to Measure Push Rod Travel (Adjusted Chamber Stroke)

Use the CVSA procedure, except in Steps 3-4, measure the distance from the bottom of the air chamber to the center of the large clevis pin on each of the brakes.

CVSA North American Out-of-Service Criteria Reference Tables

Information contained in Table BG and Table BH is for reference only. Consult the CVSA's Out-of-Service Criteria Handbook for North American Standards, Appendix A. Visit their website at <http://64.35.82.7/> to obtain the handbook.

Important Information

Meritor automatic brake adjusters (ABAs) should not need to be manually adjusted in service. ABAs should not have to be adjusted to correct excessive pushrod stroke. The excessive stroke may be an indication that a problem exists with the foundation brake, ABA, brake actuator or other system components.

Meritor recommends troubleshooting the problem, replacing suspect components and then confirming proper brake operation prior to returning the vehicle into service.

In the event that a manual adjustment must be made (although not a common practice), a service appointment and full foundation brake, ABA, and other system component inspection should be conducted as soon as possible to ensure integrity of the overall brake system.

For Meritor brake adjustment, refer to the brake adjustment tables in this section. For non-Meritor brake adjusters, refer to the brake manufacturer's service procedures.

Checking the Adjusted Chamber Stroke Length on DiscPlus™ DX195 and DX225 Air Disc Brakes

Use the following procedures to check in-service push rod travel.

1. The engine must be off.
2. Check the gauges in the cab to ensure that the air pressure in the tanks is between 90-100 psi (620-689 kPa).
3. Measure the distance from the bottom of the air chamber to the center of the clevis pin while the brakes are released. Figure 7.21.

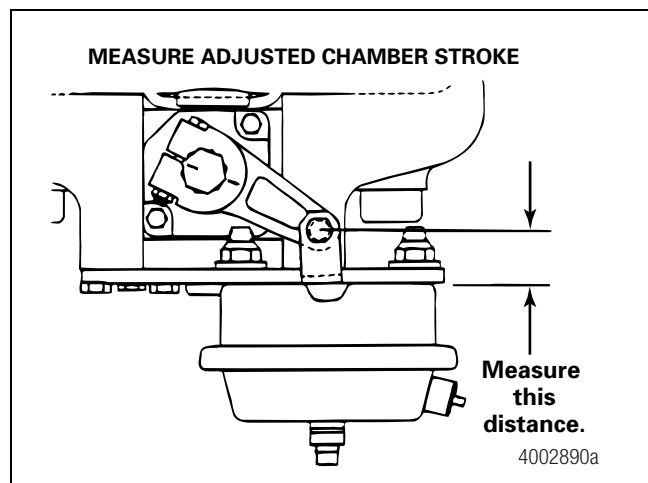

Figure 7.21

4. Have another person apply and hold the brakes on full application.
5. Measure the distance from the bottom of the air chamber to the center of the clevis pin while the brakes are applied.
6. **To determine push rod travel, adjusted chamber stroke:** Subtract the measurement you obtained in Step 2 from the measurement you obtained in Step 5. The difference is the push rod travel, adjusted chamber stroke.
 - A. Push rod travel, adjusted chamber stroke, must not be greater than two-inches (50.8 mm) for the type 16 and 20 long-stroke chambers used on these axles.
 - B. If push rod travel, adjusted chamber stroke, is greater than the maximum stroke, refer to Condition 1 in Table BK for more information.

DiscPlus™ DX195 and DX225 Air Disc Brake Components

Lining Thickness

Lining material thickness must not be less than 0.200-inch (5.1 mm). Replace the linings before the lining material thickness reaches this specification.

Anti-Rattle Springs

1. Anti-rattle springs are attached to the linings. Inspect for bent, cracked or broken springs.
2. If you find damaged springs, replace the springs.

Seals

Replace the caliper if you find cracked, torn or otherwise damaged seals.

Caliper

The caliper should slide freely on the slide pins. Slide the caliper back and forth to check for clearance between the disc, rotor, and pad.

Disc and Rotor

⚠ CAUTION

Always replace a cracked disc to avoid serious personal injury and damage to components.

Inspect both sides of the disc, rotor, for the following conditions. Replace the disc, rotor, if necessary.

- When a crack extends through a section of the disc, rotor, replace the disc, rotor.
- Heat checks are short, thin, sometimes numerous radial interruptions of the braking surfaces of the rotor. They are a normal phenomena of the disc brake function. They are the result of the heating and cooling that occurs as brakes are applied time after time. Heat checks will frequently wear away and reform or they may progress into braking surface cracks, depending on such factors as the lining/rotor wear rate, brake balance and how hard the brakes are used. There are two kinds of heat checking: light and heavy.
- Cracks on the surface of the disc, rotor, that result from light heat checking are small and fine and do not require disc, rotor, replacement.
- Heavy heat checking is surface cracks that have width and depth. If you find heavy heat checking, replace the disc, rotor.
- Inspect both sides of the disc, rotor. If you find deep grooves or scores, replace the disc, rotor. If the grooves or scores are not too deep, you can continue to use the disc.
- Blue marks or bands indicate that the disc, rotor, was very hot. Refer to Conditions 2, 3 and 4 in Table BK to determine the cause and correct the condition.
- Measure the thickness of the disc, rotor, when you reline the brakes. The disc, rotor, must be at least 1.626-inches (41.3 mm). Figure 7.22. If the thickness of a disc, rotor, is less than the specification, replace the disc, rotor.

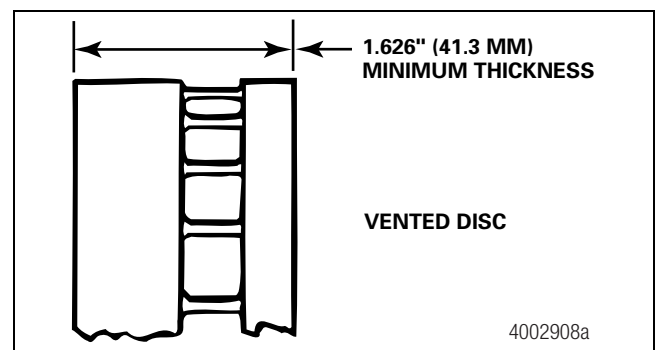

Figure 7.22

7 Brakes

Air Disc Brake Model ADB 1560 Lubrication Intervals and Procedures

Lubrication Procedures

⚠ CAUTION

Do not use lithium-based grease inside the caliper. Lithium-based grease may not adequately lubricate the caliper. Damage to the caliper can result. Some lithium-based greases can be used in the automatic slack adjuster. Refer to the approved lithium-based greases for automatic slack adjusters.

Lubricate the Automatic Slack Adjuster

Use a grease gun to lubricate the automatic slack adjuster through the grease fitting until new grease flows from the pressure relief seal under the pawl assembly.

Anti-Seize Compound

Meritor lubricant specification 0-637, part number 2297-U-4571, is a corrosion-control grease. Do not mix this grease with other greases. This compound is also available from the Southwest Petro-Chemical Division of Witco Chemical Corporation, 1400 South Harrison, Olathe, KS 66061, as Corrosion Control, part number SA 8249496.

- Use anti-seize compound on the clevis pins of all slack adjusters.
Also use anti-seize compound on the automatic slack adjuster and cam splines if the slack adjuster gear has no grease groove and holes around its inner diameter.

Lubricate the Caliper

⚠ CAUTION

Only use Meritor specification 0-616-A or 0-645 grease inside the disc brake caliper. Do not use lithium-base grease, which can melt from high temperatures inside the caliper. Damage to components can result.

Meritor air disc brakes have been manufactured in three designs. Note that the location of the caliper grease fitting and pressure relief valve is different in brakes manufactured before 1985, from 1985 to 1991, and after 1992. Figure 7.23, Figure 7.24 and Figure 7.25.

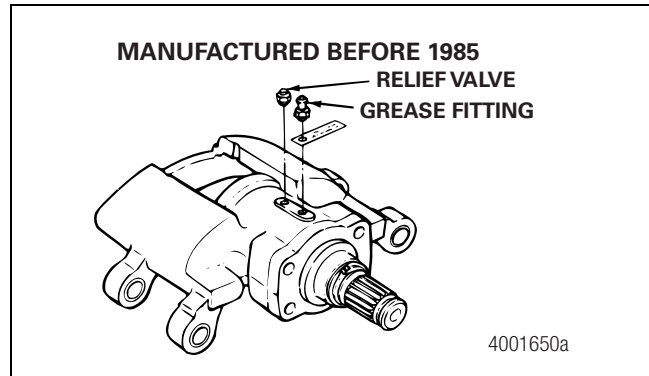

Figure 7.23

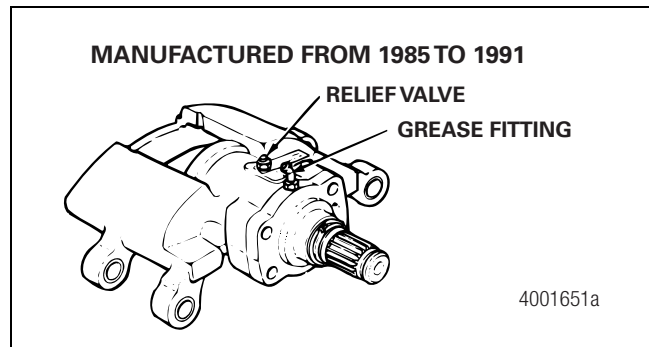

Figure 7.24

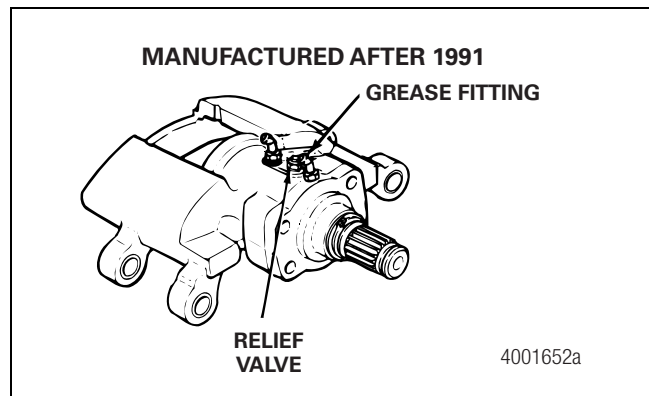

Figure 7.25

Lubricate brake-actuating components inside the caliper two to four times during the life of the lining, or every six months.

1. Turn the adjusting nut on the automatic slack adjuster to move the inboard lining against the rotor. Figure 7.26.

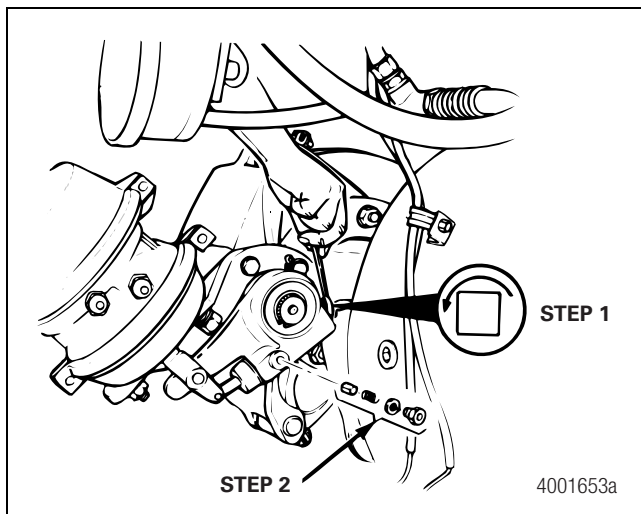

Figure 7.26

2. Plug the pressure relief valve by holding a finger over the poppet.

Approved Lubricants

Table BI: Air Disc Brake Model ADB 1560 Grease Specifications

| Component | Meritor Specification | NLGI Grade | Grease Description | Outside Temperature |
|----------------------|-----------------------|----------------|--------------------------|---|
| Caliper ¹ | 0-616-A | 1 | Clay Base | Down to -40°F (-40°C) |
| | 0-645 | 2 | Synthetic Oil, Clay Base | Down to -65°F (-54°C) |
| Slide Pin Retainers | 0-637 ² | 1-1/2 | Calcium Base | Refer to the grease manufacturer's specifications for the temperature service limits. |
| | 0-641 | — | Anti-Seize | |
| Powershaft Splines | Any of Above | Refer to Above | Refer to Above | Refer to Above |

¹ The grease used inside the caliper must be non-melting and also allow correct brake function at cold temperatures listed.

² Do not mix 0-637 calcium-base, corrosion-control grease with other greases.

NOTE: For calipers with grease fittings in the caliper and the camshaft cap, first apply grease to the caliper fitting, then apply grease to the camshaft cap fitting.

3. Apply grease through the grease fitting in the caliper until grease flows out of the seal at the camshaft cap.

CAUTION

You must force excess grease from the caliper. Brakes can drag due to excessive grease in the caliper, which will reduce brake lining life.

4. Remove the pressure relief valve from the caliper. Turn the slack adjuster adjusting nut in the opposite direction to fully retract the caliper piston and force the excess grease through the pressure relief hole.
5. Clean the excess grease from the outside of the caliper with a rag.
6. Install the pressure relief valve.
7. Adjust the brake.

7 Brakes

Important Information

Meritor automatic slack adjusters (ASAs) should not need to be manually adjusted in service. ASAs should not have to be adjusted to correct excessive pushrod stroke. The excessive stroke may be an indication that a problem exists with the foundation brake, ASA, brake actuator or other system components.

Meritor recommends troubleshooting the problem, replacing suspect components and then confirming proper brake operation prior to returning the vehicle into service.

In the event that a manual adjustment must be made (although not a common practice), a service appointment and full foundation brake, ASA, and other system component inspection should be conducted as soon as possible to ensure integrity of the overall brake system.

For Meritor brake adjustment, refer to the brake adjustment tables in this section. For non-Meritor brake adjusters, refer to the brake manufacturer's service procedures.

Air Disc Brake Troubleshooting

Brake Diagnostic Charts

Table BJ: Air Disc Brake

| Conditions | Possible Causes | Check For | Corrections |
|--|---|---|---|
| Poor stopping power <ul style="list-style-type: none"> • Long stopping distances • Poor driver feel • High brake pressures | Incorrect air chamber or slack adjuster size | Check with vehicle manufacturer or Meritor for correct chamber and slack adjuster size. | Replace equipment with the recommended size. |
| | Vehicle air system malfunction | Correct air pressure at the chamber inlet | Have the air system evaluated by a qualified brake system specialist. |
| | Brakes out-of-adjustment | Stroke | Repair, replace parts as required. |
| | | Installation with auto slack template | Adjust to the recommended stroke. |
| | | Jam nut torque | Correct the set-up and check with the template. |
| Poor grade holding ability <ul style="list-style-type: none"> • Vehicle does not hold on typical grade | Vehicle overload | Clevis wear | Tighten as required. |
| | Contamination on the linings | Pawl wear | Observe the vehicle manufacturer's load recommendations. |
| | Companion vehicle brakes not working correctly | Overloading — see GAWR limitations on vehicle I.D. plate. | Replace the linings. |
| | Refer to Poor stopping power | Grease, oil, etc., on the linings | Adjust or repair as required. |
| | Incorrect spring brake chamber size | Inspect the companion vehicle brakes and air system. | As required. Refer to Poor stopping power. |
| Brake not functioning <ul style="list-style-type: none"> • Lack of normal response | Spring brake power spring in the caged position | — | Replace with the correct chamber as required. |
| | Refer to Poor stopping power | — | Uncage the power spring. |
| | Internal caliper failure | — | As required. Refer to Poor stopping power. |
| | | Movement of the load plate piston when actuating the automatic slack adjuster | Disassemble and overhaul the caliper. |

Table BJ: Air Disc Brake

| Conditions | Possible Causes | Check For | Corrections |
|--|---|---|---|
| Vehicle pulls to one side when stopping | Refer to Poor stopping power, Poor grade holding ability and Brake not functioning. | — | Refer to Poor stopping power, Poor grade holding ability and Brake not functioning. |
| Brake drag | Incorrect manual adjustment | Automatic slack adjuster set-up Correct running clearance pad-to-disc or rotor | Correct the set-up. Adjust to the recommended stroke and running clearance. Check with the template. |
| <ul style="list-style-type: none"> • Evidence of severe heat • Rapid lining wear • Heavy blueing or discoloration of disc or rotor braking surface • Torn or charred piston or caliper boot seal | Vehicle air system malfunction | Correct operation of the quick release valve and relay valve | Repair or replace parts as required. |
| | Spring brake not releasing | Vehicle air system leakage | Find the source of the leak and repair as required. |
| | | Spring brake chamber malfunction | Repair or replace the spring brake chamber as required. |
| | | Slow build-up of trailer emergency air pressure | Wait for full build-up before driving. |
| | | Incorrect air pressure range at compressor or governor | Set the compressor or governor to the correct pressure range. |
| | Excessive grease pressure in the caliper | Incorrect lubrication procedures | Follow the lubrication recommendations. |
| | Internal corrosion of caliper assembly | Piston boot and caliper seals | Replace the seals as required. Inspect and overhaul the caliper assembly as required. |
| Short outboard lining life | Caliper seized on slide pins | Excessive paint or other foreign build-up on the caliper slide pins or bushings | Remove both pins. Clean, inspect and replace the pins and bushings as required. |
| <ul style="list-style-type: none"> • Brake drag | Misalignment of slide pins | Caliper should move back and forth with hand effort, 20-30 lb-ft (27-41 N•m) | Remove the pads. Clean, inspect and replace the slide pins and bushings as necessary. Install the caliper and slide pins without the pads. Tighten the retainer nuts. Check that the caliper slides freely on the slide pins. If the problem continues, check the axle mounting flange for nicks, burrs or gouges. Repair as necessary. Install the torque plate and caliper and check again for free movement. If the flange is acceptable but the problem continues, contact your Meritor representative for information. |

7 Brakes

Table BJ: Air Disc Brake

| Conditions | Possible Causes | Check For | Corrections |
|--|---|---|---|
| Short lining life | Refer to Brake drag and Short outboard lining life. | — | Refer to Brake drag and Short outboard lining life. |
| | Abusive use of brake system | Driver technique | Train the drivers. |
| | Vehicle overload | Overloading. Refer to gross axle weight ratings (GAWR) limitations on vehicle identification plate. | Observe the vehicle manufacturer's load recommendations. |
| Pad backing plate tab wear | Companion vehicle brakes do not work correctly | Inspect companion vehicle brakes and air system. | Adjust or repair as required. |
| | Brinnelling of pad tab area | Signs of brinnelling and back-and-forth movement of the pad in the caliper | Remove and replace the pads. Check the anti-rattle clip. If wear is excessive, replace the caliper assembly. |
| Fractured disc or rotor • Cracked or broken | Refer to Brake drag, Short outboard lining life and Short lining life. | — | Replace the disc or rotor, shoes and linings as required. Review the correct maintenance procedures with personnel. |
| | Failure to perform routine checks on lining wear and caliper position on slide pins | Disc or rotor for minimum thickness | |
| Slide pin or retainer pin assemblies hard to remove | Highly corrosive environment | Signs of corrosion | Inspect the slide pins and retainer pin assemblies. Replace as required. Apply an anti-seize compound to the retainer, but not to the threads. Seal the inner end of the lower slide pin retainer hole in the torque plate. |
| Brake smoking | Leaking hub or wheel seal | Condition of seals | Replace as required. Clean the disc or rotor as required. Inspect the pads and replace if oil-soaked. |
| | Leaking caliper sealing components | Condition of piston boot, piston cap seal and piston or caliper seal | Replace as required. |
| | Piston boot popped out of piston seating groove | Excessive lubrication of caliper. Inspect piston boot position. | Follow the lubrication recommendation. Replace the piston boot if required. |
| | Paint on slide pins or brake | All painted surfaces | Clean the slide pins and brake as required. |
| | High brake temperature | Refer to Poor stopping power, Brake drag, Short outboard lining life and Short lining life. | Refer to Poor stopping power, Brake drag, Short outboard lining life and Short lining life. |

Important Information

Meritor automatic brake adjusters (ABAs) should not need to be manually adjusted in service. ABAs should not have to be adjusted to correct excessive pushrod stroke. The excessive stroke may be an indication that a problem exists with the foundation brake, ABA, brake actuator or other system components.

Meritor recommends troubleshooting the problem, replacing suspect components and then confirming proper brake operation prior to returning the vehicle into service.

In the event that a manual adjustment must be made (although not a common practice), a service appointment and full foundation brake, ABA, and other system component inspection should be conducted as soon as possible to ensure integrity of the overall brake system.

For Meritor brake adjustment, refer to the brake adjustment tables in this section. For non-Meritor brake adjusters, refer to the brake manufacturer's service procedures.

DiscPlus™ DX195 and DX225 Air Disc Brakes

Table BK: DiscPlus™ DX195 and DX225 Air Disc Brakes

| Condition | Possible Causes | Check For | Actions Required |
|---|--|--|---|
| 1 — Air chamber exceeds 2-inch maximum stroke requirement at 90-100 psi (620-689 kPa) in cab | Incorrect initial adjustment or inoperative automatic adjuster | Recheck chamber stroke after 20 brake applications. | If the air chamber still overstrokes, then replace the caliper/saddle assembly. |
| 2 — Brake drag | Incorrect lining-to-rotor clearance Incorrect initial adjustment Vehicle air system malfunction | Minimum stroke at 90-100 psi (620-689 kPa) in cab to be 7/8-inch (22 mm) Correct operation of quick release valve | Replace the caliper/saddle assembly. Readjust the rotor-to-pad clearance. Repair or replace the parts as required. |
| 3 — Short outboard brake pad lining life | Caliper seized or sticking on slide pins | Damaged slide-pin seals. Caliper should move back-and-forth by hand with linings removed. | Repair the caliper/saddle assembly. |
| 4 — Short lining life | Refer to conditions 2 and 3. Rotor surface Vehicle overload Companion brakes not working correctly. | Refer to conditions 2 and 3. Cracks or heavy heat checking. Refer to condition 3. Refer to GAWR limitations on vehicle I.D. plate. Inspect companion vehicle brakes and air system. | Refer to conditions 2 and 3. Refer to conditions 3 and 4 for disc, rotor, inspection. Observe the vehicle manufacturer's load recommendations. Adjust or repair as required. |
| 5 — Brake smoking | High brake temperature Contamination on linings | Refer to conditions 2, 3 and 4. Grease, oil, etc., on linings | Refer to conditions 2, 3 and 4. Inspect the hub seal. Replace as required. Clean the rotor and caliper assembly. Replace linings. |

7 Brakes

Table BK: DiscPlus™ DX195 and DX225 Air Disc Brakes

| Condition | Possible Causes | Check For | Actions Required |
|--|---|--|---|
| 6 — Poor stopping power <ul style="list-style-type: none"> • Long stopping distances • Poor driver feel • High brake pressures • Lack of normal response • Vehicle pulls to one side | Vehicle air systems malfunction Brakes out of adjustment Vehicle overload Contamination on linings Companion brakes not working correctly | Correct air pressure at the chamber inlet Stroke exceeds 2-inch requirement. Refer to GAWR limitations on vehicle I.D. plate. Grease, oil, etc., on linings Inspect companion vehicle brakes and air system. | Have the air system evaluated by a qualified brake system specialist. Refer to condition 1. Observe the vehicle manufacturer's load recommendations. Observe the vehicle manufacturer's load recommendations. Adjust or repair as required. |
| 7 — Shimmy or brake pull | Refer to conditions 1, 2 and 6. Rotor runout and thickness variation | Refer to conditions 1, 2 and 6. | Refer to conditions 1, 2 and 6. Replace the hub and rotor assembly. |

Automatic Slack Adjusters

Important Information

Meritor automatic slack adjusters (ASAs) should not need to be manually adjusted in service. ASAs should not have to be adjusted to correct excessive pushrod stroke. The excessive stroke may be an indication that a problem exists with the foundation brake, ASA, brake actuator or other system components.

Meritor recommends troubleshooting the problem, replacing suspect components and then confirming proper brake operation prior to returning the vehicle into service.

In the event that a manual adjustment must be made (although not a common practice), a service appointment and full foundation brake, ASA, and other system component inspection should be conducted as soon as possible to ensure integrity of the overall brake system.

For Meritor brake adjustment, refer to the brake adjustment tables in this section. For non-Meritor brake adjusters, refer to the brake manufacturer's service procedures.

Technical Publications

How to Obtain Additional Maintenance and Service Information

Refer to the publications in Table BL. To obtain these publications, refer to the Service Notes page on the front inside cover of this manual.

Table BL: Publications

| Model | Manual |
|--|---------------------------------|
| Cam Brakes and Automatic Slack Adjusters | Maintenance Manual 4 |
| Automatic Slack Adjusters | Failure Analysis Manual TP-0445 |

Intervals

Inspect and lubricate the automatic slack adjuster according to one of the schedules below. Use the schedule that requires the most frequent inspection and lubrication, and whenever you reline the brakes. Refer to Table BM for grease specifications.

- Vehicle manufacturer's schedule
- Fleet's schedule
- Every six months
- A minimum of four times during the life of the linings

Identification

The part number is located on the side of the slack adjuster.

Meritor uses either black, red, yellow, green or blue to color-code the automatic slack adjuster internal actuator piston according to brake type and air chamber size.

A mylar tag is attached to the current-design slack adjuster with a press-in boot. The color of the actuator piston is printed on the mylar tag. Figure 7.27.

On previous-design slack adjusters, a color-coded tie wrap attaches the boot to the slack adjuster body. The color of the tie wrap matches the color of the actuator piston. Figure 7.27.

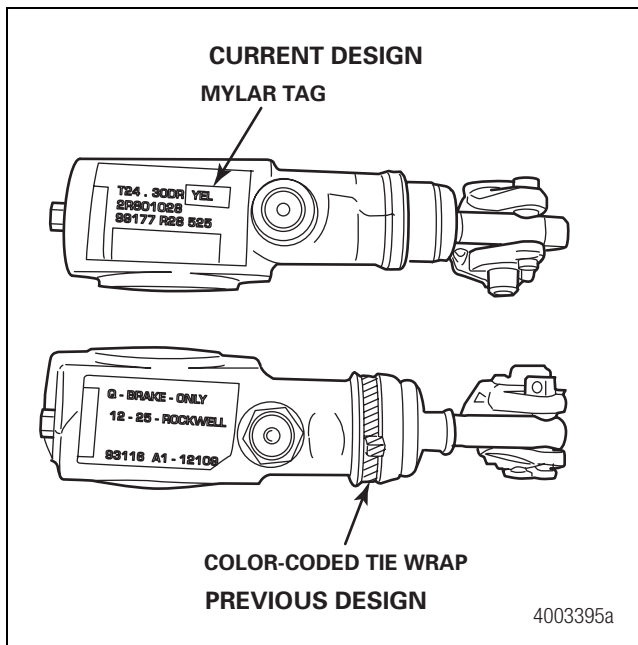

Figure 7.27

Procedures

⚠ WARNING

Park the vehicle on a level surface. Block the wheels to prevent the vehicle from moving. Support the vehicle with safety stands. Do not work under a vehicle supported only by jacks. Jacks can slip and fall over. Serious personal injury and damage to components can result.

1. Place blocks in front and behind the wheels to prevent the vehicle from moving.

⚠ WARNING

Before you service a spring chamber, carefully follow the manufacturer's instructions to compress and lock the spring to completely release the brake. Verify that no air pressure remains in the service chamber before you proceed. Sudden release of compressed air can cause serious personal injury and damage to components.

2. If the vehicle has spring brakes, manually compress and lock the springs to release the brakes. You must check to ensure that no air pressure remains in the service halves of the air chambers.

Slack Adjusters Manufactured in 1993

1. Use the correct slack adjuster template to ensure that the clevis is installed in the correct position.
2. Before you perform brake maintenance, check the free stroke and the adjusted chamber stroke.
3. If the free stroke is not correct, refer to the adjustment procedure in this section to correct the stroke before you adjust the chamber stroke.
4. Inspect the boot for cuts or other damage. If the boot is cut or damaged, remove the pawl and inspect the grease.
5. If the grease is in good condition, replace the damaged boot with a new boot.
6. Use a grease gun to lubricate the slack adjuster through the grease fitting. If necessary, install a camshaft into the slack adjuster gear to minimize grease flow through the gear holes.
7. Lubricate until the new grease purges from around the inboard camshaft splines and from the pawl assembly.

At Brake Reline

1. Before you perform brake maintenance, check the free stroke and the adjusted chamber stroke.
2. If the free stroke is not correct, refer to the diagnostic tables in this section to correct the stroke before you adjust the chamber stroke.
3. Inspect the boot for cuts or other damage. If the boot is cut or damaged, remove the pawl and inspect the grease.
4. If the grease is in good condition, replace the damaged boot with a new boot.
5. Use a grease gun to lubricate the slack adjuster through the grease fitting. If necessary, install a camshaft into the slack adjuster gear to minimize grease flow through the gear holes.
6. Lubricate until new grease purges from around the inboard camshaft splines and from the pawl assembly.

7 Brakes

Approved Lubricants

Table BM: Automatic Slack Adjuster Grease Specifications

| Components | Meritor Specification | NLGI Grade | Grease Type | Outside Temperature |
|--------------------------|------------------------------|-------------------|--------------------------|---|
| Automatic Slack Adjuster | O-616-A | 1 | Clay Base | Down to -40°F (-40°C) |
| | O-645 | 2 | Synthetic Oil, Clay Base | Down to -65°F (-54°C) |
| | O-692 | 1 and 2 | Lithium Base | Down to -40°F (-40°C) |
| Clevis Pins | Any of Above | Refer to Above | Refer to Above | Refer to Above |
| | O-637* | 1-1/2 | Calcium Base | Refer to the grease manufacturer's specifications for the temperature service limits. |
| | O-641 | — | Anti-Seize | |

*Do not mix Meritor grease specification O-637, part number 2297-U-4571, a calcium-base, rust-preventive grease, with other greases.

Table BN: Automatic Slack Adjuster Lubricant Specifications

Operating Temperature

Down to -40°F (-40°C)

Clay-Base Greases
 Meritor Specification O-616-A, Part Number A-1779-W-283
 Shell Darina Number 1
 Texaco Thermatex EP-1
 Texaco Hytherm EP-1
 Aralub 3837

Down to -65°F (-54°C)

Synthetic Greases
 Meritor Specification O-645, Part Number 2297-X-4574
 Mobilgrease 28 (Military)
 Mobiltemp SHC 32 (Industrial)
 Tribolube-12 Grade 1

Anti-Seize Compound

Meritor lubricant specification O-637, part number 2297-U-4571, is a corrosion-control grease. Do not mix this grease with other greases. This compound is also available from the Southwest Petro-Chemical Division of Witco Chemical Corporation, 1400 South Harrison, Olathe, KS 66061, as Corrosion Control, part number SA 8249496.

- Use anti-seize compound on the clevis pins of all slack adjusters.
- Also use anti-seize compound on the automatic slack adjuster and cam splines if the slack adjuster gear has no grease groove and holes around its inner diameter.

Important Information

Meritor automatic slack adjusters (ASAs) should not need to be manually adjusted in service. ASAs should not have to be adjusted to correct excessive pushrod stroke. The excessive stroke may be an indication that a problem exists with the foundation brake, ASA, brake actuator or other system components.

Meritor recommends troubleshooting the problem, replacing suspect components and then confirming proper brake operation prior to returning the vehicle into service.

In the event that a manual adjustment must be made (although not a common practice), a service appointment and full foundation brake, ASA, and other system component inspection should be conducted as soon as possible to ensure integrity of the overall brake system.

For Meritor brake adjustment, refer to the brake adjustment tables in this section. For non-Meritor brake adjusters, refer to the brake manufacturer's service procedures.

Automatic Slack Adjuster Troubleshooting

Diagnostic Charts

Table B0: Automatic Slack Adjuster

| Conditions | Possible Causes | Corrections | |
|--|--|--|---|
| Adjusted stroke is too long | Incorrect slack adjuster part number | Check with the warehouse distributor or original equipment manufacturer. | |
| | No adjustment | Clevis installed at the incorrect angle | Use the correct template or BSAP setting to install the clevis correctly. |
| | | Excessive wear between the clevis and collar, more than 0.060-inch (1.52 mm) | Replace with a threaded clevis. |
| | | Loose jam nut at clevis | Tighten to specification. |
| | | Worn clevis pin bushing in slack arm, inside diameter larger than 0.53-inch (13.46 mm) | Replace the bushing. |
| | | Weak or broken return spring in air chamber, spring force must be at least 32 lb (142.4 N•m) at first push rod movement | Replace the return spring or air chamber. |
| | | Spring brake does not retract fully | Repair or replace the spring brake. |
| | | Worn or stripped teeth on pawl or actuator | Replace the pawl or actuator. |
| | | High torque is required to rotate the worm when slack is removed from vehicle | Rebuild or replace the slack adjuster. |
| | | <ul style="list-style-type: none"> In service slack, maximum worm torque: 45 lb-in (5.09 N•m) New or rebuilt slack, maximum worm torque: 25 lb-in (2.83 N•m) | |
| Excessive looseness between camshaft splines and automatic slack adjuster gear | Replace the camshaft, gear or automatic slack adjuster as needed. | | |
| Worn components, cam bushing, for example, in the foundation brake | Replace the components. | | |
| Adjusted stroke is too short | Non-original equipment manufacturer replacement linings with excessive swell or growth | Use Meritor-approved linings. | |
| | Linings drag | Incorrect slack adjuster part number | Check with the warehouse distributor or original equipment manufacturer. |
| Clevis installed at incorrect angle | | Use the correct template to install the clevis correctly. | |
| Loose jam nut at clevis | | Tighten to specification. | |
| Spring brake does not retract fully | | Repair or replace the spring brake. | |
| Incorrect manual adjustment | | Adjust the brake. | |
| Poor contact between linings and drum, or drum is out-of-round | | Repair or replace the drums or linings. | |
| Brake temperature imbalance | | Correct the brake balance. | |

7 Brakes

Wedge Brakes

Technical Publications

How to Obtain Additional Maintenance and Service Information

Refer to the publications in Table BP. To obtain these publications, refer to the Service Notes page on the front inside cover of this manual.

Table BP: Publications

| Model | Manual |
|-------------------------|----------------------------|
| Wedge Brakes | Maintenance Manual 4R |
| Stopmaster® Wedge Brake | Maintenance Manual MM-0153 |

Description

Meritor Stopmaster® wedge brakes for on-highway vehicles are air-actuated and are available as single-actuated (RSA) and dual-actuated (RDA). Both models can be specified with 12-, 14- or 16-degree wedge angles. Figure 7.28.

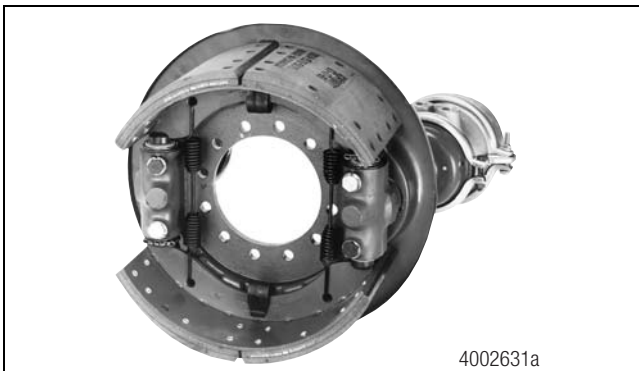

Figure 7.28

For complete maintenance and service information for Meritor wedge brakes, refer to Maintenance Manual 4R, Wedge Brakes. To obtain this publication, refer to the Service Notes page on the front inside cover of this manual.

Identification

Wedge brakes are identified as follows.

- A model number tag is typically attached to the wedge tube or dust shield of the brake assembly.
- An example of a part number format for a 15-inch brake is RSA 1540 1234.

Model Nomenclature

Refer to Figure 7.29 for an explanation of brake model numbers.

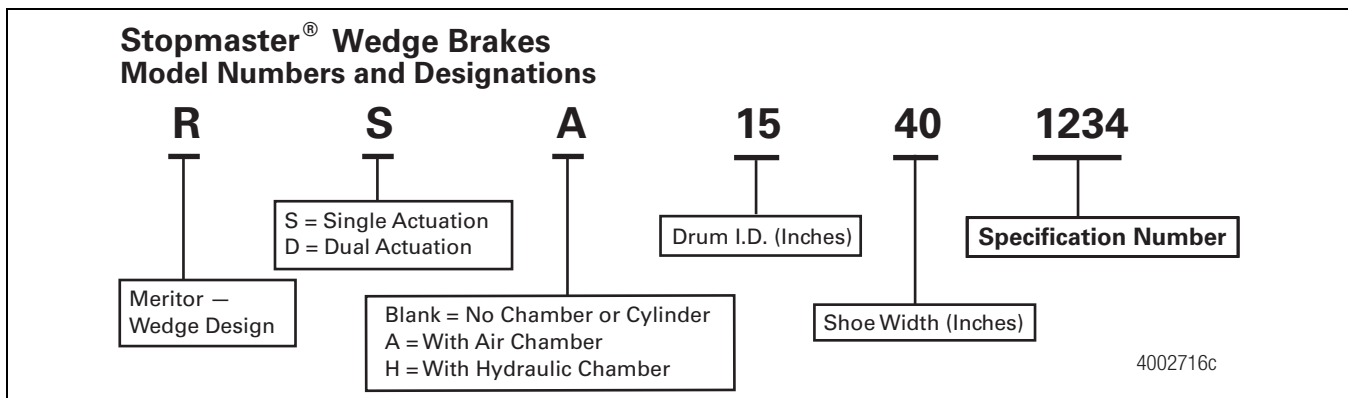

Figure 7.29

Important Information

Meritor automatic brake adjusters (ABAs) should not need to be manually adjusted in service. ABAs should not have to be adjusted to correct excessive pushrod stroke. The excessive stroke may be an indication that a problem exists with the foundation brake, ABA, brake actuator or other system components.

Meritor recommends troubleshooting the problem, replacing suspect components and then confirming proper brake operation prior to returning the vehicle into service.

In the event that a manual adjustment must be made (although not a common practice), a service appointment and full foundation brake, ABA, and other system component inspection should be conducted as soon as possible to ensure integrity of the overall brake system.

For Meritor brake adjustment, refer to the brake adjustment tables in this section. For non-Meritor brake adjusters, refer to the brake manufacturer's service procedures.

Brake Adjustment Procedure

WARNING

You must manually adjust the brake after you perform maintenance or service. Do not depend on the automatic adjusters to remove the excessive clearance created when you back off the brake during service. The automatic adjusters are designed to compensate for normal lining wear. Damage to components and serious personal injury can occur.

Park the vehicle on a level surface. Block the wheels to prevent the vehicle from moving. Support the vehicle with safety stands. Do not work under a vehicle supported only by jacks. Jacks can slip and fall over. Serious personal injury can result.

1. Raise the vehicle so the wheel is off the ground.

WARNING

Before you service a spring chamber, carefully follow the manufacturer's instructions to compress and lock the spring to completely release the brake. Verify that no air pressure remains in the service chamber before you proceed. Sudden release of compressed air can cause serious personal injury and damage to components.

2. If the brake has a spring chamber, cage the spring. Rotate the drum to verify that the brake is completely released.

3. Remove the plugs from the adjustment and inspection slots on the dust shield.
4. While you rotate the drum, use an adjusting spoon to turn the adjusting bolt until the linings drag heavily on the drum. Turn the adjusting bolt 10-20 teeth in the opposite direction until the lining-to-drum clearance is 0.020-0.040-inch (0.51-1.02 mm). Operate the brakes. Use a ruler to measure movement at the center of the shoe to determine the lining-to-drum clearance.
5. Repeat Step 4 for the other adjuster on the brake.
6. If the brake has a spring chamber, release the spring.

NOTE: Meritor KIT 1184 includes an adjusting spoon plus a seal driver and a brake spring tool. The kit or the individual tools are available from Meritor Aftermarket Parts and Services, 7975 Dixie Highway, Florence, KY 41042. Adjusting spoons available from tool manufacturers include Kent-Moore J-34061, Proto 2006 and Snap-on® S-9523.

Inspection Procedure

WARNING

Park the vehicle on a level surface. Block the wheels to prevent the vehicle from moving. Support the vehicle with safety stands. Do not work under a vehicle supported only by jacks. Jacks can slip and fall over. Serious personal injury and damage to components can result.

Every Two Months or 25,000-30,000 Miles (40 000-48 000 km)

Remove the plugs from the inspection holes in the dust cover. Check for lining wear and lining-to-drum clearance. Check for correct operation of the service and parking brake systems as follows.

1. Some linings have a groove in the edge of the lining. Some linings are scalloped at the four inner corners. Figure 7.30. When linings are worn so that the groove or the scallops are not visible, replace the linings.

7 Brakes

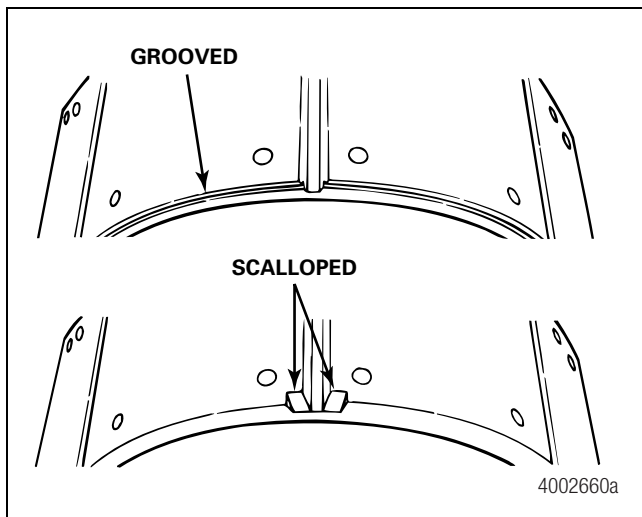

Figure 7.30

- On **RDA** brakes, the linings on both shoes should wear at approximately the same rate. If one shoe wears much faster than the other, correct the problem before you replace the linings. Refer to Troubleshooting in this section.

On **RSA** brakes, it is normal for the leading shoe to wear faster than the trailing shoe. The leading shoe is the first shoe past the plunger housing in the direction of forward wheel rotation. When the plunger housing is behind the axle, the top shoe is the leading shoe. When the plunger housing is in front of the axle, the bottom shoe is the leading shoe. Figure 7.31.

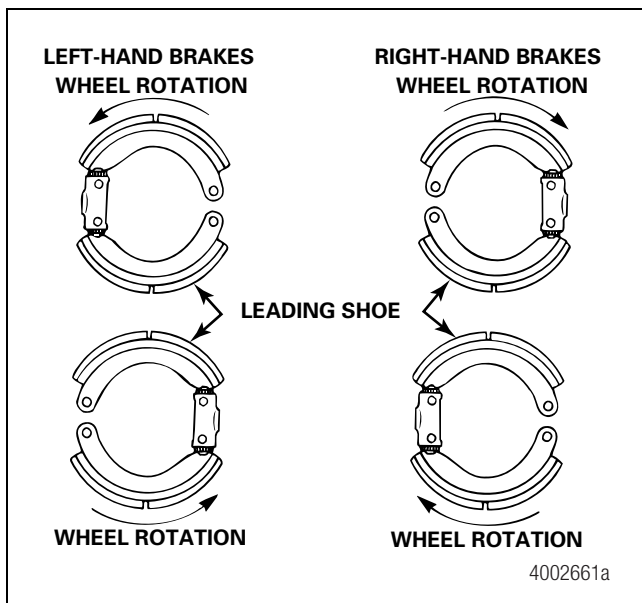

Figure 7.31

- While someone operates the service and parking brake systems, check each brake to verify that it operates correctly. Use a ruler to measure the movement at the center of each shoe to determine the lining-to-drum clearance. Clearance of a shoe must not exceed 0.090-inch (2.3 mm). Total clearance of the two shoes must not exceed 0.120-inch (3.05 mm). When clearance exceeds these limits, the automatic adjusters are not working correctly. Refer to the troubleshooting tables in this section to correct the problem before you adjust the brake.

Lubrication

Lubricate the components shown in Figure 7.32 every 100,000 miles (160 000 km), or once a year, or when any of the following occur.

- The seals are replaced.
- The plungers are removed.
- The brake is relined.
- The grease becomes contaminated or hardened.

Use generous amounts of grease to prevent premature wear. However, do not pack the housing with so much grease that the components cannot move freely.

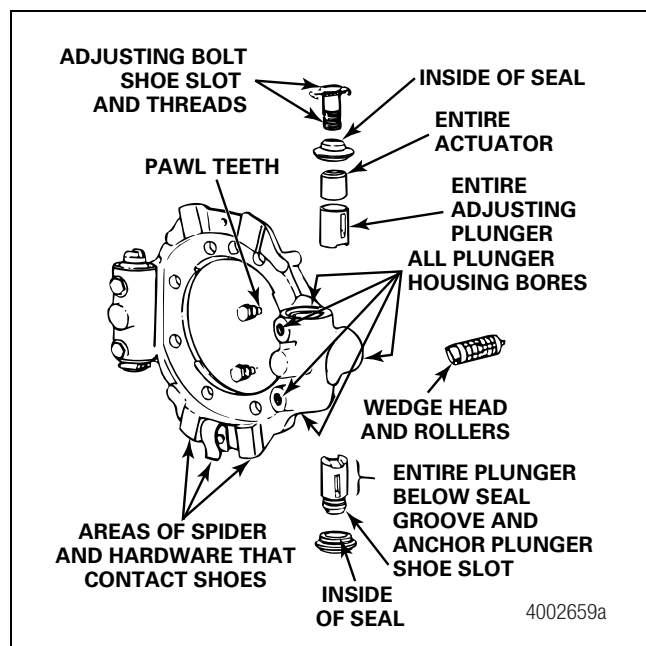

Figure 7.32

Approved Lubricants

Table BQ: Wedge Brake Grease Specifications

| Component | Meritor Specification | NLGI Grade | Grease Description | Outside Temperature |
|---|-----------------------|------------|--------------------------|-----------------------|
| All Actuating Components | 0-616-A | 1 | Clay Base | Down to -40°F (-40°C) |
| All Areas Where Shoes Contact Spider Anchor Plungers Adjusting Bolts or Retainer Hardware | 0-645 | 2 | Synthetic Oil, Clay Base | Down to -65°F (-54°C) |

Important Information

Meritor automatic brake adjusters (ABAs) should not need to be manually adjusted in service. ABAs should not have to be adjusted to correct excessive pushrod stroke. The excessive stroke may be an indication that a problem exists with the foundation brake, ABA, brake actuator or other system components.

Meritor recommends troubleshooting the problem, replacing suspect components and then confirming proper brake operation prior to returning the vehicle into service.

In the event that a manual adjustment must be made (although not a common practice), a service appointment and full foundation brake, ABA, and other system component inspection should be conducted as soon as possible to ensure integrity of the overall brake system.

For Meritor brake adjustment, refer to the brake adjustment tables in this section. For non-Meritor brake adjusters, refer to the brake manufacturer's service procedures.

Wedge Brake Troubleshooting

Diagnostic Charts

Table BR: Wedge Brakes

| Condition | Possible Causes | Correction |
|---|--|--|
| Brakes do not apply. | Plugged or damaged air lines or valves | Repair or replace air lines or valves. |
| | Plungers seized in housing | Inspect the seals, lubricant and plungers. Service as necessary. |
| | Push rod not connected to wedge | Inspect and correct as needed. |
| | Brakes not adjusted correctly | Adjust the brakes correctly. |
| Brakes do not have enough torque during application. | Automatic adjusters not working | Refer to Automatic slack adjusters not working. |
| | Linings worn below minimum thickness, damaged or missing | Replace the linings. |
| | Incorrect lining friction rating | Replace with the correct lining. |
| | Air or spring chamber not threaded completely into plunger housing | Install the chamber correctly. |
| | Plungers seized in housing | Inspect the seals, lubricant and plungers. Service as necessary. |
| | Grease or oil on the linings | Clean or replace the linings. Check the wheel seals for leaks. |
| | Damaged diaphragm in the air chamber | Repair or replace the air chamber. |
| | Leaks in the air system | Repair the leaks. |
| | Worn components | Replace the components. |

7 Brakes

Table BR: Wedge Brakes

| Condition | Possible Causes | Correction |
|--|---|--|
| One shoe lining wears faster than the other, RDA models only. | Wedge not correctly installed in air chamber | Install the wedge and air chamber correctly. |
| | Brake shoes installed backward | Install the shoes correctly. |
| | Weak or damaged shoe return springs | Replace the return springs. |
| | Wedge and roller assembly not correctly installed in plunger ramp | Install correctly. |
| | Lining friction ratings do not match | Use the matched linings. |
| | One wedge roller is out of the cage | Repair or replace the wedge assembly. |
| | Grease or dirt on linings | Clean or replace the linings. Check the wheel seal for leaks. |
| | Loose, worn or missing shoe retaining hardware | Repair or replace the retaining hardware. |
| | Lightweight or out-of-round drums | Replace the drums. |
| | Automatic slack adjuster not operating correctly | Refer to Automatic slack adjusters not working. |
| | Brakes are dragging | Refer to Brakes drag. |
| | Unequal pressure in air chambers | Determine the cause and repair or replace as needed. |
| | Loose wheel bearings | Adjust the wheel bearings correctly. |
| Brakes grab or vibrate during application | Low air pressure at air chamber | Inspect and repair the air delivery system. |
| | Grease or dirt on linings | Clean or replace the linings. Check the wheel seals for leaks. |
| | Wedge and roller assembly not correctly installed in plunger ramp | Install correctly. |
| | Incorrect lining friction rating | Replace with the correct lining. |
| | Linings worn below minimum thickness, damaged or missing | Replace the linings. |
| | Shoes bind due to incorrect assembly or weak, worn out shoes | Install the shoes correctly or replace as needed. |
| | Weak or damaged shoe return springs | Replace the return springs. |
| | Spring brake not completely released | Inspect and repair the air system and spring chamber. |
| | Weak or damaged return springs | Replace the return springs. |
| | Air lines connected to incorrect ports | Connect the air lines correctly. |
| Brakes drag | Leaks in the air system | Repair the leaks. |
| | Air trapped in air chamber when brakes are released | Repair or replace the release valves. |
| | Brake drum out-of-round | Replace the drum. |
| | Loose wheel bearings | Adjust the wheel bearings correctly. |
| | Push rod not connected to wedge | Inspect and correct as needed. |
| | Plungers seized in housing | Inspect seals, lubricant and plungers. Service as necessary. |
| | Damaged return spring or cotter pin on wedge assembly | Replace the spring or cotter pin. |
| | Grease or dirt on linings | Clean or replace the linings. Check the wheel seals for leaks. |
| | Loose, worn or missing shoe retaining hardware | Repair or replace the retaining hardware. |
| | Incorrect manual adjustment | Adjust the brake correctly. |

Table BR: Wedge Brakes

| Condition | Possible Causes | Correction | |
|---|---|---|---|
| Automatic brake adjusters not working | Damaged shoe retainer or detent clip on the adjusting bolt head | Replace the adjusting bolt. | |
| | Adjusting bolt threads extend through bottom of actuator | Install the adjusting bolt so the threads do not extend past the bottom of the actuator. | |
| | Adjusting bolt threaded too tightly | Verify that the bolt turns freely. | |
| | Brake shoes installed backward | Install the brake shoes correctly. | |
| | Foreign material on threads of adjusting bolt or actuator | Clean or replace the adjusting bolt and actuator. Replace the seals as needed. | |
| | Lack of lubrication, contamination, corrosion, damaged seals | Replace the adjuster parts and seals as needed. Lubricate at the scheduled intervals. | |
| | Damaged teeth on pawl or actuator | Replace the pawl and plunger assembly. | |
| | Damaged pawl spring | Replace the pawl assembly. | |
| | Weak or damaged shoe return springs | Replace the return springs. | |
| | Pawl seized in its bore | Clean and replace the pawl or housing as needed. | |
| | Anchor plungers installed in the incorrect locations | Install the plungers in the correct locations. | |
| | Spring brake does not hold | Broken power spring. | Repair or replace assembly as described by the manufacturer. |
| | | Power spring unable to expand completely, spring still caged | Determine the cause and repair or replace as described by the manufacturer. |
| Hold-off air not being exhausted | | Determine the cause and repair or replace as described by the manufacturer. | |
| Air chamber assembly not threaded completely into the plunger housing | | Correctly thread the air chamber into the housing. Tighten the collet nut to prevent loosening. | |
| Brakes not adjusted correctly | | Adjust the brakes correctly. | |
| | Grease or dirt on the linings | Clean or replace the linings. Check the wheel seals for leaks. | |

7 Brakes

Four-Piston Quadraulic Disc Brakes

Technical Publications

How to Obtain Additional Maintenance and Service Information

Refer to the publications in Table BS. To obtain these publications, refer to the Service Notes page on the front inside cover of this manual.

Table BS: Publications

| Model | Manual |
|---|-----------------------------|
| Four-Piston Quadraulic Disc Brake Caliper | Maintenance Manual MM-2075 |
| Wheel Equipment (Disc Wheel Hubs and Brake Drum Failure Analysis) | Maintenance Manual MM-99100 |

Description

Meritor's quadraulic disc brakes have a four-piston, fixed-mount caliper design for use on both front and rear drive axes. An installation includes four major components — the caliper assembly, support assembly, hub/rotor assembly and the attaching hardware.

The inboard pistons apply the inboard pads and the outboard pistons apply the outboard pads. Two sizes of calipers are used, 2.520-inch (64 mm) and 2.756-inch (70 mm).

Features of the caliper include the following.

- Designed for hydraulic brake systems
- Hard-mounted to the anchor plate to eliminate caliper and anchor plate replacement
- Designed with hardened stainless steel mounting surfaces, high temperature piston boot compound, sealed bleeder screws and full-coverage zinc plating
- Compatible with anti-lock braking systems (ABS) and existing hydraulic systems
- Helps to increase lining life
- Can be adapted to fit most vehicles with a hydraulic system that supplies to 1,800 psi (12 402 kPa)
- Available in 33,000 lbs maximum GVWR (4 x 70 mm) and maximum 24,000 lbs GVWR (4 x 64 mm). brake pads, two stainless steel lining rail covers installed with button head bolts, a pad retainer spring and bolt, bleeder screw and crossover tube

Identification

An assembly number is located on the side of the four-piston Quadraulic™ disc brake caliper. Figure 7.33.

The previous and current-style four-piston Quadraulic™ disc brake calipers are shown in Figure 7.34.

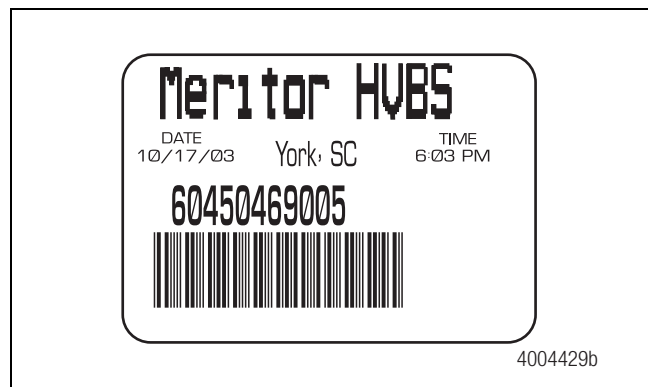

Figure 7.33

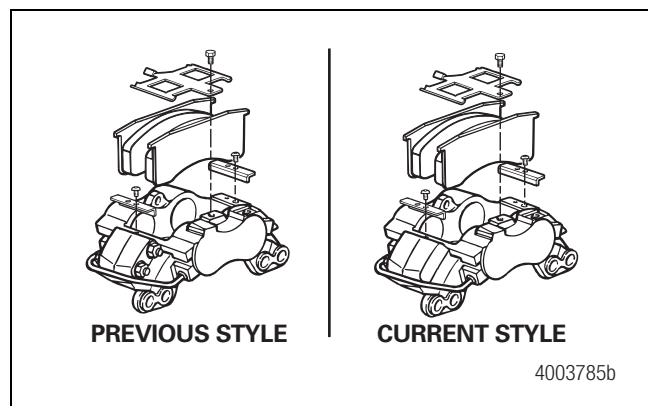

Figure 7.34

Current Style

Metric caliper bolts

Caliper housing halves held together by bolts in blind holes in the bridge area.

Integral piston/heat shield

Phenolic piston

Previous Style

SAE caliper bolts

Caliper housing halves held together by bolts and nuts in the bridge area.

Separate piston and heat shield

Metal piston

Four-Piston Quadraulic Disc Brake Inspection

Caliper

1. Clean the area around the brake hose. Use brake parts cleaner.
2. Inspect the heat shields (previous style only) for wear and damage. Replace worn or damaged shields.
3. Inspect the caliper lining spacers for wear and damage. Replace worn or damaged spacers.
4. Inspect the housing for cracks or damage. Replace a cracked or damaged housing.

NOTE: The outside diameter of the piston is the calipers primary sealing surface and is manufactured to very close tolerances. Replace a piston if the outside diameter is damaged. Do not refinish or use abrasives, including an emery cloth, on the piston. Damage to components can result.

5. Inspect the outside diameter of the pistons for scoring, nicks, corrosion, wear and damage.
 - **If any of these conditions are evident:** Replace the pistons. Do not refinish or use abrasives.
6. Inspect the caliper bore for scoring, nicks, corrosion, wear and damage.
 - **If any of these conditions are evident:** Replace the caliper.

CAUTION

Use a crocus cloth to remove minor stains and corrosion from the caliper bore. Do not use abrasives, including an every cloth. If you cannot remove minor stains and corrosion, replace the caliper bore to avoid damage to components.

7. Inspect the caliper bore for minor stains and corrosion.
 - **If these conditions are evident:** Use a crocus cloth to remove stains or corrosion. Clean the caliper bore after using a crocus cloth. Do not use abrasives, including an emery cloth.
 - **If you cannot remove stains and corrosion from the caliper bore:** Replace the caliper.



Caliper Mounting Plate

1. Inspect caliper mounting plate area for rust, corrosion. Replace a damaged or worn mounting plate.

2. Use a wire brush to clean the caliper mounting area.
3. Inspect the mounting plate for cracks or elongated bolt holes.
 - **If these conditions are evident:** Replace the mounting plate.

Bleeding the Brake System

Refer to the manufacturer's service information for ABS bleeding instructions.

1. Check the master cylinder reservoir and fill, if necessary, with DOT 3 or DOT 4 brake fluid.
2. Bleed the brakes in the following order: right rear, left rear, right front and left front.
3. Each four-piston caliper is equipped with two bleeder screws. Loosen the inner bleeder screw, which is always on the top and purge the air. Tighten it loosely.
4. Open the outer bleeder screw and purge the air and tighten the bleeder screw to 9-12 lb-ft (1.2-16.3 N•m). 
5. Now again open the inner bleeder screw and purge the air and tighten the bleeder screw to 9-12 lb-ft (12.2-16.3 N•m). 
6. Repeat this procedure for all other brakes in the sequence specified in Step 2.
7. Test the brakes prior to returning the vehicle to service. A firm pedal should be felt during brake application.

7 Brakes

Four-Piston Quadraulic Disc Brake Troubleshooting

Diagnostic Charts

Table BT: Four-Piston Quadraulic Disc Brakes

| Conditions | Possible Causes | Correction |
|--|--|---|
| Excessive pedal effort | Pads worn below minimum thickness | Install the new pads. |
| | Faded, overheated condition, glazed pads, blued or heat-checked rotors | Replace the rotor or reface the pads if sufficient lining remains. |
| | Grease, oil or brake fluid on linings | Install the new pads in axle sets. |
| | Seized or frozen pistons | Disassemble the calipers and free the pistons, or replace the caliper. |
| Pedal pulsation, brake roughness or chatter | Excessive lateral runout of brake rotor | Check with a dial indicator. Install a new rotor if runout exceeds the maximum specified. |
| | Excessive out-of-parallelism of brake rotor | Check the parallelism, rotor thickness variation, with a micrometer and resurface the rotor, or install a new rotor if the parallelism exceeds the maximum allowed. |
| | Loose or worn steering or suspension parts | Replace the parts and realign. |
| | Excessive front bearing clearance | Readjust the bearing to specification. |
| Vehicle pulls to one side | Brake fluid, oil or grease on linings | Install the new pads in axle sets. |
| | Unmatched linings, uneven lining wear, distorted pads | Install the new pads in axle sets. |
| | Rough rotor surfaces on one rotor | Resurface or replace the rotor in axle sets. |
| | Seized or frozen pistons | Disassemble the caliper and repair or replace. |
| | Loose caliper mounting bolts | Tighten to specifications. |
| | Uneven tire pressure, tread wear or size, right to left | Equalize to the recommended pressures. Install the correct size tires with good tread. |
| | Excessive rotor parallelism or runout | Resurface or replace the rotor. |
| | Restricted hose or line | Examine the hoses and lines and replace as necessary. |
| | Front end out of alignment | Reset the alignment. |
| | Leaky caliper | Cylinder bore surface scored or corroded |
| Caliper piston seal damaged or worn | | Disassemble the calipers and install the new seals and boots. |
| Caliper piston damaged | | Replace the piston. |

Table BT: Four-Piston Quadraulic Disc Brakes

| Conditions | Possible Causes | Correction |
|--|---|--|
| No braking effect or excessive pedal travel | Reservoir fluid level low | Check for causes of fluid leak, repair as required and refill the reservoir. Bleed the system as needed. |
| | Air in the hydraulic system | Bleed the system. |
| | Bleeder screw loose or open | Bleed the system and tighten the bleeder screw. |
| | Caliper piston seal damaged | Disassemble the caliper and replace the piston seals. Replace the piston if damaged. |
| | Excessive rotor runout or bent rotor | Check the rotor with a dial indicator. Install a new rotor if the runout exceeds the maximum specified. |
| | Bad or excessively loose wheel bearings | Adjust or replace the bearings as needed. |
| | Poor quality brake fluid | Drain and clean the system. Replace with the recommended brake fluid. |
| Brake noise — chatter | Weak brake hose that expands under pressure | Replace the hoses as necessary. |
| | Excessive lateral runout of rotor | Check the runout with a dial indicator. Install a new rotor if the runout exceeds the maximum specified. |
| | Lack of rotor parallelism | Check the parallelism with a micrometer. Resurface or install a new rotor as required. |
| Brake noise — scraping | Loose wheel bearing | Readjust the bearing to the specified torque. |
| | Rust or mud build-up on edges of rotor and on caliper housing | Clean or replace as necessary. |
| | Worn pad or pad installed backward | Replace the pads in axle sets only with the friction surface against the rotor. |
| Brake noise — groan | Incorrect caliper alignment permitting rotor to scrape on housing | Correct the alignment. |
| | Pressure on the brake pedal too light | Slightly increase the pedal effort to eliminate noise. |
| Brake noise — rattle | Excessive clearance between the shoe and caliper | Install the new pads. |
| | Pad retainer spring missing or not correctly positioned | Install a new pad retainer spring or position correctly. |
| Brake noise — squeal | Glazed pads | Resurface or replace the pads in axle sets only. |
| | Weak pad retainer spring | Install a new pad retainer spring. |
| | Pad wear indicator contacting rotor | Install the new pads in axle sets only. |
| | Foreign material embedded in linings | Replace the pads in axle sets only. |

7 Brakes

DuraPark® Hydraulic Drum Brakes

Technical Publications

How to Obtain Additional Maintenance and Service Information

Refer to Maintenance Manual MM-99101, DuraPark® Type A2LS Heavy-Duty Drum Brake Assembly. To obtain this publication, refer to the Service Notes page on the front inside cover of this manual.

Description

The DuraPark® rear hydraulic drum brake consists of a backing plate, two brake shoe and lining assemblies, an adjuster cylinder and park cylinder. The adjuster cylinder acts as a conventional wheel cylinder and contains automatic adjusters which maintain a shoe-to-drum clearance within a specified range. The park cylinder acts as a conventional wheel cylinder and also acts to apply and release the shoes for parking. Figure 7.35.

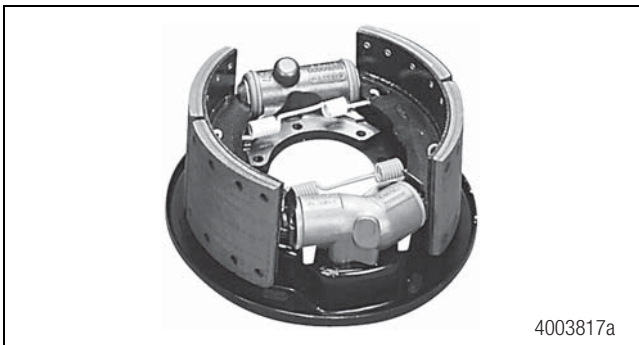

4003817a

Figure 7.35

DuraPark® Hydraulic Brake Product Update

DuraPark® hydraulic brake changes are visible and can be seen during various maintenance procedures. Figure 7.36, Figure 7.37, Figure 7.38, Figure 7.39, Figure 7.40 and Figure 7.41.

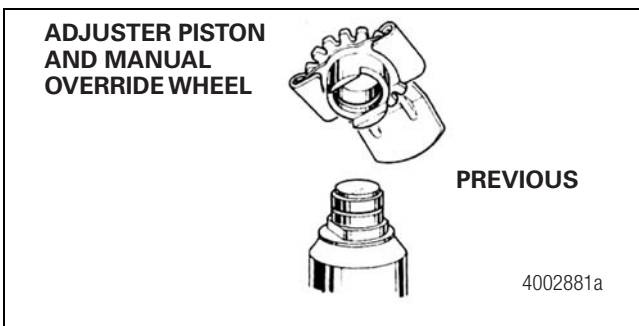

4002881a

Figure 7.36

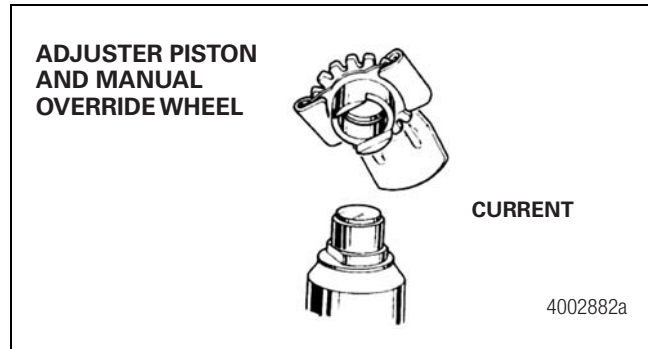

4002882a

Figure 7.37

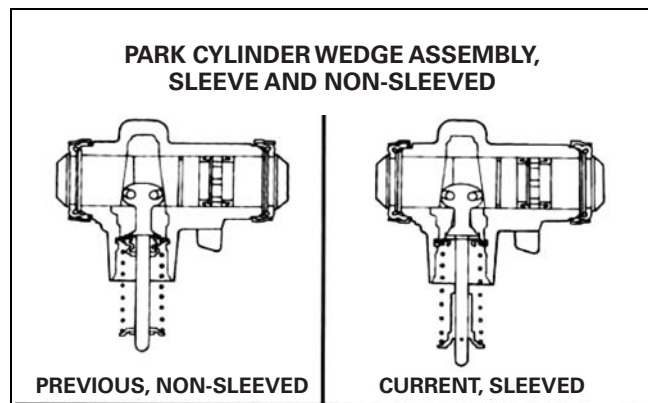

Description of Service Parts:

- 1) Sleeved **Park Cylinders** now supersede non-sleeved cylinders.
- 2) Sleeved **Wedge Kits** now supersede non-sleeved kits.

IMPORTANT INSTALLATION NOTE: Check the **BRAKE CHAMBER** design level shown below, whenever you change a **PARK CYLINDER** or **WEDGE KIT**. The original brake chamber (pre-November 1985, shown below) is without an O-ring seal on the inside of the jam nut. These chambers are identified by the slots in the base of the jam nut. The new chamber design (after November 1985, shown below) has an O-ring seal inside of the jam nut. The new chamber is without slots in the jam nut.

If the brake chamber is the original design (with slots) and is being used with a **SLEEVED** wedge assembly, the jam nut threads **MUST** be sealed 360 degrees around with Permatex® FORM-A-GASKET No. 2 as shown below. This sealing will prevent the ingress of moisture into the park cylinder.

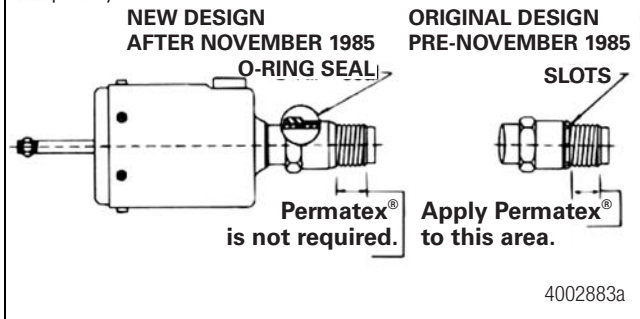

4002883a

Figure 7.38

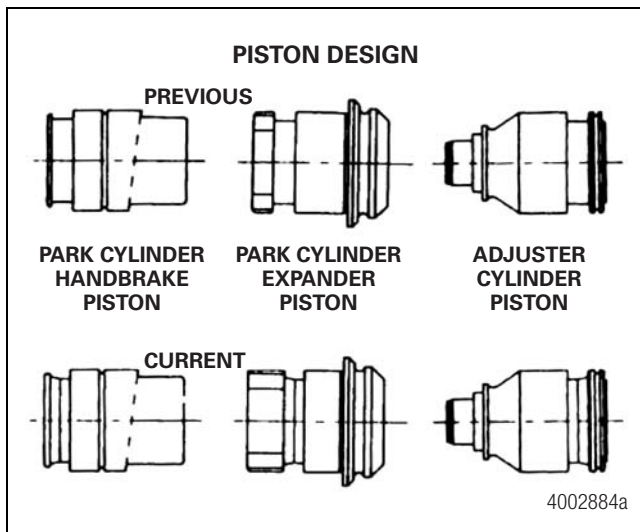

Figure 7.39

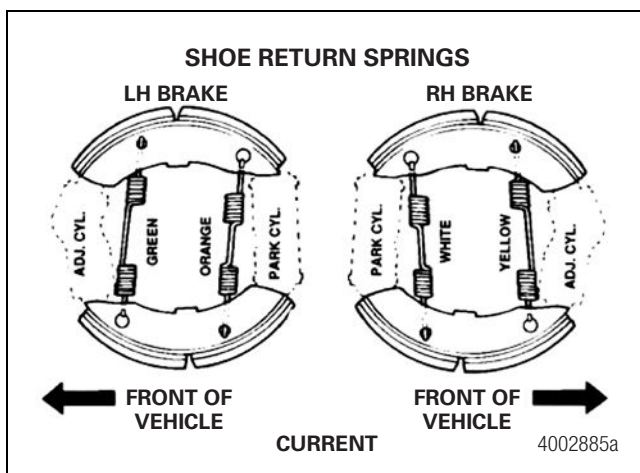

Figure 7.40

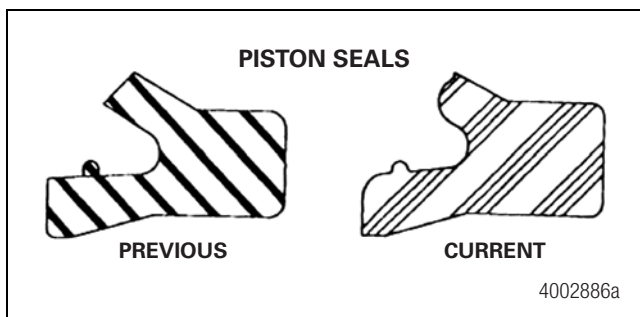

Figure 7.41

Adjustment Procedures

Measuring Shoe-to-Drum Clearance

NOTE: The clearance between the drum and lining may vary from top to bottom and from left to right sides of the vehicle. This is normal and does not indicate that service is required. In the past design, the top shoe clearance was adjusted during reverse stops, and the bottom shoe clearance was adjusted during forward stops. However, with the newer design shoe return springs, both top and bottom shoes are allowed to adjust during stops in either direction.

NOTE: Correct and full adjustment will only occur with the drum rotating. Pumping the brake pedal with the vehicle stationary will not achieve correct adjustment.

1. Block the front wheels to prevent the vehicle from moving before any service work is started.
2. Manually cage the parking brake chambers per the vehicle manufacturer's recommendations.
3. Center the shoes in the drum by making two slow, hard applications and releases of the service brakes.
4. Remove the plugs from the lining inspection holes. Insert feeler gauges between the lining and the drum approximately half way across the width of the lining. The feeler gauges must be on the lining surfaces and not in the area between the two linings blocks.

The normal shoe-to-drum clearance range is 0.020-0.050-inch (0.508-1.27 mm). In some circumstances, larger clearances may be seen. In these cases, it is necessary to add the top shoe clearance and the bottom shoe clearance. The normal sum of the top and bottom shoe clearance is 0.040-0.100-inch (1.016-2.54 mm). Do not attempt to adjust the clearances if they meet either of the above requirements. Figure 7.42 and Figure 7.43.

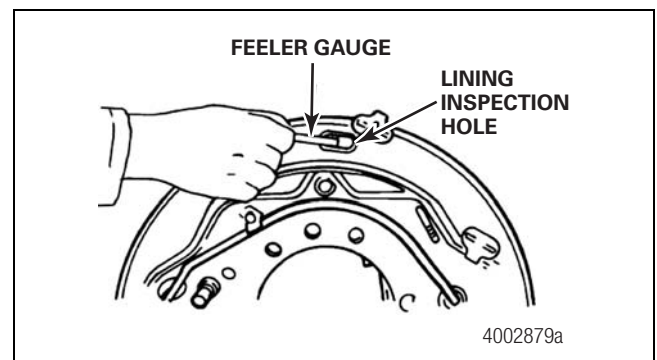

Figure 7.42

7 Brakes

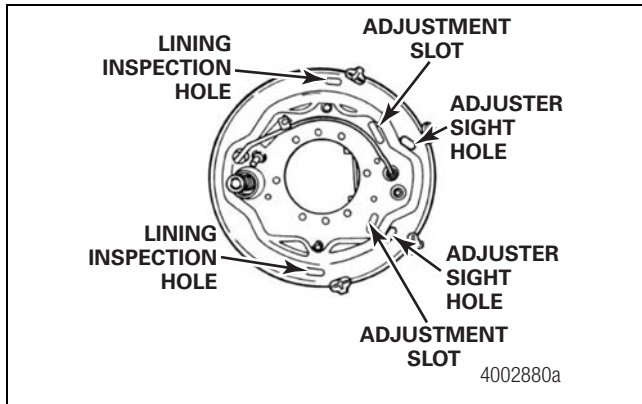

Figure 7.43

Manual Brake Adjustment

1. Block the front wheels to prevent the vehicle from moving before any service is started.
2. Release the parking brake system via a button, lever or switch in the cab. This action pressurizes the spring chamber and compresses the parking brake spring.
3. Cage the parking brake spring in accordance with your vehicle or spring chamber manufacturer's recommendations.
4. Jack up the rear wheels and install safety stands.
5. Center the shoes in the drum by making two slow, hard applications and release of the service brakes.
6. Manually adjust the shoes by pushing or pulling the adjusting tool (OTC part number D90T-2588-AR) in the direction shown. Adjust worn shoes to 0.020-inch (0.508 mm). Adjust new shoes to 0.030-inch (0.762 mm).
7. Run the engine to ensure that the park brake system is pressurized. The cab mounted park brake button, lever or switch should still be in the released position.
8. Uncage the park brake spring in accordance with your vehicle or spring chamber manufacturer's recommended procedure.
9. Rotate each wheel by hand to ensure that the hydraulic system has fully released the park brakes.
10. Apply the park brake and check that the wheels cannot be rotated by hand.
11. Remove the safety stands and blocks.
12. Run the engine and release the park brake.
13. Drive the vehicle slowly while checking the service and park brakes.

NOTE: Extra caution should be taken if linings have not yet been burnished.

14. Road test.

Brake Drums and Rotors

Technical Publications

How to Obtain Additional Maintenance and Service Information

Refer to the publications in Table BU. To obtain these publications, refer to the Service Notes page on the front inside cover of this manual.

Table BU: Publications

| Model | Manual |
|---|-----------------------------|
| Wheel Equipment (Disc Wheel Hubs and Brake Drum Failure Analysis) | Maintenance Manual MM-99100 |
| Parts Failure Analysis | Manual TP-87123 |

Brake Drum Inspection and Failure Analysis

Warnings appear before maintenance procedures to alert you to stud and nut conditions that can affect your safety and the integrity of the vehicle and its components.

Carefully read all of the warnings before you perform the procedures.

The Brake Drum section provides information on brake drum wear conditions, conditions that can affect brake drum wear, a troubleshooting table, maintenance procedures, replacing a brake drum and preventive maintenance tips.

This information is also available in VHS format. To obtain a copy of the video, Brake Drum Failure Analysis, call ArvinMeritor's Customer Service Center at 800-535-5560 and request item number T99105V.

Fasteners Used on a New Brake Drum Assembly for Shipping

An original equipment manufacturer will use one of the methods listed below to secure a new outboard brake drum assembly during shipping.

- Two hexagon nuts secure the assembly. Discard these nuts at removal. Do not use these nuts to attach disc wheels to the hub and drum assembly.
- Two ball seat or two flange nuts, depending on the disc wheel system, secure the assembly. After you remove these nuts, use them with the additional nuts required for the system.
- Eight or 10 ball seat or flange nuts, depending on the disc wheel system, secure the assembly. After you remove these nuts, use them to attach the disc wheels to the hub and drum assembly.

Brake Drum Wear Inspection

Inspect brake drums when you perform maintenance and service procedures. Refer to the brake drum wear conditions in this section to identify the types, possible causes and corrective actions for brake drum wear.

1. Closely check wear patterns on the friction surface inside the drum.
2. The maximum allowable brake drum diameter is stamped or cast into the outer edge of the drum. Place a brake drum diameter gauge inside the drum. Take several measurements within 90 degrees of each other at the open and closed edges of the drum's friction surface.
 - **If any of these measurements are 0.120-inch (3.048 mm) over nominal diameter:** Replace the brake drum. Figure 7.44.
 - **If a brake drum is out-of-round:** Replace the drum.

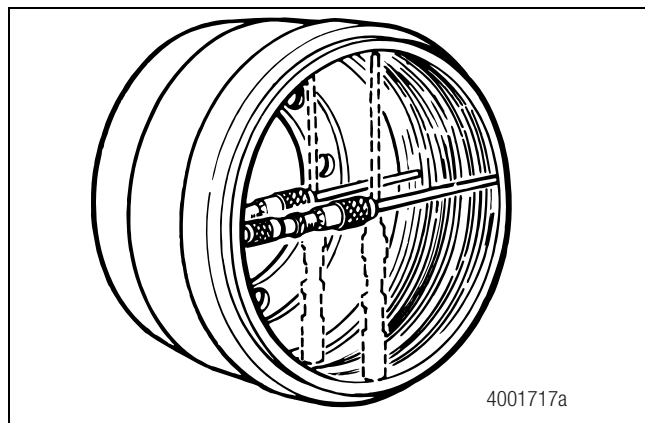

Figure 7.44

Table BV

| Nominal Diameter | Discard Drum at |
|------------------|-----------------|
| 16.5" | 16.620" |
| 15" | 15.120" |

3. Check that the brake drum surface is concentric to the bearings within 0.015-inch (0.381 mm) total indicator runout (TIR). Excessive end play can result when the drum's surface is not concentric to the bearings, which can result in deep drum wear on one side only.
4. Inspect all components for corrosion before assembly, especially the brake drum pilot and mating hub and bolt flanges. Corroded parts can cause excessive end play, which can result in deep drum wear on one side only.

Clean the Mounting Surfaces

⚠ WARNING

Before you perform assembly procedures, thoroughly clean the mounting surfaces to remove paint and contaminants, which can loosen fasteners and cause the wheels to separate from the vehicle. Serious personal injury and damage to components can result.

1. Always thoroughly clean the hub mounting surfaces where the outboard brake drum mounts.
2. Always thoroughly clean the brake drum's outboard flange, which is the mounting surface for the disc wheels.
3. Remove dirt and contaminants from mounting surfaces before you perform the assembly procedures. Do not apply paint to the mounting surfaces, studs or nuts. Paint decreases a fastener assembly's capability to maintain clamp load.
4. If the assembly has an inboard-mounted brake drum, clean the hub flange areas where the disc wheels mount.
5. If the entire assembly is off the axle spindle and you will replace the brake drum, clean the hub mounting surfaces where the brake drum mounts.

7 Brakes

⚠ WARNING

Replace a worn or damaged hub assembly or disc(s), which can cause excessive runout. A wheel(s) can separate from the vehicle. Serious personal injury and damage to components can result.

6. Check the following areas for wear, which can be caused by a wheel that runs loose on the hub.
 - The pilot on a hub-piloted assembly
 - The mounting surfaces of all hub types
 - Outboard drum mounting surfaces

NOTE: Use a calibrated torque wrench with right- and left-hand capabilities to tighten the ball seat mounts.

7. Ensure that the fasteners are tightened in the correct tightening sequence and to the correct torque specifications. Use a torque wrench to tighten the fasteners. Figure 7.45.

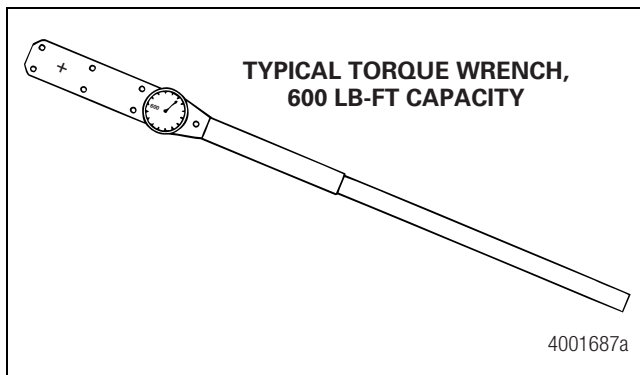

Figure 7.45

8. If wheels have run loose on the hub, the pilot on hub-piloted assemblies and the mounting faces of all types of hubs, or outboard brake drum mounting faces, will show wear.
 - A. Replace the entire hub assembly, including the nuts. A worn pilot or brake drum mounting surface will cause fatigue damage to the studs, and the hub or outboard brake drum mounting surface will not provide a flat support for the disc wheels.
 - B. Replace the disc wheels.

Brake Drum Procedures

How to Clean a Brake Drum

NOTE: Use a wet cleaning method to prevent fibers from the friction material from becoming airborne.

Use the following procedure to clean the drums during maintenance and service, and after machining.

1. Clean the brake drum with a cloth dampened with water or a water-base solution.
2. If a drum has been exposed to leaking oil or grease, perform Step 1. Then clean the drum with a non-oil base solvent.

Replace a Brake Drum

⚠ WARNING

Park the vehicle on a level surface. Block the wheels to prevent the vehicle from moving. Support the vehicle with safety stands. Do not work under a vehicle supported only by jacks. Jacks can slip and fall over. Serious personal injury and damage to components can result.

Before you service a spring chamber, carefully follow the manufacturer's instructions to compress and lock the spring to completely release the brake. Verify that no air pressure remains in the service chamber before you proceed. Sudden release of compressed air can cause serious personal injury and damage to components.

1. Park the vehicle on a level surface. Block the wheels.
2. Raise the vehicle. Support the vehicle with jackstands.

NOTE: Before you remove the wheel and brake drum, it may be necessary to de-adjust the slack adjuster to provide clearance between the brake linings and drum.

3. Remove the wheel lug nuts. Remove the wheel assembly.
4. Loosen the drum from the hub mounting bolts. Remove the drum.
 - **If the drum is rusted or corroded:** Treat the bolts. Apply pressure to one side of the drum. Pull the drum from the hub.
5. Clean the brake drum surfaces to remove dirt and contaminants.

6. Measure the replacement drum in several places to ensure that dimensions are correct.
7. Clean the debris from the drum.

NOTE: At installation, take care that wheel bearing grease does not contaminate the drum.

8. Clean the drum and hub pilots with a wire brush.
9. Align the drum with the hub bolts. Install the drum onto the hub. Ensure that the drum seats flat against the face of the hub.
10. Install the locknuts onto the bolts. Tighten to the correct torque specification. Refer to Table BW.

Table BW: Torque Specifications

| Drum Locknut Sizes | Torque |
|----------------------------|---------------------------------|
| Drum Replacements: | |
| 5/8" diameter | 95-130 lb-ft (129.2-176.8 N•m) |
| 3/4" diameter | 200-250 lb-ft (272-340 N•m) |
| Blind Tapped Holes: | |
| 5/8" diameter | 153-207 lb-ft (208.1-281.5 N•m) |
| 3/4" diameter | 273-367 lb-ft (371.3-499.1 N•m) |

Preventive Maintenance Tips

- Use heavier brake drums to ensure braking capacity. Specify X-10 drums to avoid various types of hot spotting.
- Use 20 psi or greater snubs to break in new linings, rather than light dragging stops.
- Ensure that the brake drum surface is concentric to the bearings within 0.015-inch (0.381 mm) total indicator runout (TIR).
- Thoroughly clean all parts prior to assembly, especially the drum and hub pilots, and the mating hub and bolt flanges. Because these parts fit closely together, dirt, rust or paint can cause runout, which can shorten drum and lining life.
- Discard a brake drum with heat checks of one to two-inches or more on the surface.
- Use component equipment manufacturer-approved replacement linings. Vehicles are usually certified to pass FMVSS 121 original equipment only.

Brake Drum Wear Conditions

Most of the following wear conditions that affect a brake drum require that you replace the drum. Refer to the brake drum diagnostic charts in this section for possible causes of, and corrective actions for, the following wear conditions.

What is Normal Wear?

Brake drums wear evenly under normal operating conditions. Use fleet history, if available, to determine the approximate wear rate of tractor drums. Normal wear is the most common reason to remove a brake drum from service.

What is Deep or Excessive Wear?

It is important to inspect a brake drum for the following excessive wear conditions, which require you to replace the drum.

Deep, Uniform Wear

Deep, uniform wear at the edge of the drum where the lining rub path starts can result from brake drag, brake imbalance and dirt embedded in the brake lining. Figure 7.46 and Figure 7.47.

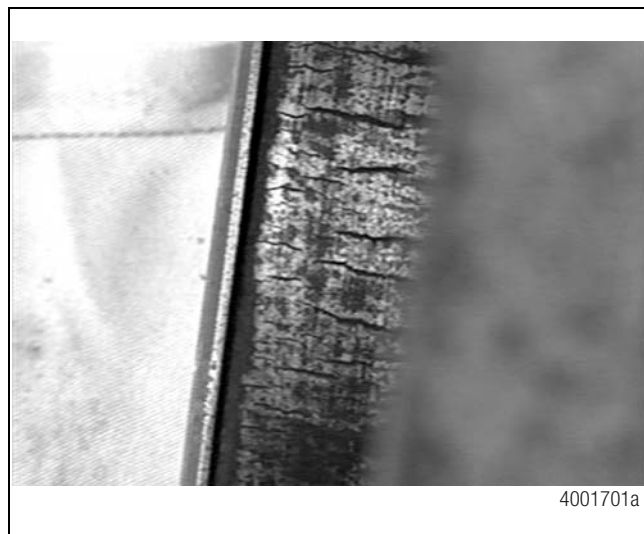

Figure 7.46

7 Brakes

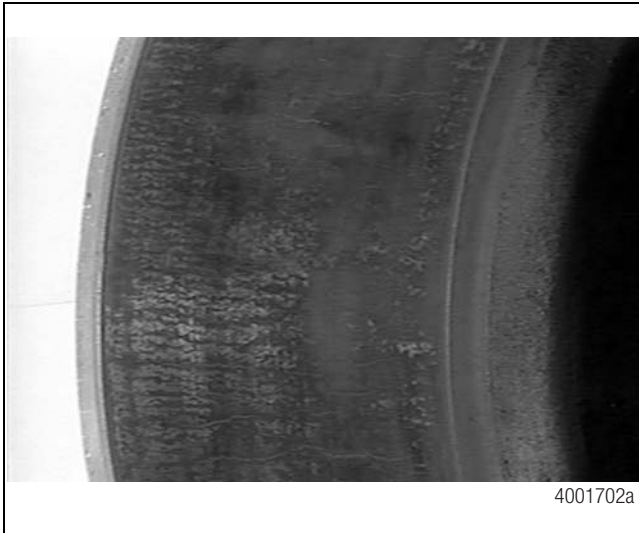

Figure 7.47

Deep Wear on One Side of the Drum Only

Deep wear only on one side of the drum indicates that the drum is not concentric with the bearing center line of the hub. No evidence of hot spotting may be evident. Figure 7.48.

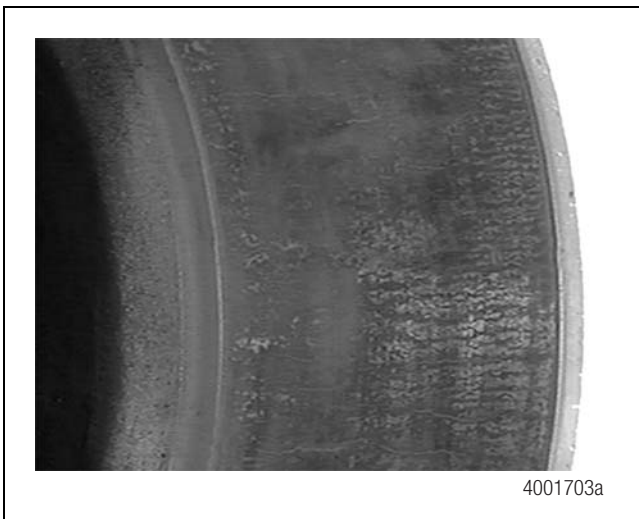

Figure 7.48

Uniform Heat Checking

Heat checking is fine cracks on the drum's surface. This is a normal condition that results from continuous heating and cooling of the friction surface. Cracks that are one to two-inches or more are usually deep and require that you replace the drum. Figure 7.49.



Figure 7.49

Heat Checking Only on One Side of the Drum

Heat checking that appears only on one side of the drum results when a drum is not concentric to the linings. Hot spotting may or may not be evident. However, you may also notice deep wear on the same side of the drum. Replace the drum. Figure 7.50.

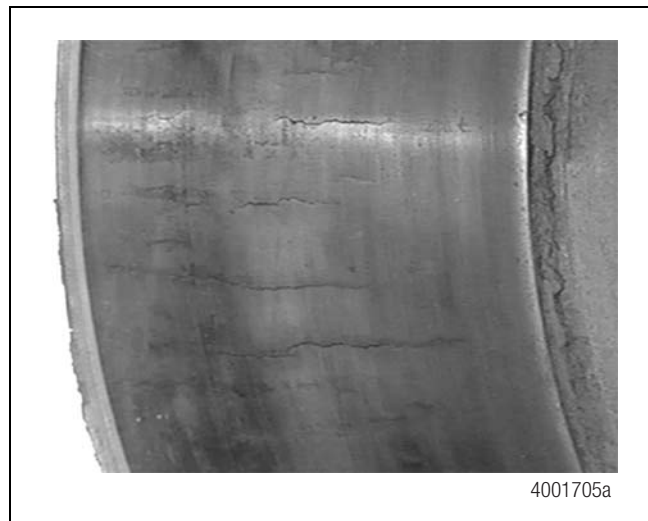

Figure 7.50

Hot Spotting (Black Spots)

Hot spotting is black spots on a drum's surface that can appear in the following ways.

Over the Entire Surface (Uniform). Figure 7.51.

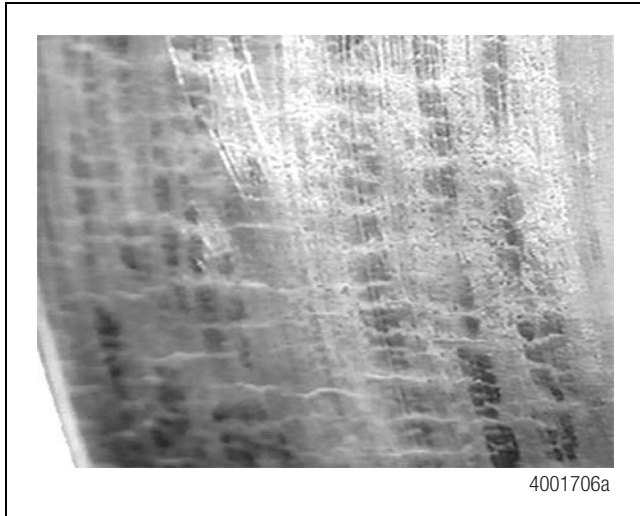

Figure 7.51

On One Side Only. Figure 7.52.

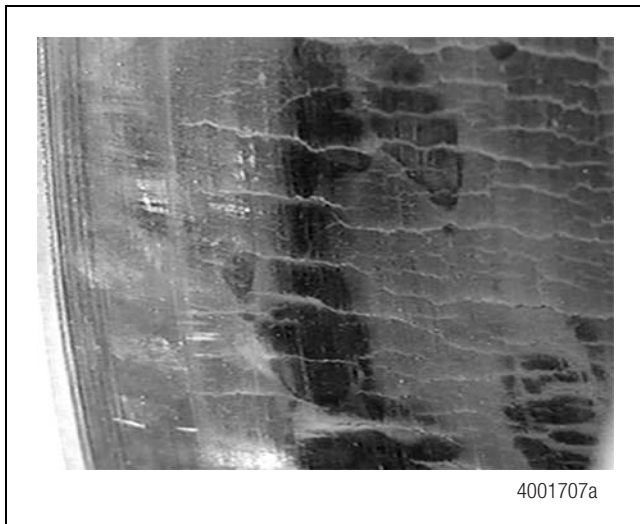

Figure 7.52

In Three Equally Distant Places. Figure 7.53.

Replace the brake drum.

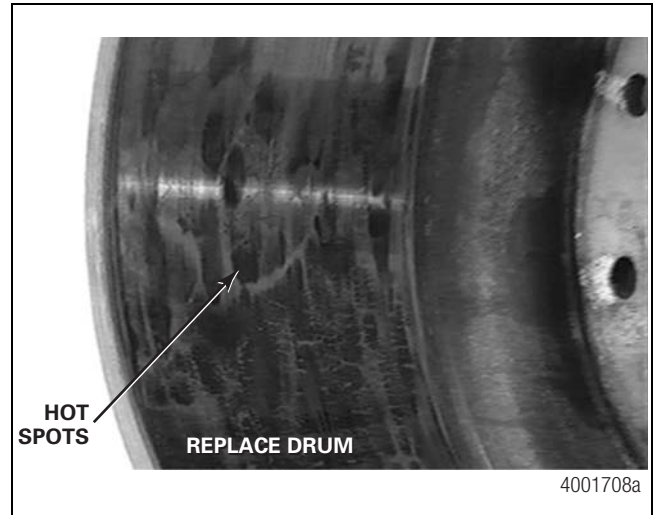

Figure 7.53

Polished or Glazed Drum

A polished or glazed drum has a mirror-like finish on the friction surface. This condition occurs with some non-asbestos linings. Figure 7.54.

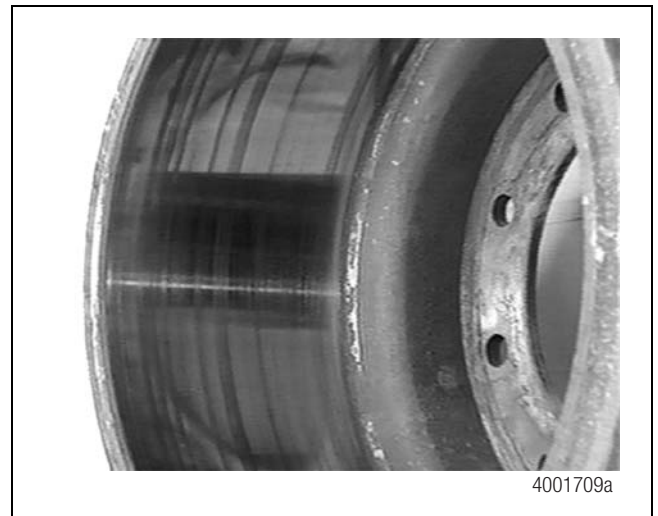

Figure 7.54

7

7 Brakes

Scoring (Grooving)

Scoring (grooving) are depressions in the drum's circumference that are deeper than 0.10-inch and wider than 0.030-inch. Replace the drum and linings. Figure 7.55.

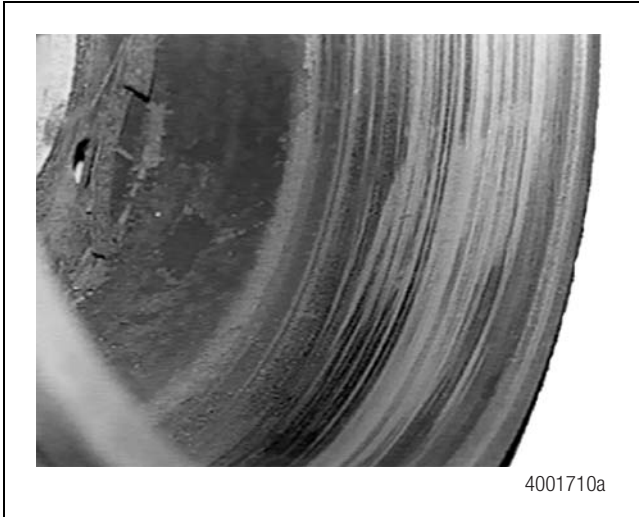

Figure 7.55

“Blue” Drum

The inside of the brake drum has a blue tint, and components can be damaged or deformed. These conditions indicate that extremely high temperatures occurred during operation. Replace the drum. Figure 7.56.

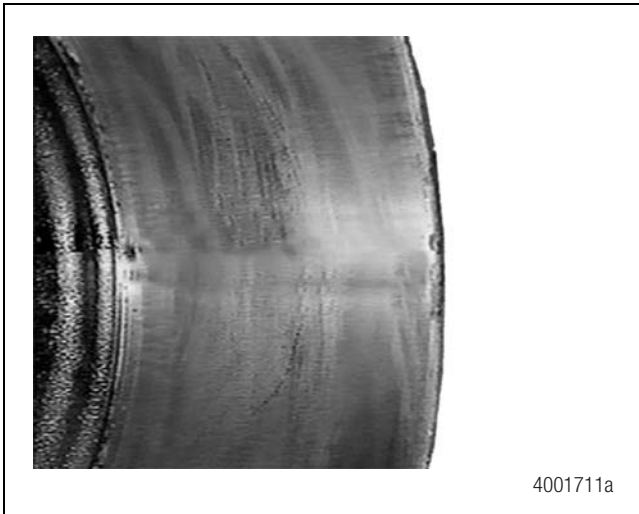

Figure 7.56

Broken Bolt Flange (Brake Surface Not Cracked)

NOTE: The allowable brake drum pilot clearance is 0.001-0.007 inch (0.0254-0.1778 mm).

The bolting flange is broken, but the brake's surface may not have cracked. Figure 7.57. This is a rare condition that usually has been caused by an assembly interference. For example, an incorrect drum was assembled onto a hub or spoke wheel. When the fasteners were tightened, the clamping load cracked the flange.

Broken flanges can also occur if both brake shoes do not simultaneously contact the drum.



Figure 7.57

Broken Bolt Flange (Cracked Brake Surface)

The expanding brake shoes separated the bolt flange from the brake drum, but the flange remained intact. Figure 7.58.



Figure 7.58

Cracked Drum

The drum has cracked, but may not show signs of wear, heat checking or hot spots. Figure 7.59. A drum can crack when the parking brake is set while the brakes are extremely hot. The cooling drum contracted on the brake shoes with enough force to crack the drum.

Brake drum pilot interference with the hub or wheel pilot can also cause the entire cross-section of the drum to crack, if the drum was forced onto the pilot while interference is present.

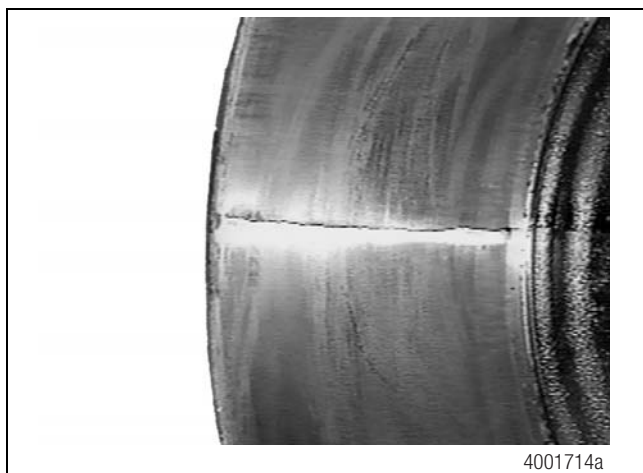

Figure 7.59

4001714a

Worn Brake Drum Bolt Holes

The brake drum bolt holes are worn, usually because the bolts were not tightened to the correct torque specification. The drum pilots may also be worn, and runout in the brake drum may have occurred. The mating hub or wheel pilots may be extensively damaged. Replace both the hub and drum. Figure 7.60.

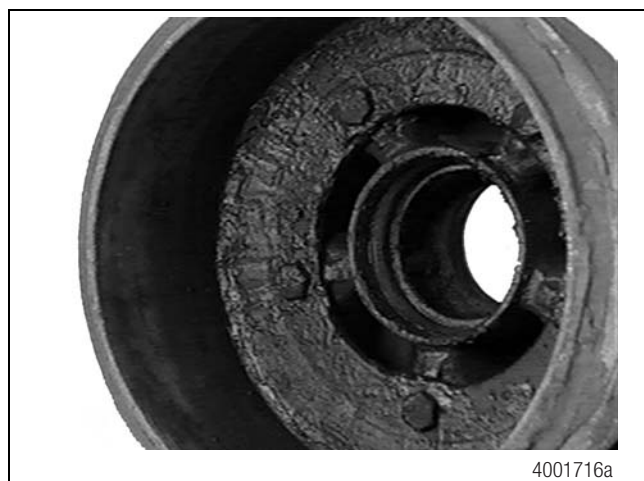

Figure 7.60

4001715a

Oil or Grease Has Penetrated the Drum's Surface; the Drum is Discolored

The brake system has been contaminated with oil or grease when the following conditions are evident. It is difficult to reverse this type of damage, because oil and grease can actually penetrate iron. Figure 7.61.



4001716a

Figure 7.61

1. Oil and grease spots have penetrated the drum's surface.
2. The brake drum is discolored.
3. Oil and grease spots are evident on the components, which resulted from the wheel or hub oil seals that leaked.
4. Replace the drum.

Conditions That Can Affect Brake Drum Wear

Brake Drag

- Worn camshaft bushings
- Relay valves do not work correctly
- Automatic slack adjuster does not work correctly
- Manual slack adjuster set too tight
- Bent air chamber push rods
- Weak or broken air chamber or shoe return springs
- Swelling and growth of new linings
- Total vehicle air brake system imbalance
- Clogged air exhaust ports
- Restricted or pinched air hoses or tubing
- Imbalanced "apply" and "release" threshold pressures

7 Brakes

Too Much Drum-to-Pilot End Play (Gap)

- Mating hub or wheel pilot machined under size
- Hub or wheel pilots not concentric to bearing bores
- Brake drum assembled on contaminated or corroded hub pilots
- Drum incorrectly assembled onto pilot
- Drum not concentric to lining

Drum Seats Incorrectly on the Hub or Pilot Wheel

- Corroded mounting surfaces
- Corroded aluminum hub and drum assembly
- Iron or aluminum hub pilot not cleaned correctly prior to installation

Both Shoes Do Not Simultaneously Contact the Drum

- Brake drum not concentric with the bearing center line of the hub

Heavy Braking

- Inadequate braking system for operation
- Linings not component equipment manufacturer-approved
- Poor driver technique
- High-temperature applications, such as city and construction driving
- Brake imbalance
- Bent spiders; or bent shoes that do not uniformly contact the brake surface

Brake Imbalance

- Pneumatic imbalance between axles
- Relay valves do not work correctly
- Linings are not component equipment manufacturer-approved
- Incorrect brake power (AL Factor)
- Imbalanced “apply” and “release” threshold pressures

Brake Drum Diagnostics

Table BX: Troubleshooting Brake Drum Wear

| Condition | Possible Cause | Corrective Action |
|------------------------------------|--|--|
| Deep, uniform drum wear | Brake drag Brake imbalance Dirt and contaminants imbedded in the brake lining Incorrect driving technique Engine retarder not installed Braking with hand valve Not downshifting on steep grades Exceeding vehicle's brake capacity | Replace the drum. Install dust shields. If dust shields are installed, remove the shields and try operating the vehicle without them. |
| Deep drum wear on one side only | Brake drum dropped, bent or machined out-of-round Drum-to-pilot fit has too much end play, gap | Replace the drum. |
| Worn brake drum bolt holes | Incorrect torque applied to bolt, which also causes hub and drum pilots to wear. Runout also occurs. | Replace the drum. |
| Uniform heat checking, fine cracks | Heavy braking | Replace the drum. |
| Heat checking on one side only | Drum dropped, bent or machined out-of-round Fine cracks on drum's surface from normal operation Drum-to-pilot fit has too much play, gap | Replace the drum. |

Table BX: Troubleshooting Brake Drum Wear

| Condition | Possible Cause | Corrective Action |
|--|---|---|
| Uniform hot spotting, black spots, on the drum's surface | Brake lining and drum mating surfaces burnished too slowly Brake drag Extremely hard linings Lining swell from poor-quality linings | Replace the drum. |
| Hot spotting, black spots, on one side only | Brake drum not concentric to the lining Drum dropped, bent or machined out-of-round Drum-to-pilot fit has too much play, gap | Replace the drum. |
| Hot spotting, black spots, on three equally-distant places | Brake lining and drum mating surfaces burnished too slowly Braking with light, dragging stops Linings not component equipment manufacturer-approved Uneven brake surface contour caused by incorrect manufacturing process Brake drag | Replace the drum. |
| Polished or glazed drums, mirror-like shine | Low-pressure braking Linings not aggressive enough or not component equipment manufacturer-approved | Replace the drum. |
| Scoring, Grooving | Dirt or contaminants in the brake system | Check for dirt embedded in the lining. |
| Deep grooves in the drum's surface that exceed the drum's maximum diameter. Drum can appear to be in good condition. | Linings worn to the rivets or not component equipment manufacturer-approved | Install dust shields. If dust shields are installed, remove the shields and try operating the vehicle without them. |
| "Blue" drum | Braking generates extremely high temperatures caused by axle wheel-end imbalance | Replace the drum. |
| Inside of the brake drum has "blue" tint from excessive heat. Components can be deformed or damaged. | Poor driver techniques Linings not component equipment manufacturer-approved Brake system incorrectly spec'd for the application Brake drag | |
| Cracked drum | The parking brake is set while the brakes are extremely hot. | Replace the drum. |
| Drum has cracked, but may not show signs of wear, heat checking or hot spotting. | The cooling drum contracts on the brake shoes with enough force to crack the drum. Brake drum pilot interference with the hub or wheel pilot Drum cracked prior to assembly | |

7 Brakes

Table BX: Troubleshooting Brake Drum Wear

| Condition | Possible Cause | Corrective Action |
|---|---|---|
| Broken bolt flange, brake surface not cracked | The brake drum pilot interferes with the hub or wheel pilot. Drum cracks at installation. High temperatures cause expanding brake shoes to separate the bolt flange from the drum Incorrect drum assembly on a spoke wheel Brake drum not seated correctly on the hub or pilot wheel Both brake shoes do not contact the drum simultaneously | Replace the drum. |
| Broken bolt flange, cracked brake surface | Excessive wear, heat checking or hot spotting Any combination of the above | Replace the drum. |
| Oil or grease has penetrated the drum's surface; the drum is discolored | Wheel or hub oil seals leak | Attempt to remove oil and grease spots from the drum. If you cannot completely remove the oil and grease spots, you must replace the drum. |
| Oil and grease spots have penetrated the drum's surface and are evident on components. | | |
| Discolored drum | | |

Rotors

Rotors that are damaged or worn beyond the specified thickness can reduce the life of the brake linings.

Inspect the rotors whenever you inspect the brakes.

Measure the thickness of the rotor or disc whenever you reline the brakes.

Rotor Wear Inspection

⚠ CAUTION

You must always replace a damaged rotor or disc.

When you inspect the brakes, inspect both sides and the outer diameter of the rotor or disc for the following conditions. Refer to Brake Drum Wear Conditions in this section for photographs that illustrate these conditions.

- Cracks
- Heat checking
- Grooves or scores
- Blue marks or bands

Measuring the Thickness of the Rotor or Disc

Measure the thickness of the rotor or disc when you reline the brakes. A solid rotor or disc must be at least 0.779-inch (19.8 mm) thick. Rotors or discs with vents must be at least 1.626-inches (41.3 mm) thick. If the thickness of the rotor or disc is less than specification, always replace the rotor or disc. Figure 7.62.

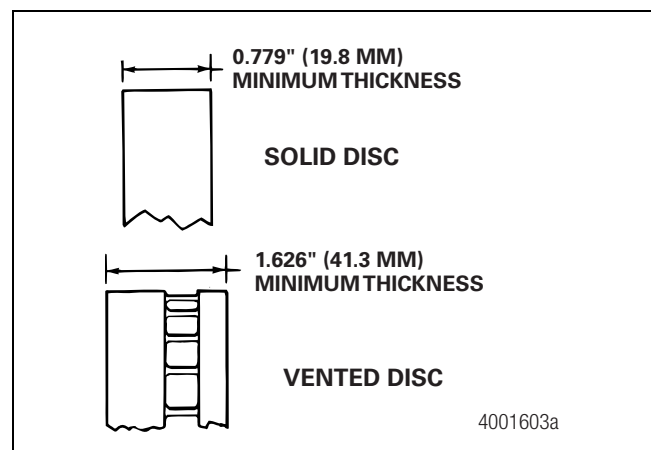

Figure 7.62

Hazard Alert Messages

Read and observe all Warning and Caution hazard alert messages in this publication. They provide information that can help prevent serious personal injury, damage to components, or both.

⚠ WARNING

To prevent serious eye injury, always wear safe eye protection when you perform vehicle maintenance or service.

Park the vehicle on a level surface. Block the wheels to prevent the vehicle from moving. Support the vehicle with safety stands. Do not work under a vehicle supported only by jacks. Jacks can slip and fall over. Serious personal injury and damage to components can result.

Technical Publications

How to Obtain Additional Maintenance and Service Information

Refer to the publications in Table BY. To obtain these publications, refer to the Service Notes page on the front inside cover of this manual.

Table BY: Publications

| Model | Manual |
|--|---------------------------------|
| *Single-Reduction Differential Carriers | Maintenance Manual 5 |
| *Single-Reduction Rear Differential Carriers | Maintenance Manual 5A |
| *Tandem Axle Forward Rear Drive Units | Maintenance Manual 5B |
| *Tandem Axle Forward Rear Drive Units | Maintenance Manual 5C |
| *Tandem Axle Forward Carriers and Single Axle Carriers | Maintenance Manual 5E |
| *Single-Reduction Forward Differential Carriers on Tandem and Tridem Axles | Maintenance Manual 5L |
| *Tandem Axle Forward Rear Drive Units | Maintenance Manual 5P |
| *Tandem Axle Forward Rear Drive Units | Maintenance Manual 6B |
| Double-Reduction Differential Carriers | Maintenance Manual 6C |
| Drive Axle Housings | Maintenance Manual 8 |
| Two-Speed Differentials | Maintenance Manual MM-0144 |
| Rear Drive Axles | Failure Analysis Manual TP-0445 |

* For a complete description of product coverage for each manual, visit Literature on Demand at arvinmeritor.com.

Description

Meritor produces medium- and heavy-duty rear drive axles to suit a wide range of vocations. Models are available in a variety of ratios to meet many performance requirements.

Single rear axles are front mounted into the axle housing and have a hypoid bevel drive pinion and ring gear set with straight bevel gears in the differential assembly.

A tridem is a series of three driving axles configured as follows.

- 1 axle is the forward axle of a normal tandem axle set.
- 2 and 3 axles are a normal tandem set.

Identification

To identify the axle, carrier and housing models, refer to the three identification tags located on the main axle housing. Figure 8.1. Specify the information stamped on these tags when you obtain replacement parts.

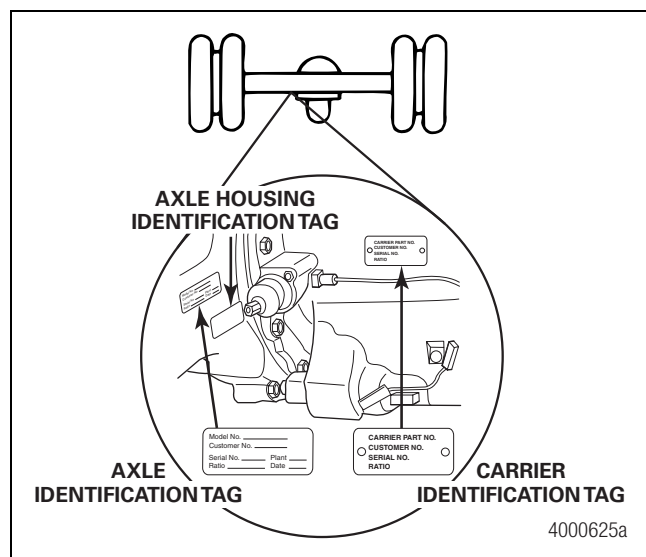

Figure 8.1

8 Rear Drive Axles

Meritor, Rockwell Tags

Meritor and Rockwell tags contain similar information.

The carrier identification tag includes:

- Carrier part number
- Carrier serial number
- Carrier gear ratio

The axle housing identification tag includes:

- Housing part number
- Housing serial number

The axle (carrier and housing assembly) identification tag includes:

- Axle assembly model number
- Axle assembly serial number
- Axle assembly customer number
- Carrier gear ratio

The only difference between brands is the model number.

An example of a Meritor axle assembly model number is:
MD20145DANN123.

An example of a Rockwell axle assembly model number is:
RD20145NFNN123.

Model Nomenclature

Axle Model Numbers and Designations

Refer to Figure 8.2 and Figure 8.3 for an explanation of rear axle model numbers.

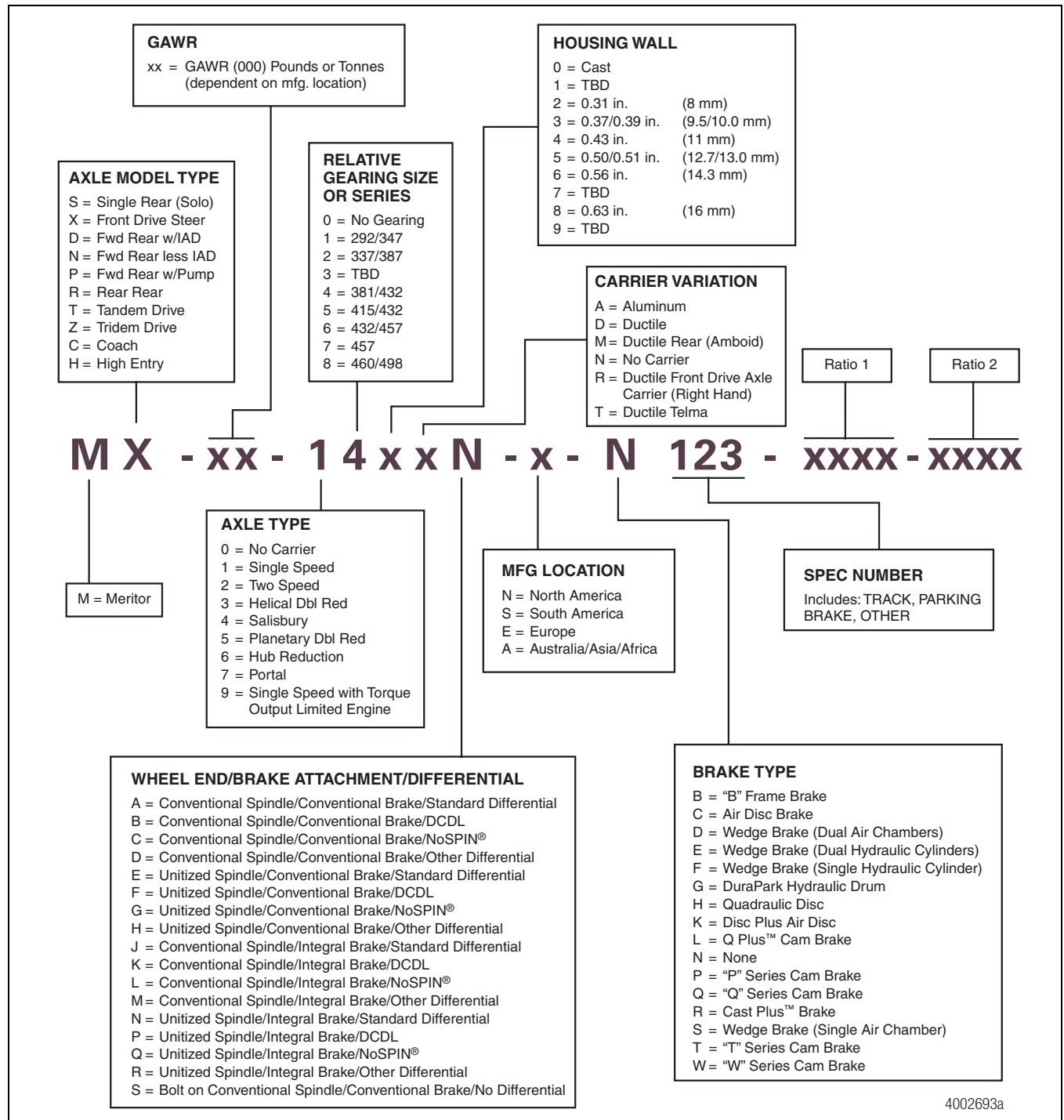

Figure 8.2

8 Rear Drive Axles

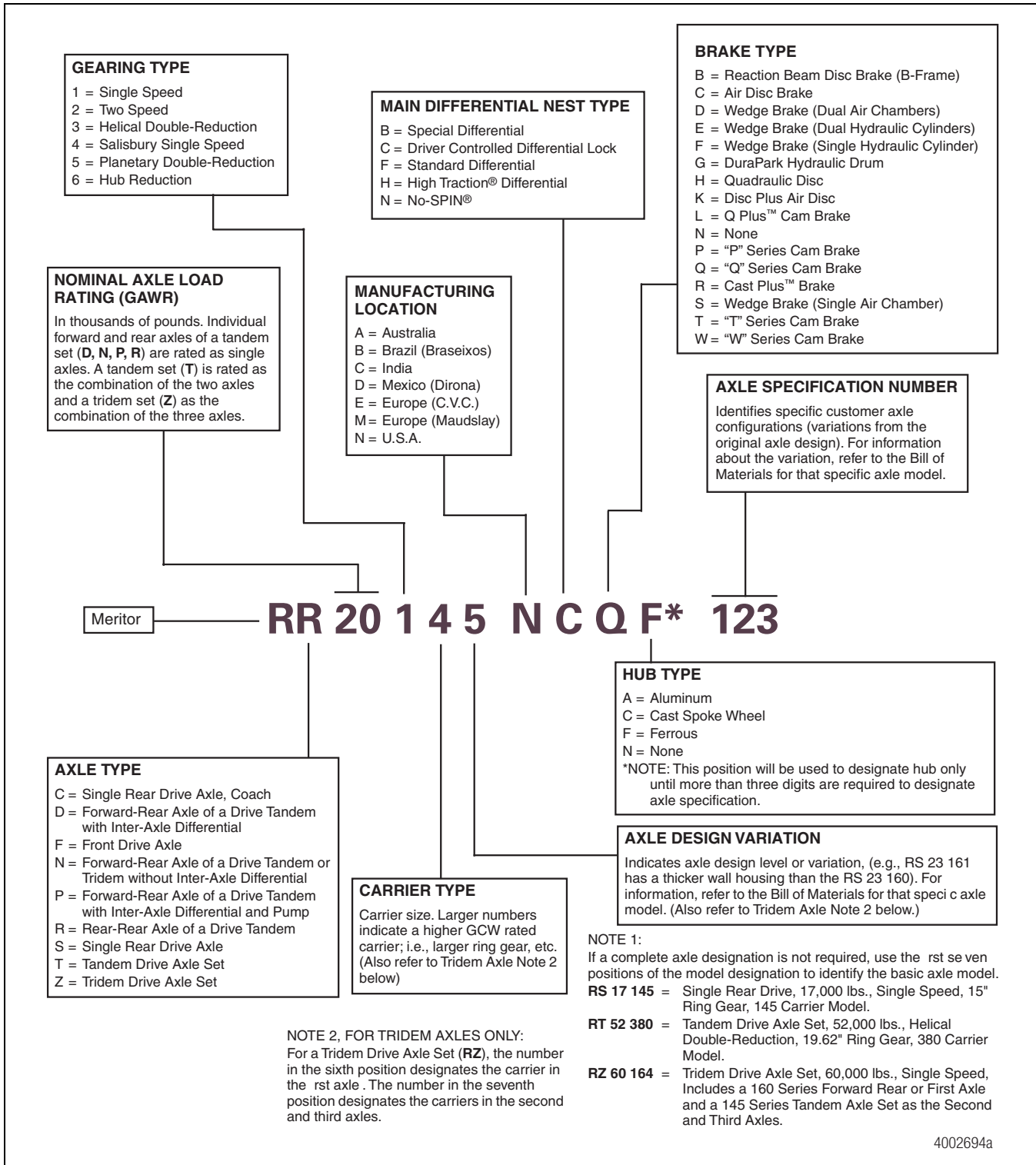

Figure 8.3

Inspection

Carrier

Check magnets and magnetic drain plugs, breathers, seals and temperature indicators during regularly-scheduled oil checks and changes.

CAUTION

Fill axles with specified lubricants only. Filling an axle with non-approved lubricants will void Meritor's warranty. Damage to axle components also can result.

To avoid axle component damage, fill axles with approved lubricants only. Using non-approved lubricants also will void Meritor's warranty.

NOTE: For information on lubricant suppliers, refer to technical bulletin TP-9539, Approved Rear Drive Axle Lubricants. To obtain this publication, refer to the Service Notes page on the front inside cover of this manual.

Magnets and Magnetic Drain Plugs

NOTE: Inspect the magnetic drain plug each time the oil is changed. Use the correct part. Pipe plugs will leak if used as a drain plug.

Although axles are normally equipped with magnetic plugs having a minimum pick-up capacity of 1.5 lbs (0.7 kg) of low carbon steel, Advanced Lube axles have stronger magnetic cleansing features.

These axles are equipped with strong 5-lb (2.2 kg) pull magnets, and high-grade magnetic fill and drain plugs that collect damaging particles at the bottom of the axle housing.

Tandem axles have four magnets in each housing and high-grade magnetic fill and drain plugs. Single axles have six magnets in each housing and high-grade magnetic drain and fill plugs.

Check the drain plug for metal particles every 100,000 miles (160 000 kilometers). A magnetic drain plug can be used if the plug has a minimum pick-up capacity of 1.5 lbs (0.7 kg) of low carbon steel after cleaning.

Breather

CAUTION

Cover the breather when steam cleaning the housing to prevent water from entering the housing and contaminating the oil. Damage to components can result.

Baffle-type breathers release pressure and vacuum condensation to minimize premature oil and component failure.

Temperature Indicators

CAUTION

Axles can operate above 190°F (88°C) without damage. However, if the oil temperature reaches 250°F (121°C), stop the vehicle immediately and check for the cause of overheating. Damage to components can result.

Some axles may have a tapped hole in the housing to install a temperature indicator. A temperature indicator monitors oil temperature and helps to maximize component life, which can be shortened by high oil temperatures that result from severe operating conditions, or unequally inflated and mismatched tires.

Oil Seals

CAUTION

Always use the correct tools and procedures when replacing seals to prevent incorrect installation, leaking seals and damage to components.

Seals keep lubricant in and dirt out of a component. When they are worn or damaged, seals leak and produce damaging low lubricant levels.

Durable triple-lip pinion seals protect the quality and levels of the lubricant and provide superior performance. Advanced Lube axles have triple-lip seals designed to work with current and future lubricants.

8 Rear Drive Axles

How to Recognize a Leaking Seal

If you notice moisture, wetness or oil drips on or around an axle oil seal, it's important to recognize if the seal is leaking, or if it only appears to be leaking.

Inspect the oil seal and surrounding area for wetness. If the seal and area appear very wet or visibly drip oil, or if you notice oil dripping from the bottom of the output seal retainer, replace the seal.

Inspect the yoke for wetness. Check for a leak path leading to the rear lip of the seal. If you notice wetness around the yoke hub or a leak path leading to the rear lip of the seal, replace the seal.

How to Recognize a Seal That Appears to be Leaking

Seals come prelubricated with grease that melts at low temperatures under normal operating conditions. Melted grease can moisten or wet the area between the lip of the oil seal. When this happens, you won't find a leak path leading to the seal. If you notice a moist seal and don't find a leak path, do not replace the seal.

A seal can also become moist from lubricants applied to the yoke or retainer bolts during assembly. When this happens, you won't find a leak path leading to the seal. If you notice a moist seal and don't find a leak path, do not replace the seal.

Seal Test Procedure

1. Thoroughly clean and dry the area around the entire seal retainer casting, especially at the top.
2. Drive the vehicle for 15-20 minutes at highway speeds.
3. Check for wetness or moisture on or around the seal. Also check for oil dripping from the seal. If you notice either of these conditions, replace the seal.

Example 1: The Seal is not Leaking

Cause of Failure

None

What To Look For

The area around the seal is dry. There's no evidence of displaced packing grease or a leak path. Figure 8.4 and Figure 8.5.

Prevention

Follow Meritor's recommended maintenance practices and service procedures.

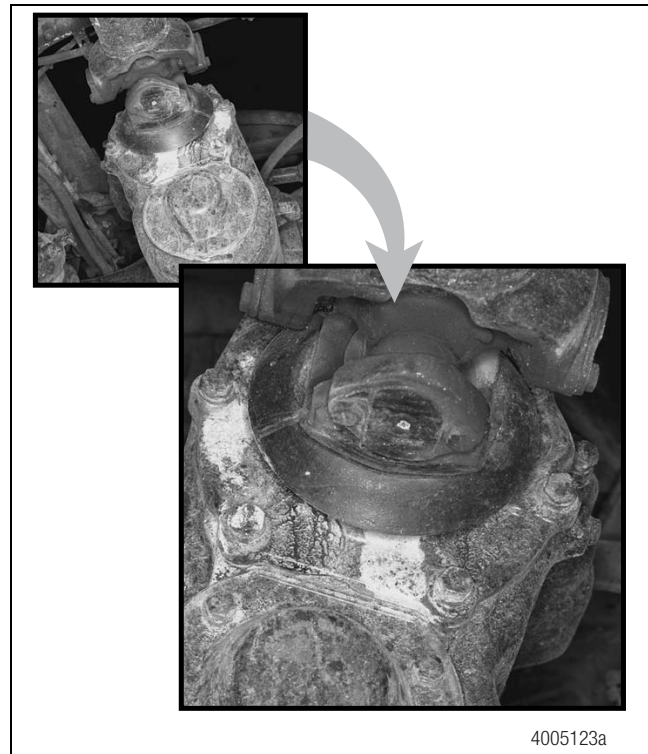

Figure 8.4

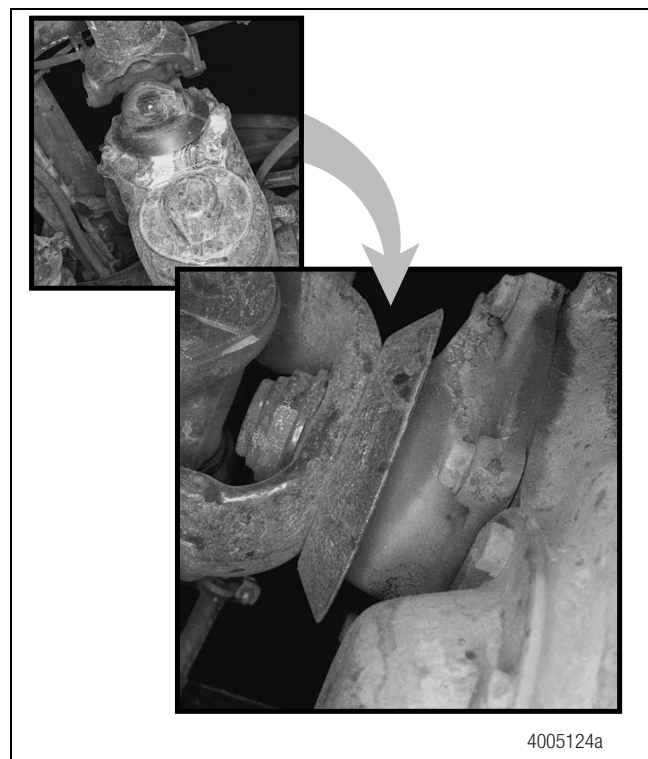

Figure 8.5

Example 2: The Seal Appears to be Leaking

Cause of Failure

A failure is possible. Inspect the seal. If a failure has occurred, determine its cause.

What To Look For

Seals are prelubricated with packing grease that melts at low temperatures during normal operating conditions. In Figure 8.6, you'll see the melted grease at the forward output through-shaft area.

Check the lubricant level. If it's low, replace the seal. If not, monitor the seal for leaks.

Prevention

Follow Meritor's recommended maintenance practices and service procedures.



Figure 8.6

Example 3: The Seal is Leaking

Cause of Failure

Most likely, dirt or contaminants have entered the seal, or the seal's service life is expended.

What To Look For

Inspect the oil seal and surrounding area for wetness. If the seal and area appear very wet or visibly drip oil, or if you notice oil dripping from the bottom of the output seal retainer, the seal requires replacement.

Inspect the yoke for wetness. Check for a leak path leading to the rear lip of the seal. If you notice wetness around the yoke hub or a leak path leading to the rear lip of the seal, replace the seal. Figure 8.7, Figure 8.8 and Figure 8.9.

Prevention

Follow Meritor's recommended maintenance practices and service procedures.

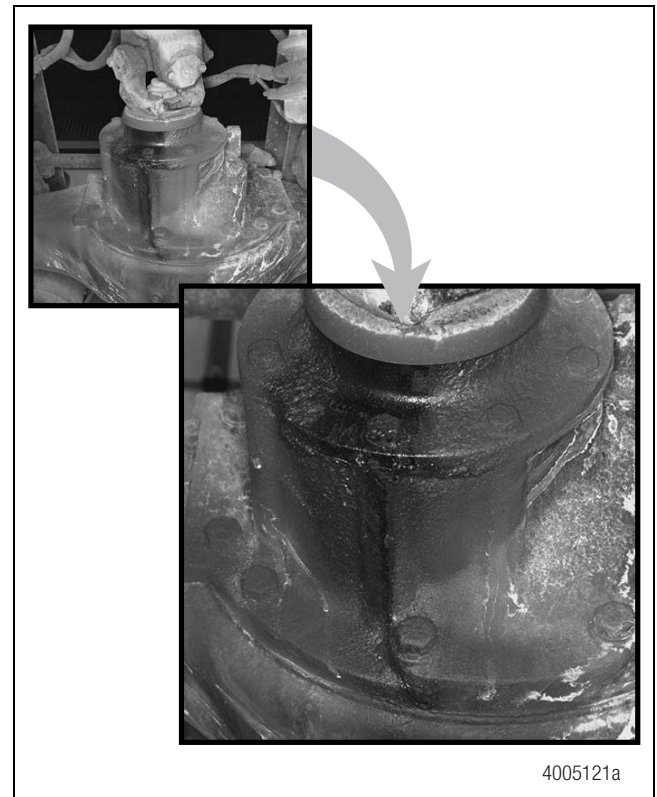

Figure 8.7

8 Rear Drive Axles

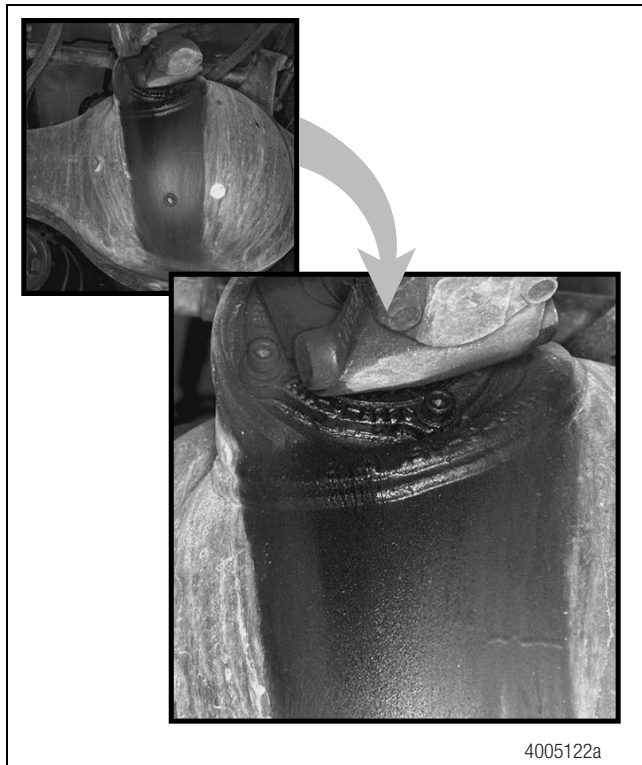

Figure 8.8



Figure 8.9

Lubrication

Advanced Lube Axles

Advanced Lube axles require different drain intervals than other axles. Refer to Table BZ.

The vehicle manufacturer may attach a tag at the axle fill hole or on the inside of the door to identify an Advanced Lube axle. The tag specifies that the axle is filled with semi-synthetic or full-synthetic gear oil.

R-170 Axles Equipped with Traction Equalizer®

R-170 axles with traction equalizer normally operate with either standard petroleum, semi-synthetic gear oils or full-synthetic gear oils.

Limited Slip Friction Modifiers

Occasionally the Traction Equalizer® will slip or stick. When this happens, you will hear intervals of shrill noises when the vehicle operates at low speed or when the vehicle makes sharp turns. You can correct this condition by adding limited slip friction modifiers.

NOTE: Limited slip friction modifiers usually deteriorate more quickly than Extreme Pressure (EP) additives. Shorten the lubricant change schedule when using a friction modifier.

- **At the initial lubricant change interval for an R-170 axle equipped with a Traction Equalizer®:** Replace the factory-installed lubricant with an approved lubricant and one of the additives specified in Table CF.
- **After the initial change interval:** Change the lubricant and the additive at or before 50,000 miles (80 000 km).

Fill Plug Locations

1. If the fill plug is only in the axle housing bowl, use that fill plug. Do not use the temperature sending unit hole. Figure 8.10.

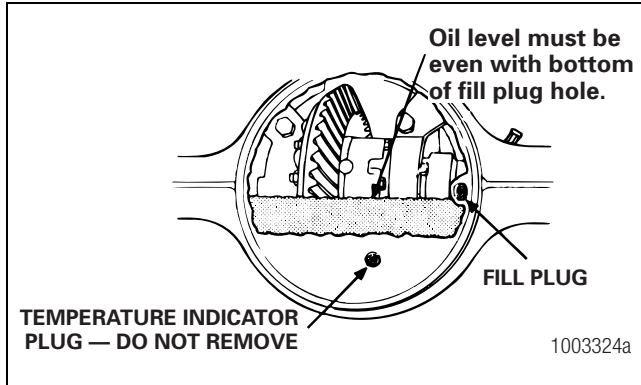

Figure 8.10

2. If the drive pin angle is 7 degrees or less, use the fill plug in the differential carrier. Figure 8.11 and Figure 8.16.
3. If the drive pin angle is more than 7 degrees, use the fill plug in the axle housing bowl. Figure 8.13 through Figure 8.17.

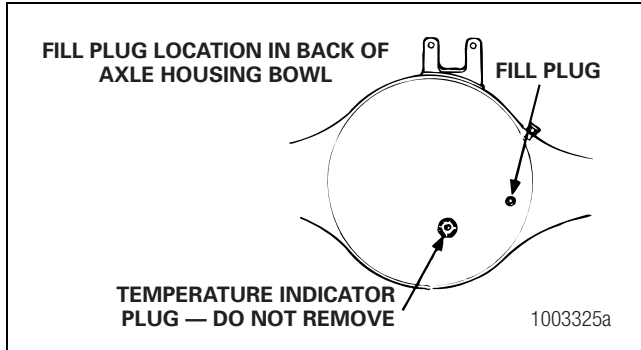

Figure 8.11

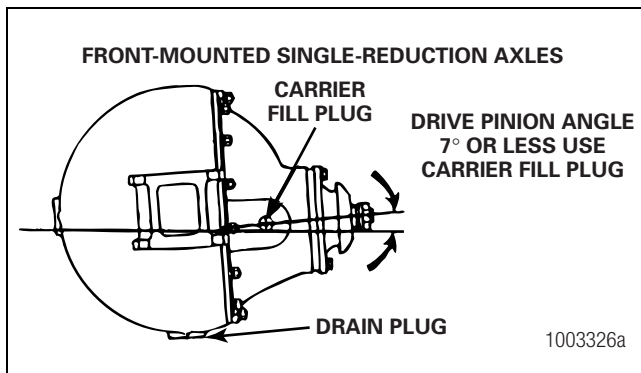

Figure 8.12

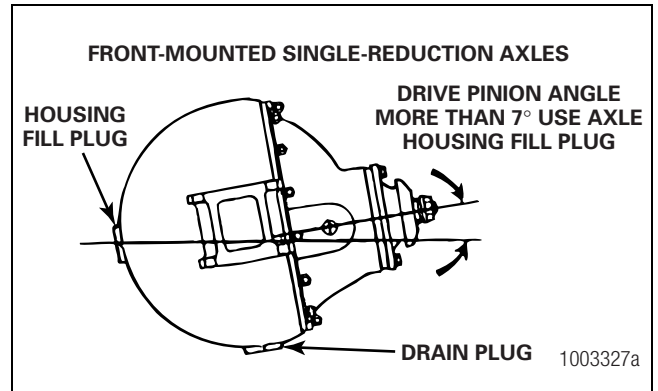

Figure 8.13

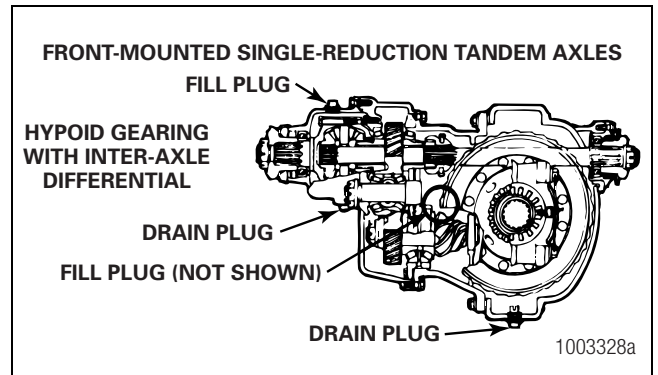

Figure 8.14

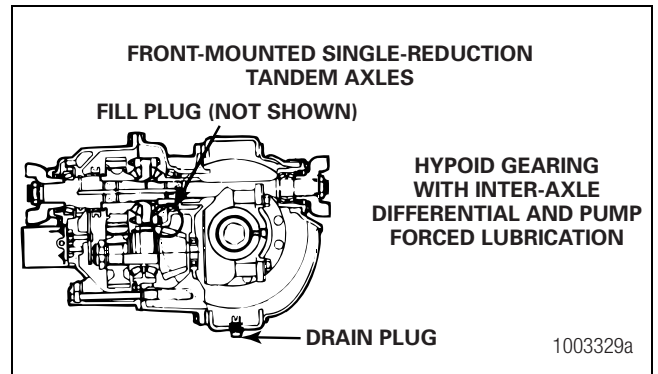

Figure 8.15

8 Rear Drive Axles

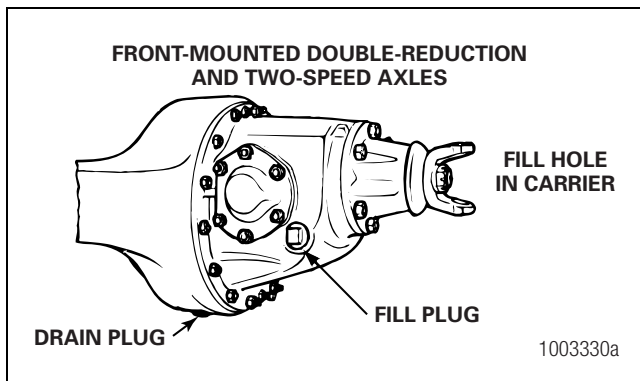

Figure 8.16

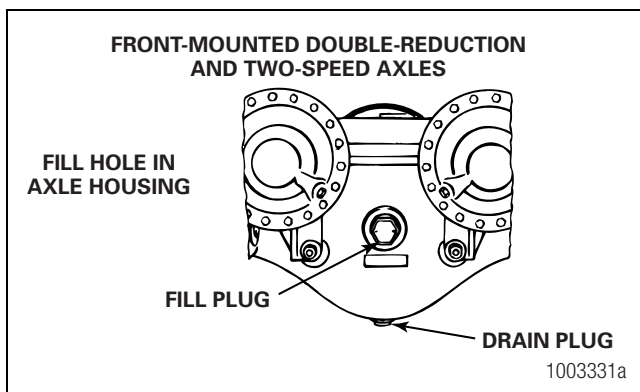



Figure 8.17



Check and Adjust the Oil Level

Check the oil level when the axle is at room temperature. When hot, the oil temperature may be 190°F (88°C) or more and can cause burns. A correct level is not obtained when the axle is warm or hot. Serious personal injury and damage to components can result.

1. Park the vehicle on a level surface. Place blocks under the front wheels to prevent the vehicle from moving. The axle must be cold or near room temperature.
2. Clean the area around the fill plug. Remove the fill plug from the differential carrier or the axle housing bowl, depending on the axle. Do not remove the temperature indicator plug. Figure 8.11 through Figure 8.17.
3. Check the oil level. The level must be even with the bottom of the fill plug hole. Figure 8.10.
4. Install the fill plug. Tighten the plug to 35-50 lb-ft (48-67 N•m). 

Drain and Replace the Oil

NOTE: Drain the oil when it is warm. Remove and replace the oil filters each time the oil is drained.

1. Refer to Fill Plug Locations in this section.
2. Park the vehicle on a level surface. Place blocks under the front wheels to prevent the vehicle from moving. Place a large container under the axle.
3. Install the drain plug. Tighten the plug to 35-50 lb-ft (48-67 N•m). 
 - **If an oil pump is used:** Remove and replace the oil filters.
 - **For Advanced Lube axles:** Replace the oil filter every 100,000 miles (160 000 km).
4. Clean the area around the fill plug. Remove the fill plug from the differential carrier of the axle housing bowl, depending on the axle. Do not remove the temperature indicator plug.
5. Add the specified oil until the oil is even with the bottom of the fill hole. Wait to allow the oil to flow through the axle.
 - **If the inter-axle differential has a top fill plug hole:** Add an additional two pints (0.946 liters) of the same oil into the inter-axle differential housing.
6. Check the oil level again. If necessary, continue to add oil until it is even with the bottom of the fill plug hole.
7. Install the fill plug. Tighten the plug to 35-50 lb-ft (48-67 N•m). 

Inter-Axle Assemblies with Separate Housings

SLHD, SQHD, STDD and SFDD forward-rear tandem axle carrier models include separate housings for inter-axle differential assemblies.

The baffles and dams used in these housings hold a reservoir of oil that can also trap wear particles and debris. Always purge the oil from these reservoirs when changing the axle oil.

These carriers have separate drain and fill holes in either the inter-axle differential cover or housing.

Lubrication Intervals and Specifications

Lubrication Analysis Recommendations

Meritor recommends using a lubricant analysis program. Perform lubricant analysis at regularly-scheduled preventive maintenance intervals. Refer to Section 1 for drive axle differential oil analysis guidelines.

Table BZ: Oil Change Intervals for All Rear Drive Axles

| Vocation or Vehicle Operation | Linehaul | Intercity Coach | City Delivery, School Bus, Fire Truck, Motorhome | Construction, Transit Bus, Refuse, Yard Tractor, Logging, Heavy Haul, Mining, Oil Field, Rescue |
|--|--|--|--|--|
| <u>Initial Oil Change</u> | Not required | Not required | Not required | Not required |
| <u>Check Oil Level</u> Add the correct type and amount of oil as required. | Every 25,000 miles (40 000 km), or the fleet maintenance interval, whichever comes first | Every 25,000 miles (40 000 km), or the fleet maintenance interval, whichever comes first | Every 10,000 miles (16 000 km), once a month, or the fleet maintenance interval, whichever comes first | Every 5,000 miles (8000 km), once a month, or the fleet maintenance interval, whichever comes first ¹ |
| <u>Petroleum-Based Oil</u> Change on axles with or without a pump and filter system. | Every 100,000 miles (160 000 km) or annually, whichever comes first | Every 100,000 miles (160 000 km) or annually, whichever comes first | Every 50,000 miles (80 000 km) or annually, whichever comes first | Every 25,000 miles (40 000 km) or annually, whichever comes first |
| <u>Synthetic Oil</u> Change on axles with or without a pump and filter system. ² | Every 500,000 miles (800 000 km), or every 4 years, whichever comes first | Every 250,000 miles (400 000 km), or every 4 years, whichever comes first | Every 250,000 miles (400 000 km), or every 3 years, whichever comes first | Every 100,000 miles (160 000 km), or every 2 years, whichever comes first ³ |
| <u>Filter Change</u> Change on axles with a pump and filter system. | Every 100,000 miles (160 000 km) | Every 100,000 miles (160 000 km) | Every 100,000 miles (160 000 km) | Every 100,000 miles (160 000 km) |

¹ For continuous heavy-duty operation, check the oil level every 1,000 miles (1600 km).

² This interval applies to approved semi-synthetic and full-synthetic oils only. For a list of approved extended-drain axle oils, refer to TP-9539, Approved Rear Drive Axle Lubricants. To obtain this publication, refer to the Service Notes page on the front inside cover of this manual.

³ The change interval for transit bus can be increased to 150,000 miles (241 401 km) or three years, whichever comes first, contingent upon the following three conditions.

- Documentation verifies a 10% fleet oil sampling with results that are below the guidelines specified in Section 1.
- There is a minimum of six magnets in the housing. Meritor 61163/71163 drive axles come standard with six magnets in the housing.
- Approved extended-drain interval lubricants are used according to TP-9539, Approved Rear Drive Axle Lubricants. (Drive axles excluded are RC-26-633/634 and RC-26/27-720.)

8 Rear Drive Axles

Table CA: Single Rear Drive Axle Oil Capacities

| Axle Model | Oil Capacity* | | Axle Model | Oil Capacity* | |
|------------|---------------|--------|------------|---------------|--------|
| | Pints | Liters | | Pints | Liters |
| A-150 | 5.5 | 2.6 | RS-15-120 | 18.4 | 8.7 |
| B-100 | 10.0 | 4.7 | RS-15-210 | 14.3 | 6.8 |
| B-140 | 12.0 | 5.7 | RS-15-220 | 30.0 | 14.0 |
| B-150 | 3.5 | 1.7 | RS-17-140 | 28.6 | 13.5 |
| C-100 | 12.5 | 5.9 | RS-17-144 | 32.0 | 15.0 |
| D-100 | 12.5 | 5.9 | RS-17-145 | 33.6 | 15.9 |
| D-140 | 12.5 | 5.9 | RS-17-220 | 30.7 | 14.5 |
| E-100 | 15.0 | 7.1 | RS-17-224 | 29.0 | 13.0 |
| E-105 | 12.5 | 5.9 | RS-19-144 | 32.0 | 15.0 |
| E-150 | 9.0 | 4.3 | RS-19-145 | 33.2 | 15.7 |
| F-100 | 13.0 | 6.2 | RS-19-220 | 30.0 | 14.0 |
| F-106 | 13.0 | 6.2 | RS-19-224 | 29.0 | 13.0 |
| F-120 | 15.0 | 7.1 | RS-21-145 | 32.3 | 15.3 |
| F-121 | 15.0 | 7.1 | RS-21-160 | 39.0 | 18.0 |
| F-140 | 14.0 | 6.6 | RS-21-230 | 38.9 | 18.4 |
| G-161 | 21.0 | 9.9 | RS-23-160 | 39.5 | 18.7 |
| H-100 | 20.0 | 9.5 | RS-23-161 | 37.2 | 17.6 |
| H-140 | 21.0 | 9.9 | RS-23-180 | 47.3 | 22.4 |
| H-150 | 11.0 | 5.2 | RS-23-186 | 47.3 | 22.4 |
| H-162 | 20.0 | 9.5 | RS-23-240 | 37.4 | 17.7 |
| H-170 | 27.0 | 12.8 | RS-23-380 | 63.6 | 30.1 |
| H-172 | 27.0 | 12.8 | RS-25-160 | 37.0 | 17.0 |
| L-100 | 23.0 | 10.9 | RS-26-160 | 47.5 | 22.5 |
| L-140 | 24.0 | 11.4 | RS-26-180 | 46.6 | 22.0 |
| L-155 | 24.0 | 11.4 | RS-26-185 | 46.0 | 22.0 |
| L-172 | 27.0 | 12.8 | RS-26-380 | 58.2 | 27.5 |
| M-172 | 27.0 | 12.8 | RS-30-180 | 46.6 | 22.0 |
| Q-100 | 31.0 | 14.7 | RS-30-185 | 46.0 | 22.0 |
| Q-145 | 24.0 | 11.4 | RS-30-380 | 58.2 | 27.5 |
| QT-140 | 24.0 | 11.4 | RS-38-380 | 53.1 | 25.1 |
| R-100 | 30.0 | 14.2 | S-170 | 43.0 | 20.3 |
| R-140 | 28.0 | 13.3 | U-140 | 24.0 | 11.4 |
| R-155 | 28.0 | 13.3 | U-170 | 43.0 | 20.3 |
| R-160 | 28.0 | 13.3 | U-270 | 55.0 | 26.0 |
| R-163 | 34.0 | 16.1 | W-170 | 43.0 | 20.3 |
| R-170 | 43.0 | 20.3 | W-270 | 55.0 | 26.0 |
| R-270 | 55.0 | 26.0 | 59722 | 30.5 | 14.4 |
| RL-170 | 48.0 | 22.7 | 59723 | 30.5 | 14.4 |
| RC-22-145 | 32.3 | 15.3 | 59732 | 30.5 | 14.4 |
| RC-23-160 | 41.0 | 19.4 | 59733 | 30.5 | 14.4 |
| RC-25-160 | 39.5 | 18.7 | 59843 | 30.5 | 14.4 |
| RS-13-120 | 18.4 | 8.7 | 61142 | 42.0 | 19.8 |
| | | | 61143 | 41.0 | 19.3 |

* Oil capacities are for standard track axles that have been measured at various common drive pinion angles. The quantities listed include enough oil for both wheel ends. These oil capacities will change if the track or the drive pinion angle is different.

Table CB: Tandem Rear Drive Axle Oil Capacities

| Axle Model | Carrier | Oil Capacity ¹ | |
|------------------------|--------------|---------------------------|-----------|
| | | Pints | Liters |
| MT-40-143MA-N | Forward Rear | 30.2 25.8 | 14.3 12.2 |
| RT-34-140 | Forward Rear | 26.0 35.0 | 12.3 16.6 |
| RT-34-144 | Forward Rear | 30.0 25.0 | 14.0 12.0 |
| RT-34-145 | Forward Rear | 29.6 25.4 | 14.0 12.0 |
| RT-34-145P | Forward Rear | 25.7 23.4 | 12.1 11.1 |
| RT-40-140 | Forward Rear | 30.2 22.8 | 14.3 10.8 |
| RT-40-145 | Forward Rear | 30.2 25.8 | 14.3 12.2 |
| RT-40-149 | Forward Rear | 30.0 25.0 | 14.0 12.0 |
| RT-40-160 | Forward Rear | 39.1 34.4 | 18.5 16.3 |
| RT-40-169 | Forward Rear | 39.0 34.0 | 18.0 16.0 |
| RT-44-145 | Forward Rear | 29.3 25.1 | 13.9 11.9 |
| RT-46-16HEH/HP | Forward Rear | 38.0 33.0 | 18.0 15.0 |
| RT-46-160 | Forward Rear | 39.1 34.4 | 18.5 16.3 |
| RT-46-164 | Forward Rear | 39.1 34.4 | 18.5 16.3 |
| RT-46-164EH/P | Forward Rear | 38.0 33.0 | 18.0 15.0 |
| RT-46-169 | Forward Rear | 39.0 34.0 | 18.0 16.0 |
| RT-48-180 ² | Forward Rear | 61.1 36.8 | 28.9 17.4 |
| RT-48-380 ² | Forward Rear | 61.1 63.6 | 28.9 30.1 |
| RT-50-160 | Forward Rear | 38.0 33.0 | 18.0 15.0 |
| RT-52-160 | Forward Rear | 44.1 41.2 | 20.9 19.5 |
| RT-52-180 ² | Forward Rear | 56.1 36.1 | 26.5 17.1 |
| RT-52-185 | Forward Rear | 56.1 36.1 | 26.5 17.1 |
| RT-52-380 ² | Forward Rear | 56.1 58.2 | 26.5 27.5 |
| RT-58-180 ² | Forward Rear | 56.1 36.1 | 26.5 17.1 |
| RT-58-185 | Forward Rear | 56.1 36.1 | 26.5 17.1 |
| RT-58-380 ² | Forward Rear | 56.1 58.2 | 26.5 27.5 |
| RT-70-380 ² | Forward Rear | 54.4 53.1 | 25.7 25.1 |
| SFHD | Forward Rear | 17.0 16.5 | 8.0 7.8 |
| SL-100 | Forward Rear | 39.6 37.7 | 18.7 17.8 |
| SLHD | Forward Rear | 32.5 32.0 | 15.3 15.1 |
| SQ-100 | Forward Rear | 39.6 37.7 | 18.7 17.8 |
| SQ-100A | Forward Rear | 39.3 37.6 | 18.6 17.8 |
| SQHD | Forward Rear | 34.0 31.0 | 16.0 14.7 |

| Axle Model | Carrier | Oil Capacity ¹ | |
|------------|--------------|---------------------------|-----------|
| | | Pints | Liters |
| SQHP | Forward Rear | 40.0 36.0 | 18.9 17.0 |
| SR-170 | Forward Rear | 55.0 43.0 | 26.0 20.3 |
| SRHD | Forward Rear | 39.0 36.0 | 18.5 17.0 |
| SSHD | Forward Rear | 34.0 28.0 | 16.0 13.2 |
| ST-170 | Forward Rear | 55.0 43.0 | 26.0 20.3 |
| STHD | Forward Rear | 34.0 28.0 | 16.0 13.2 |
| SU-170 | Forward Rear | 55.0 43.0 | 26.0 20.3 |
| SUHD | Forward Rear | 34.0 28.0 | 16.0 13.2 |
| SW-170 | Forward Rear | 55.0 43.0 | 26.0 20.3 |

¹ Oil capacities are not for standard track axes that have been measured at various common drive pinion angles. The quantities listed include enough oil for both wheel ends. These oil capacities will change if the track or the drive pinion angle is different.

² Forward carrier with oil pump system

Table CC: Oil Quantities for R-170 Axles with and without Traction Equalizer[®]

| With Traction Equalizer [®] | Without Traction Equalizer [®] |
|--|---|
| 40 pints oil (18.9 liters) + 3 pints additive (1.4 liters) | 43 pints oil (20.3 liters) |



8 Rear Drive Axles

Table CD: Tridem Rear Drive Axle Oil Capacities

| Axle Model | Carrier | Oil Capacity* | |
|------------|----------------------|----------------|----------------|
| | | Pints | Liters |
| RZ-166 | Axle 1 Axle 2 Axle 3 | 39.1 39.1 34.4 | 18.5 18.5 16.3 |
| RZ-186 | Axle 1 Axle 2 Axle 3 | 56.1 39.1 34.4 | 26.5 18.5 16.3 |
| RZ-188 | Axle 1 Axle 2 Axle 3 | 56.1 56.1 36.1 | 26.5 26.5 17.1 |

* Oil capacities are not for standard track axles that have been measured at various common drive pinion angles. The quantities listed include enough oil for both wheel ends. These oil capacities will change if the track or the drive pinion angle is different.

Table CE: Rear Drive Axle Oil Specifications

| Gear Oil Type | | A.P.I. Specification | SAE Grade | Meritor Specification | Military/SAE Specification | Outside Temperature |
|-------------------------------|---|----------------------|-----------|-----------------------|------------------------------|----------------------------------|
| Non-Extended Drain Lubricants | Petroleum with EP Additives | GL-5 | 85W/140 | 0-76-A | MIL-PRF-2105 E and SAE J2360 | Above +10°F (-12°C) |
| | | | 80W/140 | 0-76-B | | Above -15°F (-26°C) |
| | | | 80W/90 | 0-76-D | | Above -15°F (-26°C) |
| | | | 75W/90 | 0-76-E | | Above -40°F (-40°C) |
| | | | 75W | 0-76-J | | From -40°F (-40°C) to 35°F (2°C) |
| Extended Drain Lubricants | Petroleum with Extended Drain Additives | GL-5 | 75W/140 | 0-76-L | MIL-PRF-2105 E and SAE J2360 | Above -40°F (-40°C) |
| | | | 80W/90 | — | | Above -15°F (-26°C) |
| | | | 80W/90 | — | | Above -15°F (-26°C) |
| | | | 75W/140 | 0-76-M | | Above -40°F (-40°C) |
| | | | 75W/90 | 0-76-N | | Above -40°F (-40°C) |

Table CF: Limited Slip Friction Modifier Specifications*

| Manufacturer | Specification |
|---------------------------|----------------------|
| DSL-178 | Guardsman Products |
| Equa-Torque 2411 and 2414 | Sta-Lube Corporation |
| Lubrizol 6178 | Lubrizol Corporation |

* For all GL-5 oils, petroleum oil or synthetic, add one of the specified limited slip friction modifiers.

Troubleshooting

All Rear Axles

Contaminated Lubricant Found During Preventive Maintenance

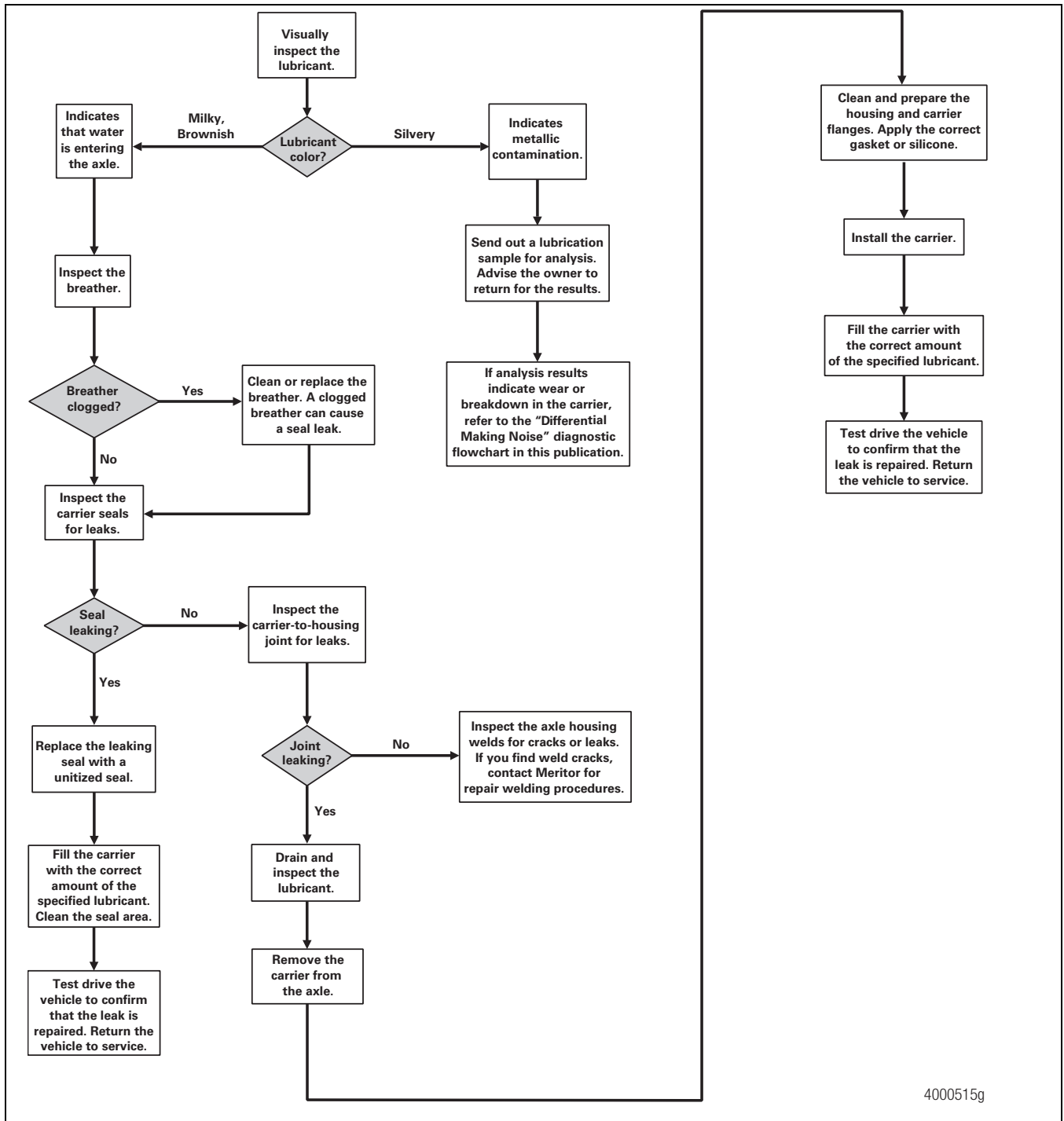

Figure 8.18

4000515g

9 Suspensions

Hazard Alert Messages

Read and observe all Warning and Caution hazard alert messages in this publication. They provide information that can help prevent serious personal injury, damage to components, or both.

⚠ WARNING

To prevent serious eye injury, always wear safe eye protection when you perform vehicle maintenance or service.

Technical Publications

How to Obtain Additional Maintenance and Service Information

Refer to the publications in Table CG. To obtain these publications, refer to the Service Notes page on the front inside cover of this manual.

Table CG: Publications

| Model | Manual |
|---|---------------------------------|
| Trailer Axles | Maintenance Manual 14 |
| RideStar™ RFS Series Trailer Air Suspension Systems | Maintenance Manual 14F |
| RideStar™ RHP Series Single-Axle Trailer Air Suspension System | Maintenance Manual 14L |
| RideStar™ RHP Series Sliding Tandem Trailer Air Suspension System | Maintenance Manual 14S |
| Trailer Axles | Failure Analysis Manual TP-0445 |

RideStar™ RHP Series Trailer Air Suspension Systems

Single-Axle System

The Meritor RideStar™ RHP Series single-axle trailer air suspension system centers around a stabilized parallelogram design that incorporates a single unified frame bracket. The upper and lower control arms are parallel to each other. The air springs mount directly over the axle. Figure 9.1.

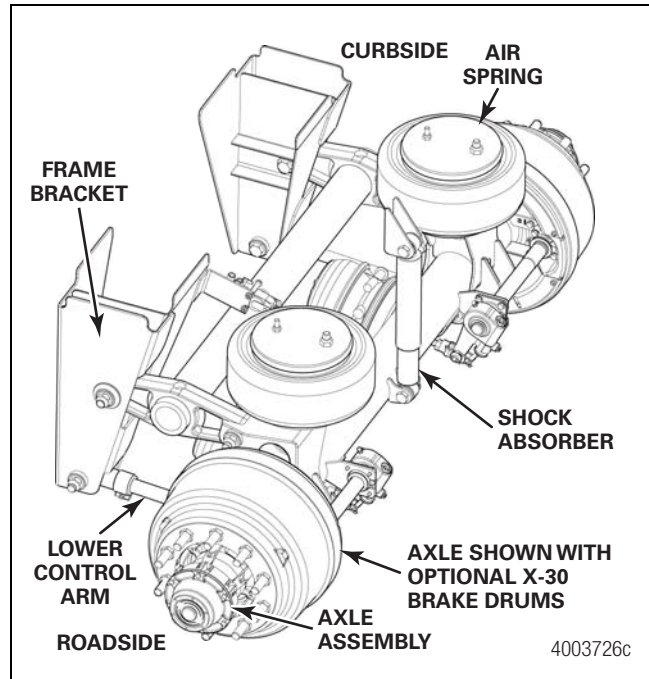

Figure 9.1

Components

- Frame brackets
- Upper and lower control arms
- Axle assembly
- Air springs
- Shock absorber

Features

- A compact 20,000 lb (9072 kg) capacity trailer air suspension system.
- A nominal ride height of 16.5 and 17.5-inches (41.9-44.4 cm) with eight-inches (20.3 cm) of total travel, three-inches (7.6 cm) jounce and five-inches (12.7 cm) of rebound.
- An air system option is available when transporting the trailer by rail car.

Identification

The identification tag is located on the front of the roadside frame bracket. Figure 9.2.

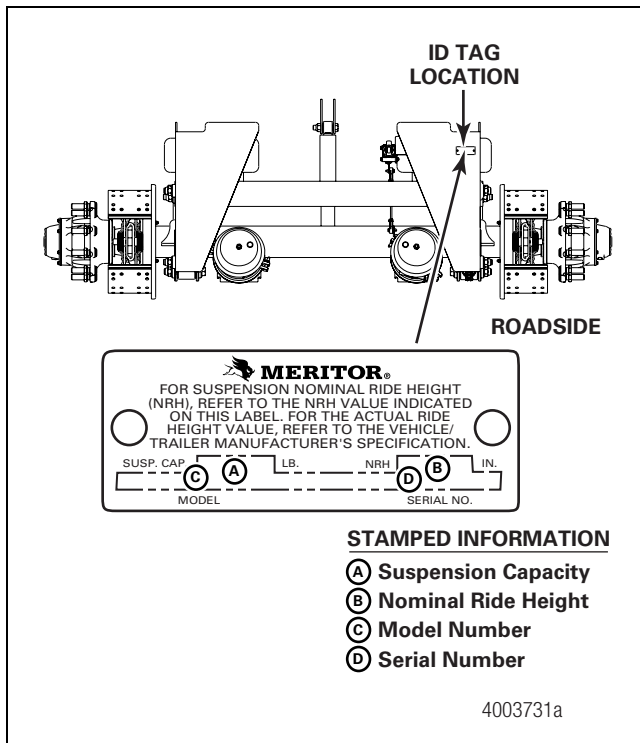

Figure 9.2

The model number on the identification tag provides suspension and axle information. Figure 9.3.

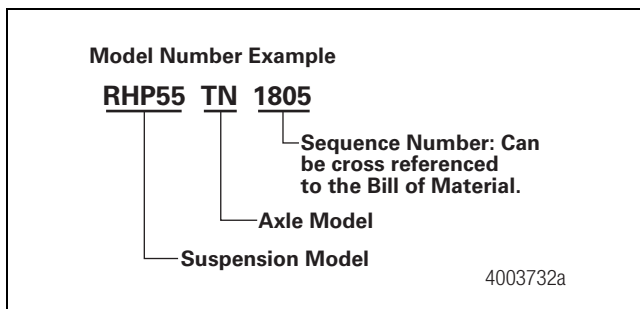

Figure 9.3

Sliding Tandem System

The Meritor RideStar™ RHP sliding tandem trailer air suspension system centers around a stabilized parallelogram design that incorporates a single unified frame bracket. The upper and lower control arms are parallel to each other. The air springs mount directly over the axle. Figure 9.4.

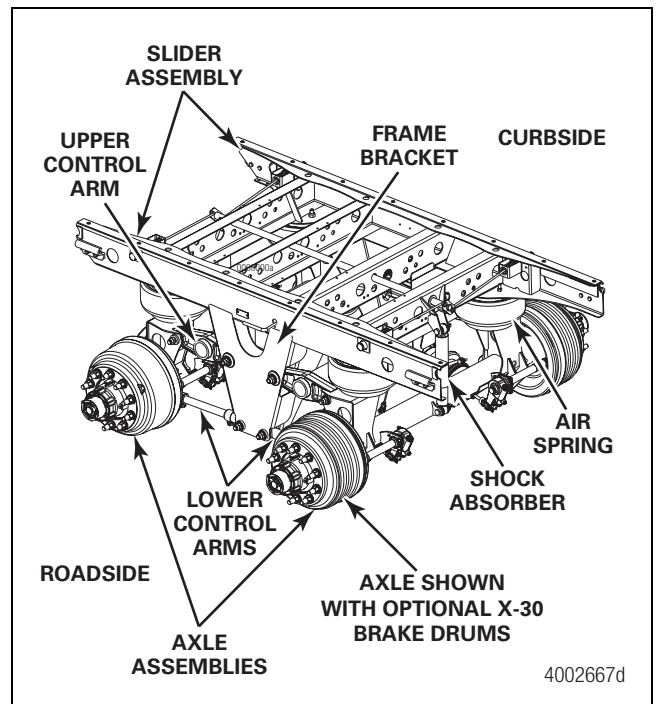

Figure 9.4

Components

- Frame brackets and slider assembly
- Upper and lower control arms
- Axle assemblies
- Air springs
- Shock absorbers

9 Suspensions

Features

- A compact 37,600 lb (17 055 kg) capacity tandem trailer air suspension and slider system designed for sliding tandems.
- A nominal ride height of 16.5-18.5-inches (41.9-47.0 cm) with eight-inches (20.3 cm) of total travel, three-inches (7.6 cm) jounce and five-inches (12.7 cm) of rebound.
- A mounting height of 24.5-26.5-inches (62.2-67.3 cm).
- An air system option is available when transporting the trailer by rail car.

Identification

The identification tag is located on the roadside of the suspension near the pin release handle. Figure 9.5.

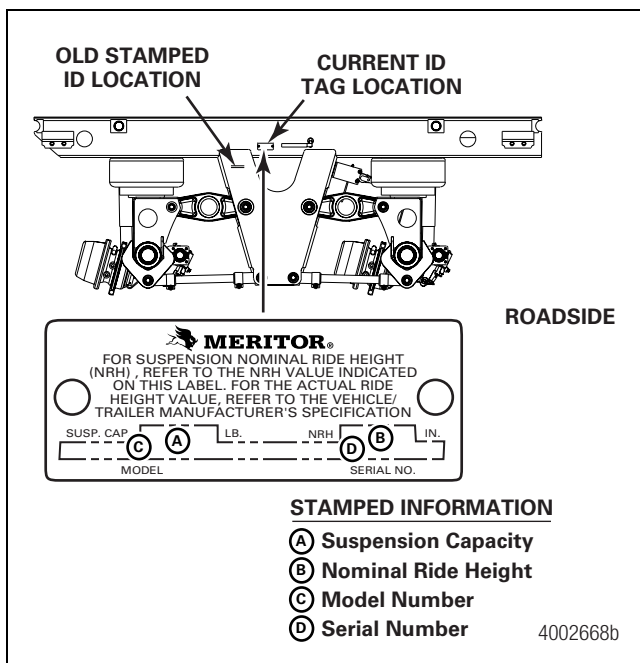

Figure 9.5

The model number on the identification tag provides suspension and axle information. Figure 9.6.

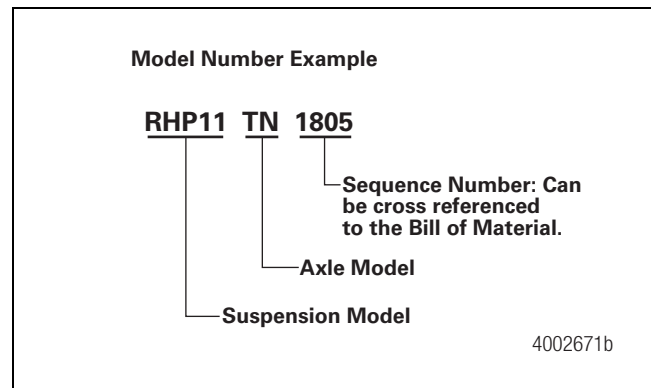

Figure 9.6

Inspection

Single-Axle and Sliding Tandem Suspensions

Inspect the suspension, air suspension components, height control valve and axle at regular intervals during normal operation and each time the trailer is serviced.

- Before each trip, visually inspect the system. Listen for air leaks.

After 1,000 Miles (1600 km) and Annually Thereafter

⚠ WARNING

Check fastener torque values, tighten loose fasteners and replace damaged fasteners. Loose, damaged or missing fasteners can cause loss of vehicle control, serious personal injury and damage to components.

1. Inspect all nuts and bolts for looseness or movement. Tighten loose fasteners to the correct torque. Refer to Maintenance Manual 14L, RideStar™ RHP Series Single-Axle Trailer Air Suspension System; and Maintenance Manual 14S, RideStar™ RHP Series Sliding Tandem Trailer Air Suspension System, for the correct torque specifications. Thereafter, inspect the suspension each time the trailer is serviced.
2. Check for looseness of the alignment pivot bolts. If the bolts are loose, realign the axles prior to retightening the bolts.
3. Replace damaged fasteners to maintain the correct torque specifications and to comply with warranty requirements.

Maintenance

Single-Axle and Sliding Tandem Suspensions

1. Inspect for loose, broken or missing fasteners. Repair or replace as needed.
2. Inspect the welds for cracks at the axle, frame bracket and upper control arm crosstube.
3. Inspect the bushings for ragged or loose pieces that can protrude from the connection area. Use a two-foot (61 cm) pry bar to check for looseness or free play. Also refer to Upper Control Arm Bushing Periodic Inspection Guidelines: All RideStar™ RHP Series Trailer Air Suspension Systems in this section.
 - If looseness or free play exceeds 0.062-inch (1.6 mm) vertical play: Contact the ArvinMeritor Customer Service Center at 800-535-5560.
4. Inspect the flex member of the air springs for cuts and abrasions. Replace the air spring if it is cut or damaged.
5. Check for obstructions or interference to the air spring surface that can damage the air spring. Relocate and secure items, such as air hoses, that can contact the air spring.
6. Check for leaks in the air lines at the air spring bead plate, piston and mounting studs. Replace air lines, fittings or air springs that leak.
7. Inspect the shock absorbers for worn bushings, oil leaks and dents. Check that the mounting holes have not enlarged.
8. After normal operation, check the shock absorbers for heat.
 - Warm shock absorbers most likely indicate that the shock absorbers are operating correctly.
 - Cold shock absorbers can indicate that the shock absorbers are not operating correctly and must be replaced. Replace the shock absorbers as necessary.
9. Inspect the structure of the suspension. Figure 9.7 and Figure 9.8. Inspect the following items.
 - Upper axle seats
 - Upper control arms
 - Lower axle seats
 - Lower control arms
 - Axle welds
 - Brake interference, cam or chamber
 - Frame brackets
 - Shock absorber brackets

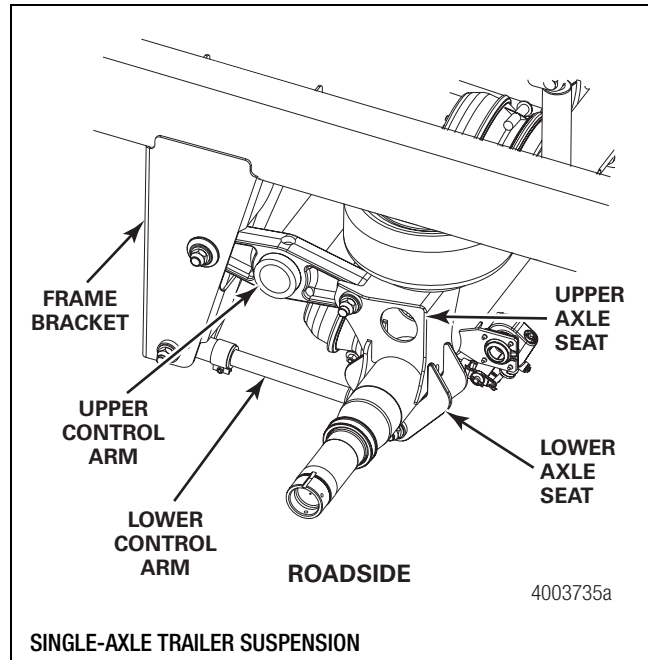

SINGLE-AXLE TRAILER SUSPENSION

Figure 9.7

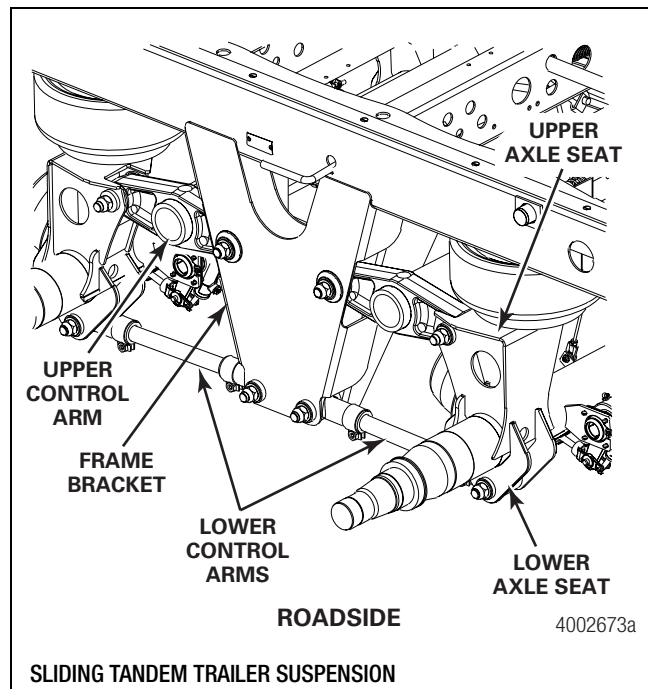

SLIDING TANDEM TRAILER SUSPENSION

Figure 9.8

9 Suspensions

Upper Control Arm Bushing Periodic Inspection Guidelines: All RideStar™ RHP Series Trailer Air Suspension Systems

Meritor recommends conducting a visual inspection of the RideStar™ RHP Series air suspension system whenever routine maintenance is performed. The purpose of the inspection is to determine the condition of the two-piece urethane bushings located within the upper control arm bushing tubes. Being aware of certain wear trends of this part will ensure that excessive wear to the upper control arm, frame bracket and axle seat does not occur causing the component to be replaced.

Follow these instructions to inspect the upper control arm bushings without performing disassembly procedures underneath the trailer.

WARNING

To prevent serious eye injury, always wear safe eye protection when you perform trailer maintenance or service.

Park the trailer on a level surface. Block the wheels to prevent the trailer from moving, which can cause serious personal injury and damage to components.

1. Wear safe eye protection.
 2. Park the trailer on a level surface. Block the wheels to prevent the trailer from moving.
 3. You do not need to lift the tires off the ground. Do not remove the tires.
 4. Use a flashlight to visually inspect all eight upper control arm bushings to determine bushing condition.
5. Inspect the upper control arm and bushing for the following conditions.
 - A. The bushing flanges are intact on both sides of the bushing tube, and everything is centered within the frame bracket or axle seat, which is the correct position for the upper control arm and bushing. Figure 9.9.

If the position is correct, insert a two-foot (0.61 m) pry bar between the upper control arm and the bottom of the axle seat to measure the free play gap.

 - **If the bushing free play gap exceeds 1/16-inch (1.588 mm) at either the axle seat or the frame bracket:** Replace the bushings. **Note:** Even if the free play gap exceeds the specification for one bushing, you must replace all eight bushings at the next available opportunity.
 - **If the bushing free play gap is less than 1/16-inch (1.588 mm) for all the bushings:** The bushings are not worn. Do not replace the bushings.
 - B. The upper control arm and bushing have shifted slightly to one side. The bushing flange is worn, torn or missing. You don't find significant wear between the upper control arm and the frame bracket or axle seat. The free play gap is less on one side than the other side. Figure 9.10.
 - **If you find these conditions:** Replace the bushing at the next available opportunity.
 - C. The upper control arm and bushing have shifted and clamped to one side. The bushing flange is missing on one side. The upper control arm is pinned against the frame bracket. Significant wear exists between the upper control arm and the frame bracket or axle seat. There is no free play gap on one side, and a large gap on the other side. Figure 9.11.
 - **If you find these conditions:** Replace the bushing immediately to prevent damage to components.

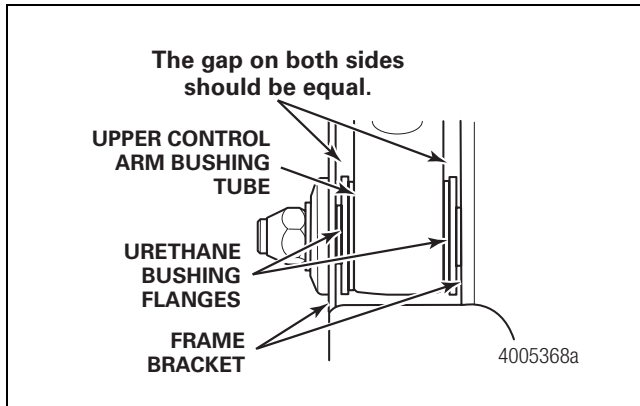

Figure 9.9

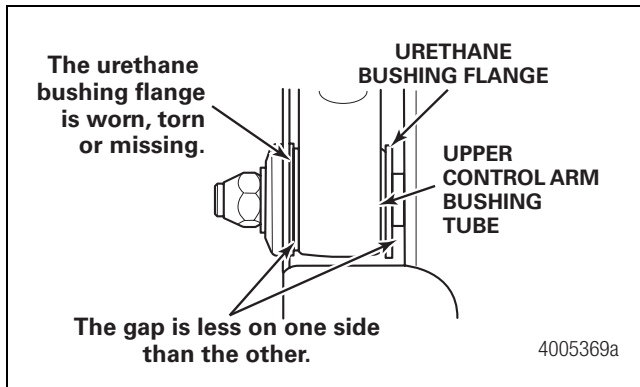

Figure 9.10

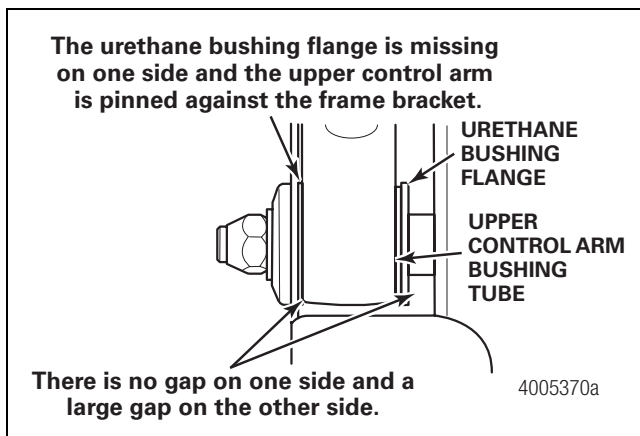

Figure 9.11

Slider on Sliding Tandem Suspension System

1. Inspect for loose, broken or missing fasteners. Repair or replace as needed.
2. Check the slider locking pins, slider pull-bar mechanism and slider wear pads for signs of excessive wear or binding. Figure 9.12. Repair or replace as needed.
3. Inspect the structure of the slider box and crossmembers for damage. Repair as needed.
4. Inspect the front and rear hold down clips to ensure that they are secured correctly around the body rails.

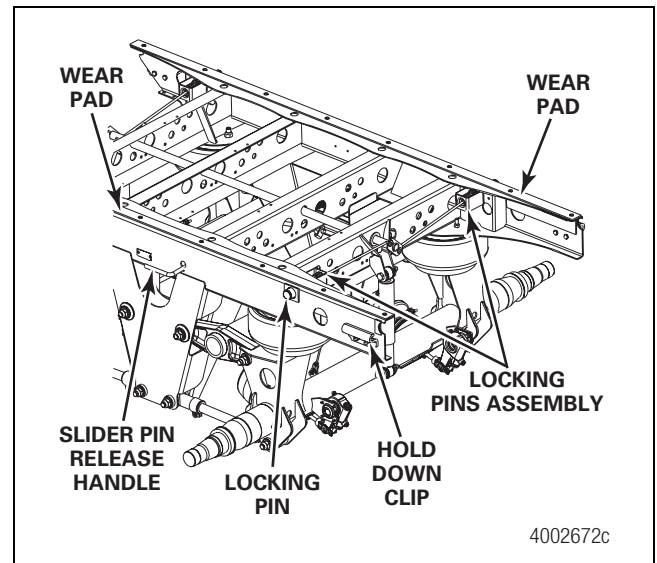

Figure 9.12

9 Suspensions

RideStar™ RFS Series Trailer Air Suspension System

The Meritor RideStar™ RFS Series air suspension system is designed with trailing arms mounted onto the axle, parallel to each other and perpendicular to the axle. A pivot bushing, hanger assembly and alignment collars are mounted to the front of each trailing arm. The rear of the trailing arm supports the air spring. Figure 9.13.

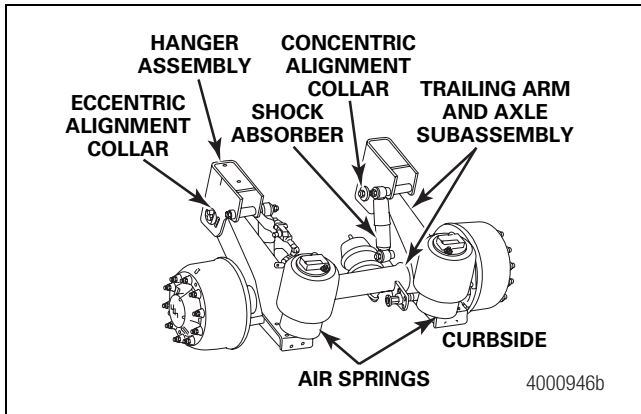

Figure 9.13

Model Nomenclature

An identification tag is located on the rear of the roadside trailing arm. To obtain replacement parts, refer to the Service Notes page at the beginning of this manual and specify the model number on the tag. Figure 9.14.

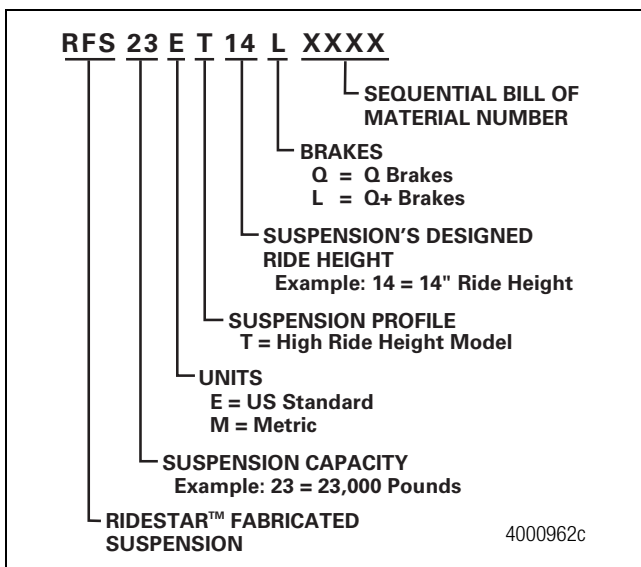

Figure 9.14

Ride Height

Ride height is the distance from the centerline of the axle to the underside of the trailer frame. Figure 9.15.

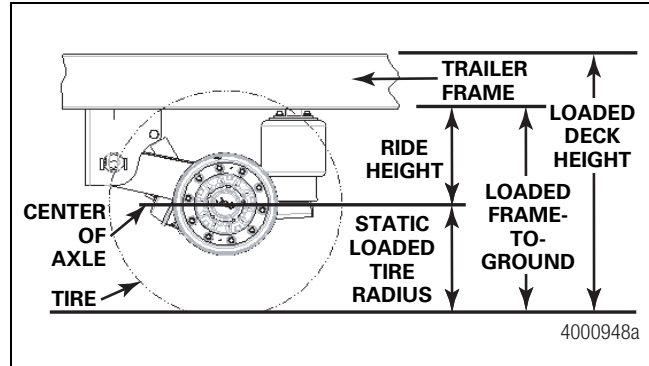

Figure 9.15

All Meritor air suspensions are designed to operate at a specific ride height, which must be maintained during the life of the suspension. Otherwise incorrect loading can occur, which can affect suspension performance, shorten component life and void the Meritor warranty.

Operating a vehicle with ride height higher than specified by the application can cause the trailer to be over the legal height limit, depending on the type of trailer and payload.

To obtain the correct ride-height specification, check the suspension's identification tag located on the rear of the ROADSIDE trailing arm. Also refer to Model Nomenclature.

How to Determine the Correct Ride Height

Consider the following factors when you determine the correct suspension ride height.

If a variation of suspension ride height is required at each location, contact ArvinMeritor's Customer Service Center at 800-535-5560 for assistance.

Frame-to-Ground Distance

You must measure the distance from the bottom of the trailer frame to the ground at each suspension location. Figure 9.16. This measurement determines the required trailer deck height.

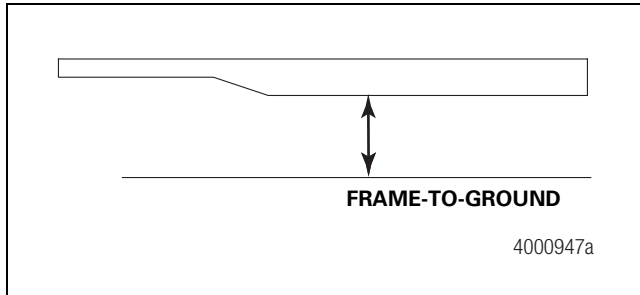

Figure 9.16

Trailer Deck Height

To calculate the required suspension ride height, subtract the tire's static loaded radius from the loaded frame-to-ground dimension. Figure 9.15.

Fifth-Wheel Height

A trailer frame's fifth-wheel height can affect the slope of the trailer frame. For example, a low fifth-wheel height will cause the trailer frame to slope DOWNWARD toward the front. Determine the correct ride height at each suspension. Figure 9.17.

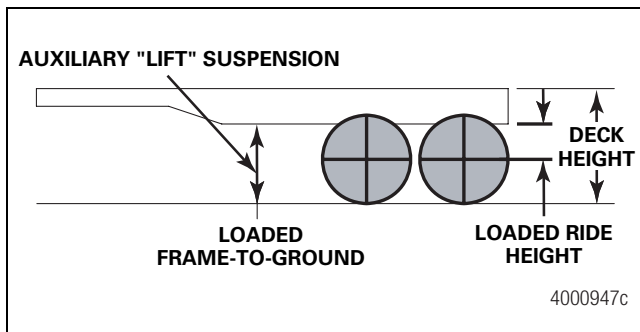

Figure 9.17

Trailer Frame Deflection

When the suspension was installed, ride height was determined without a load on the trailer. Trailer frame deflection can occur when the trailer is loaded and will change ride height. Be sure to allow for frame deflection when you determine the correct ride height at each suspension. Figure 9.18.

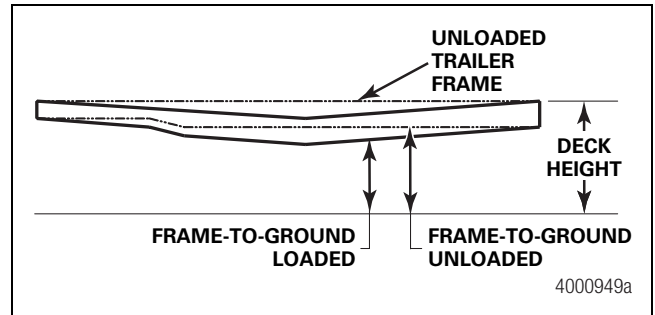

Figure 9.18

Auxiliary Air Suspension Lift Axles (Loaded Frame-to-Ground)

You must determine the loaded frame-to-ground measurement of auxiliary air suspension lift axles at each suspension location. Figure 9.19. A leaf-spring suspension's ride height changes under various loads and the auxiliary lift axles must be spec'd to meet the ride height of the loaded leaf-spring suspension for correct operation.

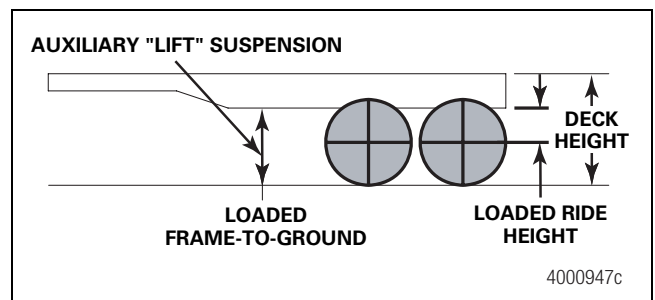

Figure 9.19

Jounce and Rebound

Jounce is the amount of upward axle travel from the suspension's designed ride-height position. Figure 9.20.

Rebound is the amount of downward axle travel from the suspension's designed ride-height position. Figure 9.20.

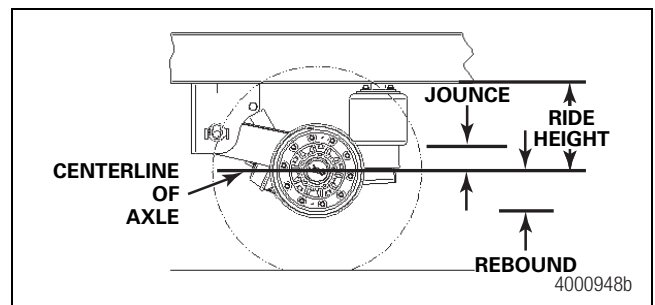

Figure 9.20

9 Suspensions

Tire Clearance

Meritor air suspensions require a 1.5-inch (38 mm) minimum tire clearance between the top of the tire and the bottom of the trailer frame structure above the tire when the suspension is at full jounce. Figure 9.21.

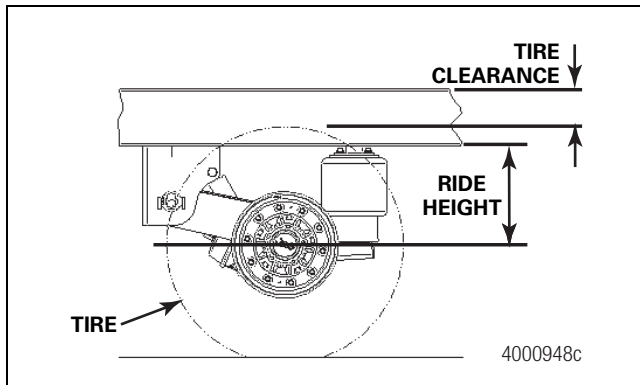

Figure 9.21

How to Determine Tire Clearance

Determine tire clearance by adding the specified tire clearance to the suspension jounce. This sum is the distance required between the top of the tire and the bottom of the trailer frame when the suspension is at its designed ride height.

Example

- Jounce = 3-inches (76 mm)
- Tire Clearance = 1.5-inches (38 mm)

Calculation

3-inches (76 mm) + 1.5-inches (38 mm) = 4.5-inches (114 mm) =
Space required above the tire at ride height

A two-inch (51 mm) clearance is required between the inside of the tire and the trailer frame on each side. This clearance allows for both lateral movement of the suspension and tire deflection. Figure 9.22.

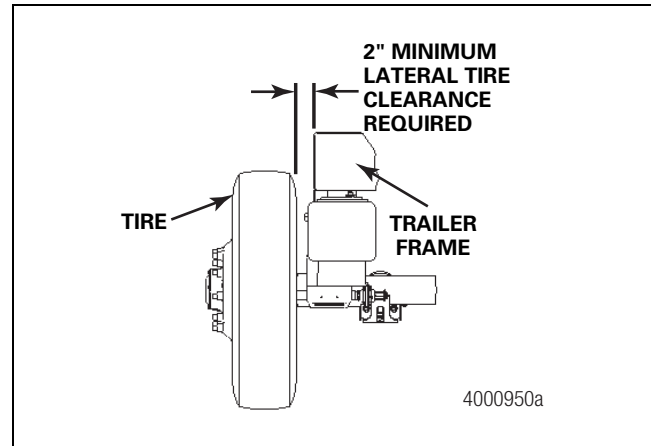

Figure 9.22

Maintenance

Inspect air suspension components, the height control valve and axle at regular intervals during normal operation and each time the trailer is serviced.

Before each trip, visually inspect the suspension system and listen for any air leaks.

Replace damaged fasteners to maintain correct torque value specifications and comply with warranty requirements.

Perform the following inspections after the first 1,000 miles (1600 km) of operation and annually thereafter.

1. Check fastener torque values, tighten loose fasteners and replace damaged or missing fasteners.
2. Visually inspect all nuts and bolts for looseness and movement. Figure 9.23. Tighten loose fasteners to the correct torque values. Thereafter, inspect the suspension components each time the trailer is serviced.
3. Check for loose pivot bolts.
 - **If the bolts are loose:** Align the axles before tightening the bolts.

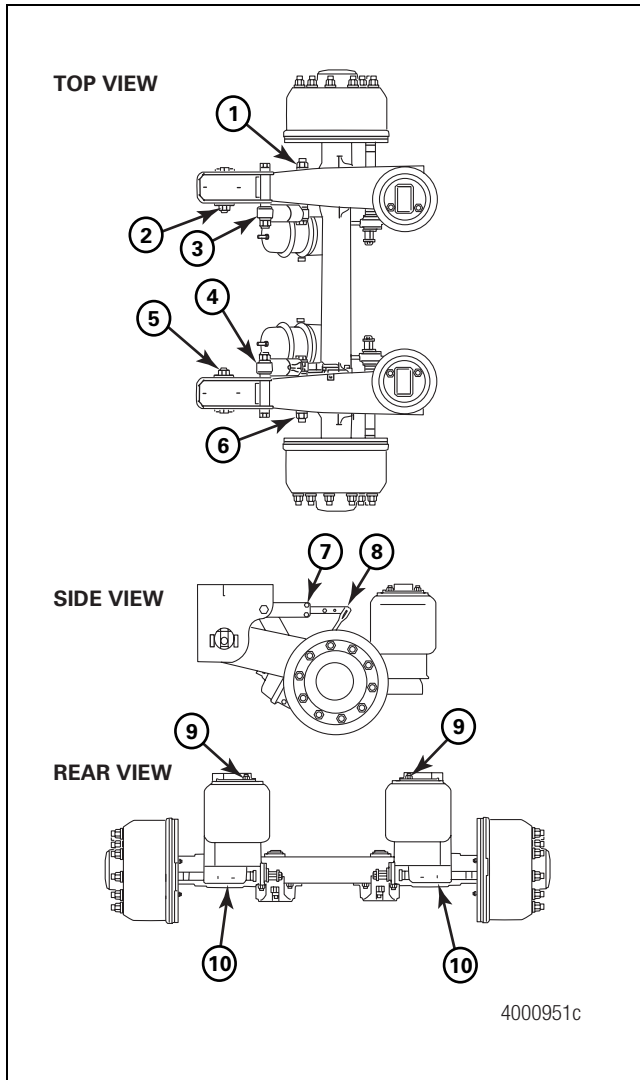

Figure 9.23

| Item | Description |
|------|-------------------------------------|
| 1 | Curbside Lower Shock Bolt |
| 2 | Curbside Pivot Bolt |
| 3 | Curbside Upper Shock Bolt |
| 4 | Roadside Upper Shock Bolt |
| 5 | Roadside Pivot Bolt |
| 6 | Roadside Lower Shock Bolt |
| 7 | Height Control Valve Mounting Bolts |
| 8 | Height Control Valve and Linkage |
| 9 | Upper Air Spring Nut(s) |
| 10 | Lower Air Spring Nut(s) |

1. Inspect for broken and missing fasteners. Repair or replace as needed.
2. Inspect welds for cracks at the trailing arm and axle subassembly and hanger assemblies.
3. Inspect the flexmember of the air springs for any cuts and abrasions. Replace the air spring immediately if it is cut or damaged.
4. Check for obstructions and interference at the air springs that may cause scuffing and abrasions. Relocate and secure items such as air hoses that can contact any part of the air spring.
5. Check for leaks in the air lines, at the air spring upper bead plate, piston and mounting studs. Figure 9.24. Replace leaking air lines, fittings or air springs.

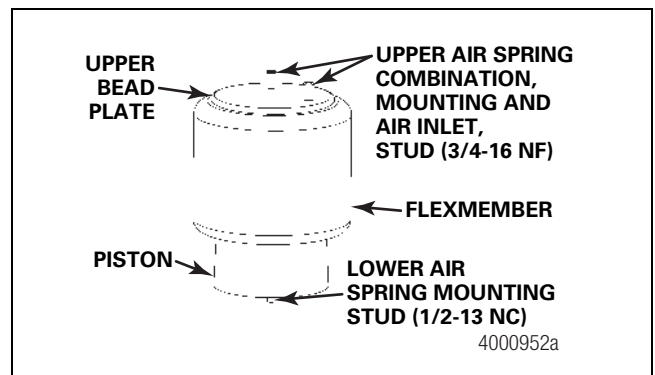

Figure 9.24

6. Inspect the structure of the following air suspension components. Figure 9.25.
 - Hanger assemblies
 - Trailing arm and axle subassembly
 - Shock mountings
 - Axle-to-trailing arm connection
 - Brake interference, cam or chamber
 - Hanger assembly bracing at interface points
 - Pivot connections

9 Suspensions

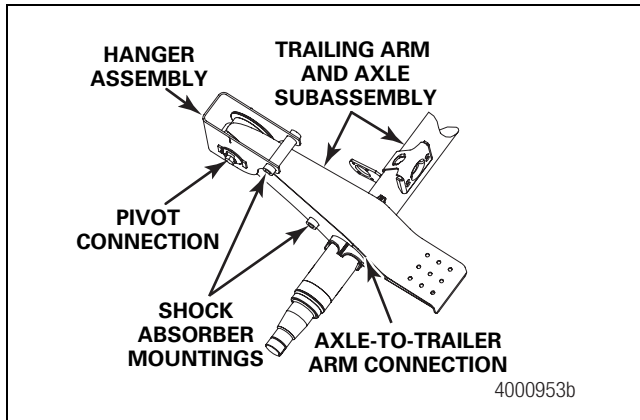

Figure 9.25

Inspect the Shock Absorbers

1. Check the shock absorber bushings for looseness and wear. Inspect the shock absorbers for oil leaks and dents. Replace worn or damaged shock absorbers. Figure 9.26.

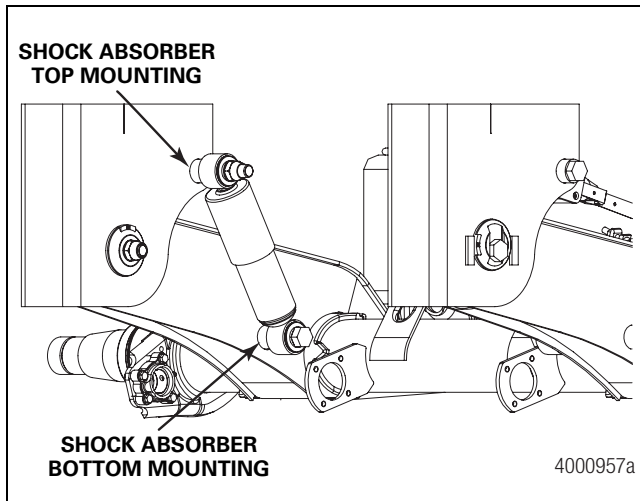

Figure 9.26

2. Inspect the shock absorbers to determine that washers are installed at the shock absorber upper and lower pivot connections, and shock absorber bushing migration is evident. Refer to the following procedure.

What to Look for and Actions Required

| What to Look for | Actions Required |
|--|--|
| Washers ARE NOT installed at the upper and lower shock absorber pivot connections, and bushing migration IS NOT evident. | Install new washers (Meritor part number 1229-M-4979). |
| Washers ARE NOT installed at the upper and lower shock absorber pivot connections, and bushing migration IS evident. | Install a replacement shock absorber (Meritor part number A-7805-L-1026) with new washers (Meritor part number 1229-M-4979). |

Installing the New 2-1/4-inch O.D. (57.15 mm) Washers Without Replacing the Shock Absorber

⚠ WARNING

To prevent serious eye injury, always wear safe eye protection when you perform vehicle maintenance or service.

Park the vehicle on a level surface. Block the wheels to prevent the vehicle from moving. Support the vehicle with safety stands. Do not work under a vehicle supported only by jacks. Jacks can slip and fall over. Serious personal injury and damage to components can result.

Verify that all personnel are clear of the trailer before you inflate or deflate the air springs. The air suspension system has various pinch points that can cause serious personal injury.

1. Wear safe eye protection.
2. Park the trailer on a level surface. Block the wheels to prevent the trailer from moving. Correctly support the trailer.
3. Remove the 7/8-inch (22.23 mm) nut and 7/8-inch x 1-3/4-inch O.D. (22.23 x 44.45 mm) washer from the UPPER shock absorber mounting. Discard the washer. Do not remove the existing washer on the shock absorber bolt. Figure 9.27.

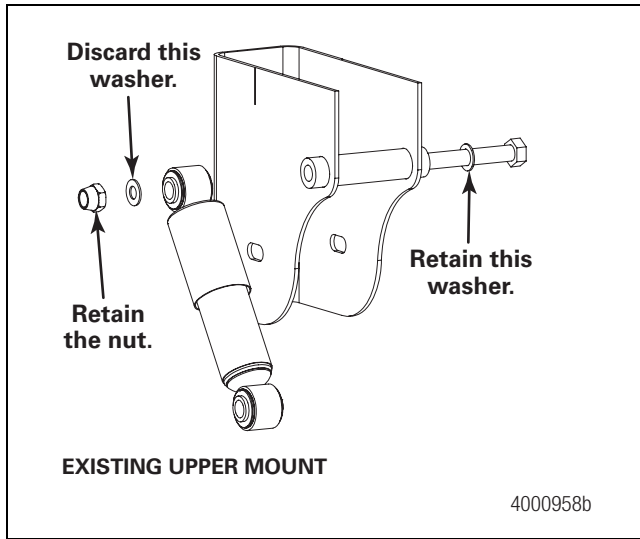

Figure 9.27

4. Install the new 7/8-inch x 2-1/4-inch O.D. (22.23 x 57.15 mm) washer between the shock tube and shock absorber. Install the new, larger washer between the shock absorber and locknut. Hand-tighten the nut. Figure 9.28.

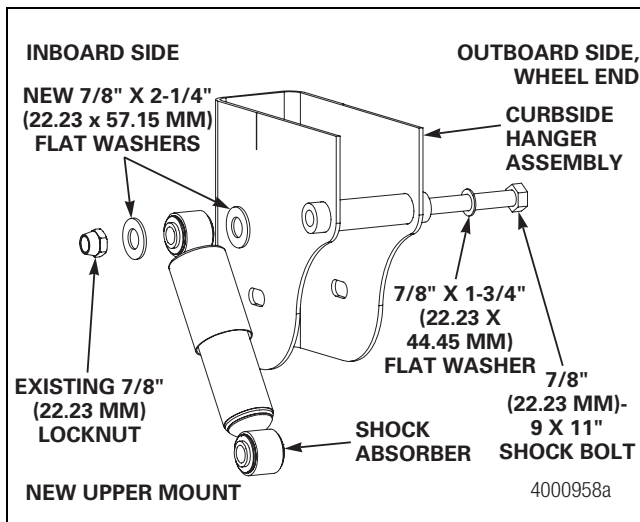

Figure 9.28

5. Remove the 7/8-inch (22.23 mm) nut and 7/8-inch x 1-3/4-inch O.D. (22.23 x 44.45 mm) washer from the LOWER shock absorber mounting. Do not discard this washer. Figure 9.29.

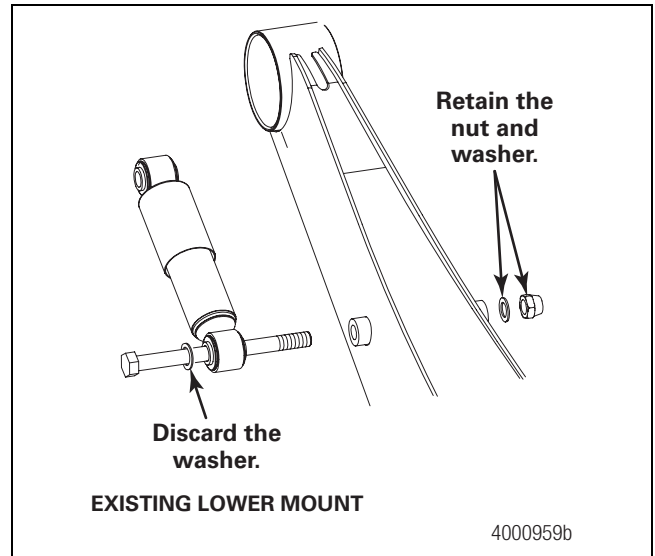

Figure 9.29

6. Remove and discard the 7/8-inch x 1-3/4-inch O.D. (22.23 x 44.45 mm) washer on the shock absorber bolt.
7. Install the new 7/8-inch x 2-1/4-inch O.D. (22.23 x 57.15 mm) washer between the bolt head and shock absorber. Install a new, larger washer between the shock absorber and the shock tube. Figure 9.30.

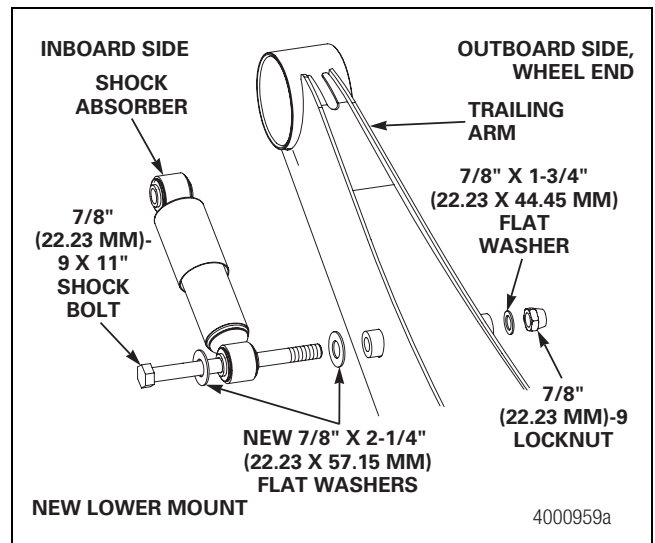



Figure 9.30

8. Install the washer and locknut. Hand-tighten the nut.

9 Suspensions

9. Verify that the suspension is at the correct ride height. Refer to Maintenance Manual 14F, RideStar™ RFS Series Trailer Air Suspension Systems, for ride height instructions.
10. Tighten the nuts at the upper and lower shock absorber mountings to 350-400 lb-ft (465-542 N•m). 

Installing a Replacement Shock Absorber and New 2-1/4-inch O.D. (57.15 mm) Washers

1. Wear safe eye protection.
2. Park the trailer on a level surface. Block the wheels to prevent the trailer from moving. Correctly support the trailer.
3. Remove the 7/8-inch (22.23 mm) nut and 7/8-inch x 1-3/4-inch O.D. (22.23 x 44.45 mm) washer from the UPPER shock absorber mounting. Discard the washer. Figure 9.27.
4. Remove the 7/8-inch (22.23 mm) nut and 7/8-inch x 1-3/4-inch O.D. (22.23 x 44.45 mm) washer from the LOWER shock absorber mounting. Remove the lower bolt and washer from the shock absorber. Discard the washer that's under the bolt head. Figure 9.29.
5. Remove the shock absorber from the upper bolt.
6. Install the new 7/8-inch x 2-1/4-inch O.D. (22.23 x 57.15 mm) washer onto the upper shock absorber bolt between the shock tube and the shock absorber. Install the larger-diameter washer and locknut. Hand-tighten the nut. Figure 9.28.
7. Install the new 7/8-inch x 2-1/4-inch O.D. (22.23 x 57.15 mm) washer onto the lower shock absorber bolt. Install the shock absorber, then the larger washer between the shock absorber and shock tube. Install the washer and locknut. Hand-tighten the nut. Figure 9.30.
8. Verify that the suspension is at the correct ride height. Refer to Maintenance Manual 14F, RideStar™ RFS Series Trailer Air Suspension Systems, for ride height instructions.
9. Tighten the nuts at the upper and lower shock absorber mountings to 350-400 lb-ft (465-542 N•m). 

Important Information

Meritor automatic slack adjusters (ASAs) should not need to be manually adjusted in service. ASAs should not have to be adjusted to correct excessive pushrod stroke. The excessive stroke may be an indication that a problem exists with the foundation brake, ASA, brake actuator or other system components.

Meritor recommends troubleshooting the problem, replacing suspect components and then confirming proper brake operation prior to returning the vehicle into service.

In the event that a manual adjustment must be made (although not a common practice), a service appointment and full foundation brake, ASA, and other system component inspection should be conducted as soon as possible to ensure integrity of the overall brake system.

For Meritor brake adjustment, refer to the brake adjustment tables in this manual. For non-Meritor brake adjusters, refer to the brake manufacturer's service procedures.

Hazard Alert Messages

Read and observe all Warning and Caution hazard alert messages in this publication. They provide information that can help prevent serious personal injury, damage to components, or both.

WARNING

To prevent serious eye injury, always wear safe eye protection when you perform vehicle service or maintenance.

Technical Publications

How to Obtain Additional Maintenance and Service Information

Refer to the publications in Table CH. To obtain these publications, refer to the Service Notes page on the front inside cover of this manual.

Table CH: Publications

| Model | Manual |
|--|---------------------------------|
| Trailer Axles | Maintenance Manual 14 |
| Trailer Axles with Unitized Wheel Ends | MM-0420 |
| Meritor Tire Inflation Systems | Maintenance Manual 14P |
| Trailer Axles | Failure Analysis Manual TP-0445 |

Description

Axle Models

Meritor trailer axle models fall into three categories.

- Conventional axles currently in production, such as TN, TP, TQ, TR, TQC, TQD and TRD models. These axle models are available either for installation on new trailers or as service replacement parts.
- Conventional axles no longer in production, such as TK, TKN, RN and RQ models. These axle models are available only as service replacement parts.
- TB Series axles with unitized wheel-end assemblies. These axles provide a low-maintenance alternative to conventional wheel ends.

Axle Designs

Beams

Straight beams, such as the TN, TP, TQ and TR models. Figure 10.1.

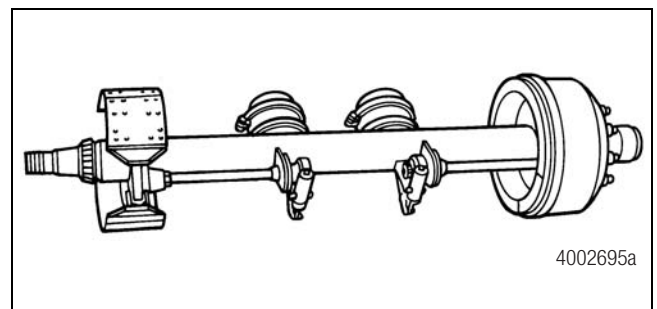

Figure 10.1

Crank beams, such as the TQC model. Figure 10.2.

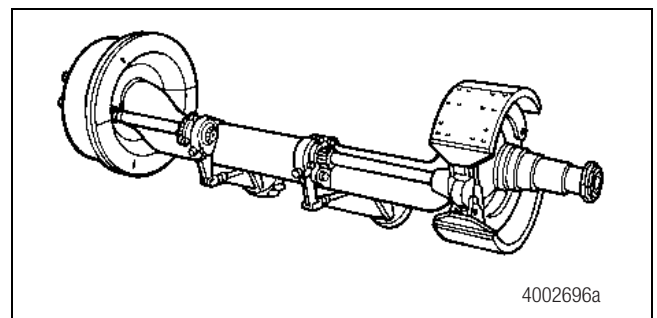

Figure 10.2

10 Trailer Axles

Drop center beams, such as the TQD and TRD models. Figure 10.3.

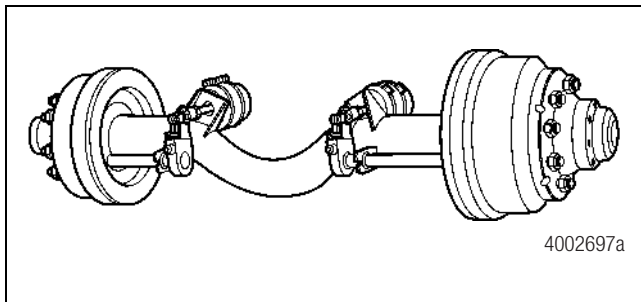

Figure 10.3

Beam Cross Sections

- Round
- Rectangular (available only as service replacement beams)

Spindle Designs

- The TN/TQ Series axles use the most common wheel bearings in the trailer industry.
- The TR Series axles use wheel bearings compatible with drive axles.
- The TP Series axles use bearings compatible with Fruehauf axles.
- The TB Series axles use unitized bearings.

Brakes

- Q and Q Plus™ brakes
- Stopmaster® wedge brakes
- Dura-Master® and DiscPlus™ air disc brakes

TB Series Trailer Axles with Unitized Wheel-End Assemblies

⚠ CAUTION

TB series trailer axles with unitized wheel-end assemblies use conventional brakes and automatic slack adjusters, as well as conventional tire and wheel assemblies. Service these components as you would under normal operating conditions to avoid damage to components.

A unitized wheel end is permanently sealed and lubricated as an assembly. Do not attempt to remove the hub bearings, seals and lubricant. You cannot service these components. Damage to components can result.

NOTE: Removal of the long-life bearings, seals and lubricant from the hub assembly will void the warranty.

The TB series trailer axle features a permanently-sealed and lubricated unitized wheel-end assembly designed to help reduce wheel-end maintenance.

The unitized wheel end is designed to remain in place on the axle for a minimum of five years or 500,000 miles (800 000 km).

For TB series unitized wheel-end service procedures, refer to Maintenance Manual MM-0420, Trailer Axles with Unitized Wheel Ends. To obtain this publication, refer to the Service Notes page on the front inside cover of this manual.

Unitized Wheel Ends and Conventional Wheel Ends

On a unitized wheel end, you install the hub, seal, lubricant and bearings onto the axle spindle as an assembly. Figure 10.4.

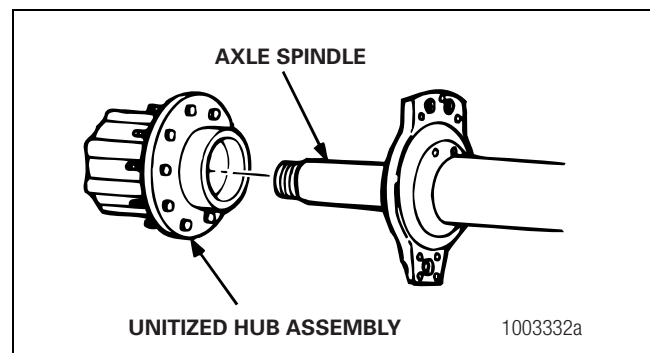

Figure 10.4

On a conventional wheel end, you install the hub, seal, lubricant and bearings onto the axle spindle as separate components. Figure 10.5.

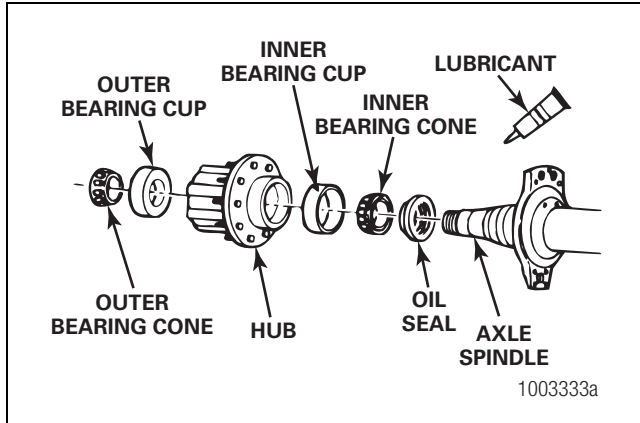

Figure 10.5

How to Identify Trailer Axles with Unitized Wheel Ends

Removal of long-life bearings, seals or lubricant from the Meritor TB series trailer axle hub will void the warranty. Refer to Maintenance Manual MM-0420, Trailer Axles with Unitized Wheel Ends, or call ArvinMeritor's Customer Service Center at 800-535-5560 for information.

- The model number designation for the TB series is prefixed with TB; for example, TB-4670 or TB-8670.
- The axle spindles are shorter with a single journal.
- The hubs contain non-serviceable bearings, seals and lubricant.
- The hubcaps screw onto the axle spindle and have no provisions for adding lubricant.
- The axle spindle retention hardware features a thicker inner nut and a bendable tab lock washer.
- Warranty information is stamped on each unitized wheel-end hubcap.

How to Find the Model Number, Serial Number and Date of Manufacture

Effective July 2004, Meritor now engraves the axle model number, serial number and date of manufacture onto the center of the trailer axle beam. Figure 10.6. Previously Meritor affixed an aluminum tag to the center of the axle beam that includes this information. Figure 10.7.

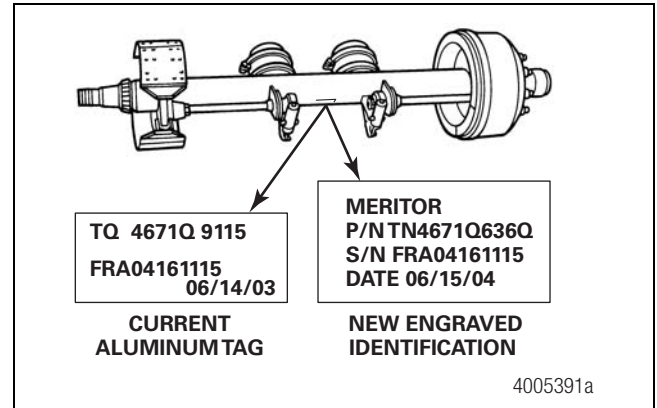

Figure 10.6

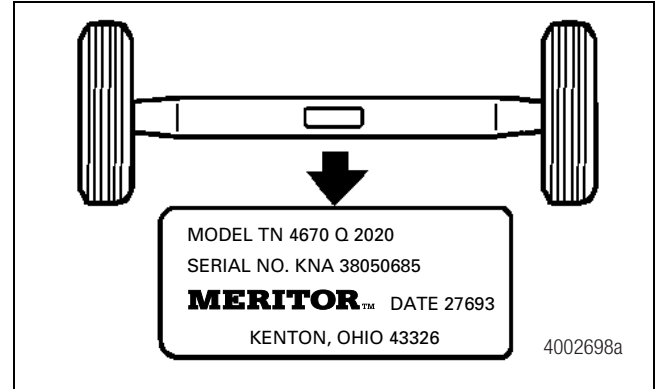

Figure 10.7

10 Trailer Axles

What the Numbers Mean

Model Number

The model number contains letters and digits (for example, TN 4670 Q 2020); and identifies the axle assembly. You'll need the model number to obtain replacement parts.

Also refer to the Current Product Model Numbers chart in this section and Figure 10.7.

Serial Number

The serial number is a Meritor internal control number; for example, KNA 38050685.

Date of Manufacture

The date of manufacture is a Julian date; for example, 27693.

- The first three digits (276) indicate the 276th day of the year: October 3.
- The last two digits (93) indicate the year: 1993.

Model Nomenclature

Current Production Model Numbers

Model numbers for Meritor trailer axles are composed of letters and digits; for example, TQD 4670 Q 52. These letters and digits indicate the weight capacity and type of components installed on the axle. For a more comprehensive list of Meritor current production trailer axle models, refer to publication TP-8301, Trailer Axle Specifications.

Meritor aftermarket model numbers differ from the current production model numbers detailed in Figure 10.8. Refer to parts catalog PB-8857, Brake, Trailer Axle and Wheel-Attaching Parts, for a chart detailing these numbers. To obtain these publications, refer to the Service Notes page on the front inside cover of this manual.

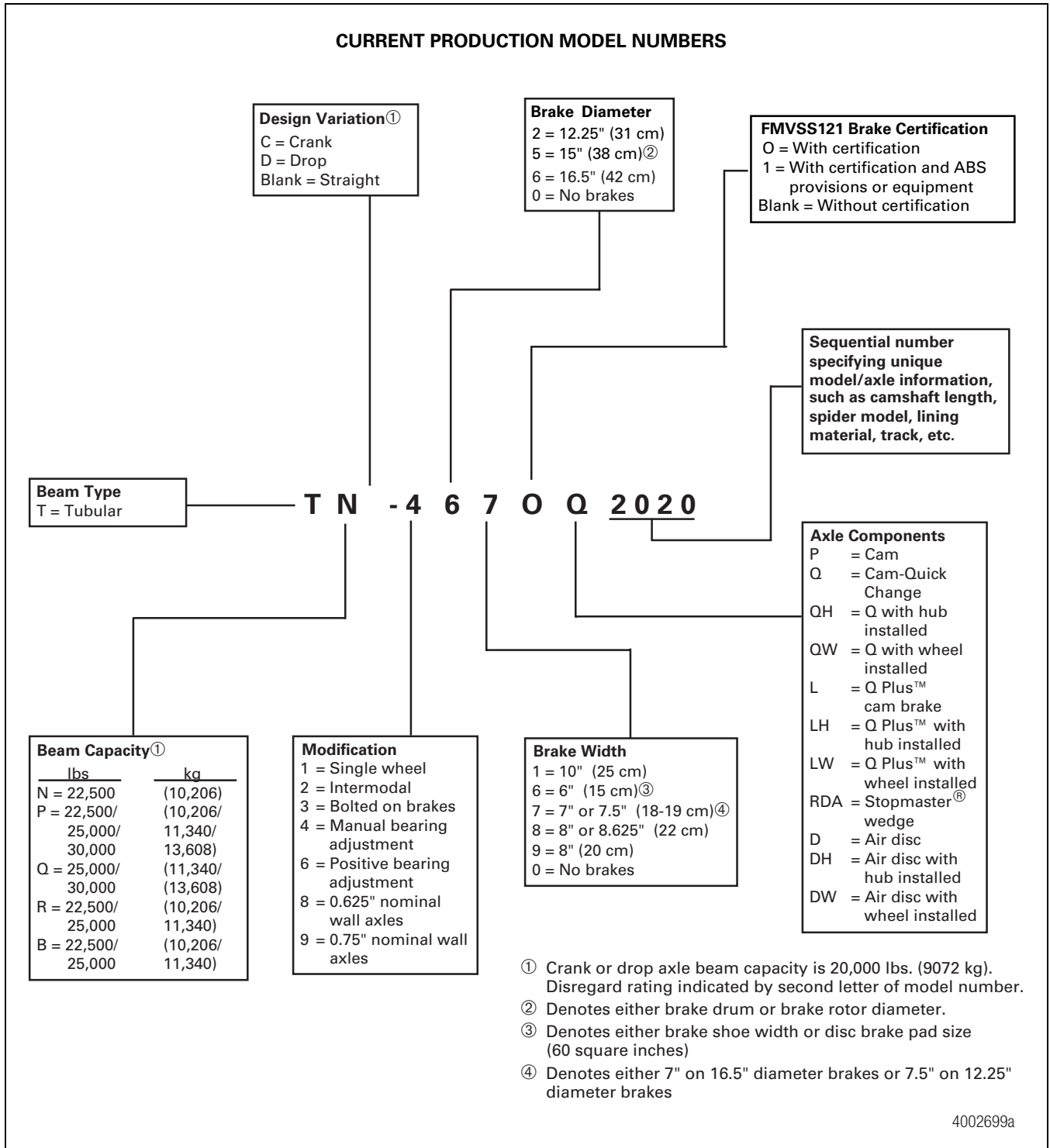

Figure 10.8

11 Transfer Cases

Hazard Alert Messages

Read and observe all Warning and Caution hazard alert messages in this publication. They provide information that can help prevent serious personal injury, damage to components, or both.

⚠ WARNING

To prevent serious eye injury, always wear safe eye protection when you perform vehicle maintenance or service.

Park the vehicle on a level surface. Block the wheels to prevent the vehicle from moving. Support the vehicle with safety stands. Do not work under a vehicle supported only by jacks. Jacks can slip and fall over. Serious personal injury and damage to components can result.

Technical Publications

How to Obtain Additional Maintenance and Service Information

Refer to the publications in Table CI. To obtain these publications, refer to the Service Notes page on the front inside cover of this manual.

Table CI: Publications

| Model | Maintenance Manual |
|---|-----------------------------|
| MTC-4208, -4210 and -4213 Transfer Cases | Maintenance Manual MM-0146 |
| T-2119 Series Transfer Cases | Maintenance Manual MM-01125 |
| Three-Shaft Design Transfer Cases | Maintenance Manual 3 |
| T-223 Series "Clover Leaf" Four-Shaft Design Transfer Cases | Maintenance Manual 3A |
| T-215 Series Transfer Cases | Maintenance Manual 3B |
| T-228 Series Transfer Cases | Maintenance Manual 3C |
| T-2111 Series Transfer Cases | Maintenance Manual 3D |
| T-2120RS Two-Shaft, Single-Speed Transfer Cases | Maintenance Manual 3E |
| TG-2213 Two-Shaft, Two-Speed Transfer Cases | Maintenance Manual 3G |
| Operating Meritor's TG-2213RD Transfer Case | Operator Manual TP-98143 |

Description

Meritor offers a variety of transfer cases constructed to meet a wide range of output shaft requirements. Design features include 4x4 or 6x6 capability, selected gear ratios, declutch, proportional differential, auxiliary drive, parking brake, and two-, three- or four-shaft designs.

Identification

An identification tag is located on the front cover. Figure 11.1.

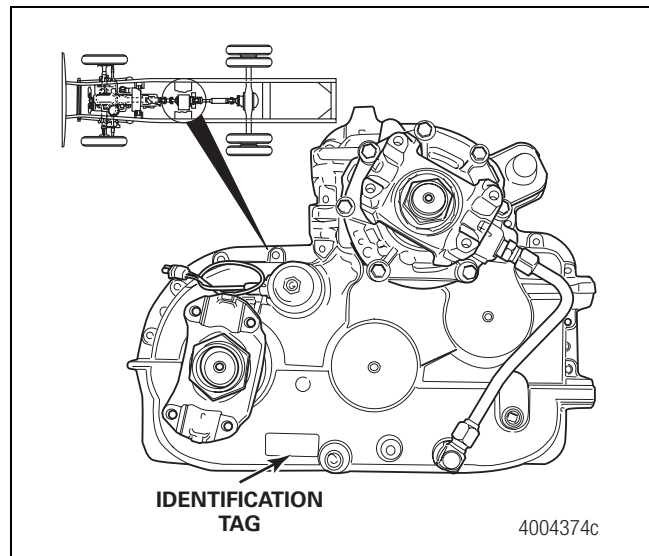

Figure 11.1

Model Nomenclature

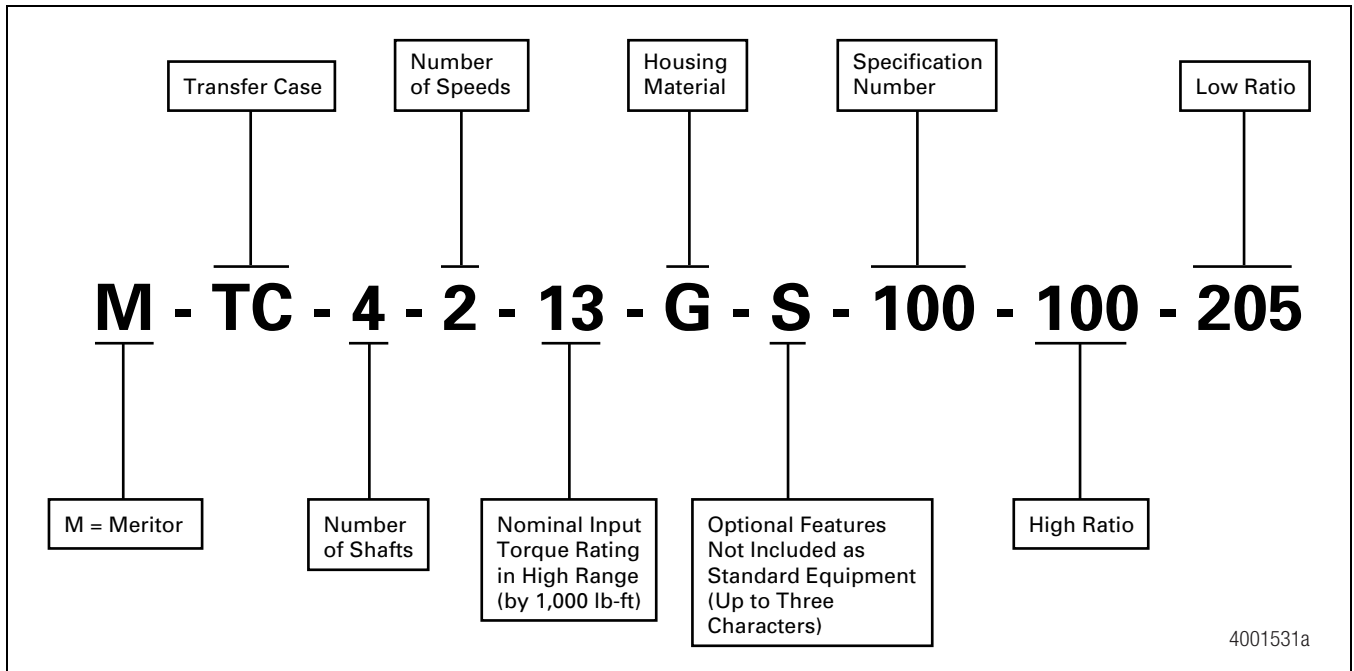

Figure 11.2

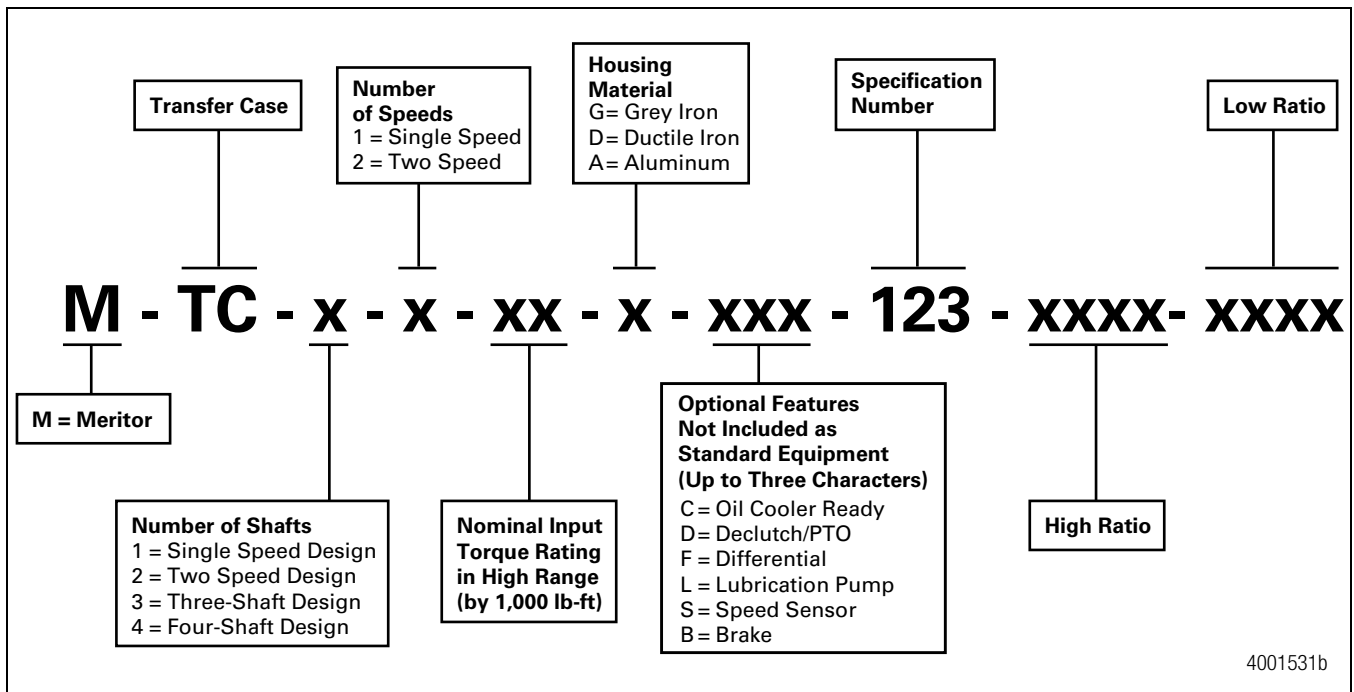

Figure 11.3

11 Transfer Cases

Lubricant Temperatures

Meritor MTC-4208, MTC-4209 and MTC-4210 Series Transfer Cases

CAUTION

Meritor MTC-4208, MTC-4209 and MTC-4210 Series transfer cases may operate with an oil temperature above 300°F (148°C). However, if the oil temperature reaches 350°F (177°C), stop the vehicle immediately. Check for the cause of overheating to prevent damage to components.

Meritor MTC-4208, MTC-4209 and MTC-4210 Series transfer cases may operate with an oil temperature above 300°F (148°C). However, if the oil temperature reaches 350°F (177°C), stop the vehicle immediately and check for the cause of overheating. Oil temperatures at this range should only occur in linehaul or utility applications that operate under high speed for long periods of time.

Refer to Maintenance Manual MM-0146, MTC-4208, -4210 and -4213 Series Transfer Cases.

Other Meritor Transfer Cases

CAUTION

Most Meritor transfer cases can operate above 190°F (88°C) without damage. However, if the oil temperature reaches 250°F (121°C) for non-synthetic oil or 275°F (135°C) for synthetic oil, stop the vehicle immediately and check for the cause of overheating. The maximum continuous running oil temperature should not exceed 225°F (107°C) for non-synthetic oil or 250°F (121°C) for synthetic oil. Damage to components can result.

Many Meritor transfer cases and axles have a tapped hole in the housing for the installation of an oil temperature indicator, which helps to prevent damage to components that can occur if the oil temperature is too high.

A high oil temperature lowers oil viscosity levels, which can result in reduced oil-film thickness between metal parts. If you operate equipment with this condition over extended periods of time, damage to components can result.

Do Not Install API GL-5 Oils

CAUTION

Meritor does not approve petroleum-based and multiviscosity oil. Do not install API GL-5 oils, which contain extreme-pressure (EP) additives. These additives can form sludge at normal operating temperatures. Damage to components can result. Use only SAE Grade 50W synthetic oil in the transfer case.

Do not install API GL-5 oils in a transfer case. This specification contains extreme pressure (EP) additives that can form sludge at normal operating temperatures and damage transfer case components.

Inspection

Magnets and Magnetic Drain Plugs

Most Meritor transfer cases are equipped with magnetic drain plugs with a minimum pick-up capacity of 20 ounces (0.57 kg) of low carbon steel. Replace the magnetic drain plug each time you change the oil. Use the correct part. If you use a pipe plug instead of a drain plug, the pipe plug will leak.

You can reuse a drain plug you removed if it has a minimum pick-up capacity of 20 ounces (0.57 kg) of low carbon steel after you clean it.

Visually inspect the Meritor MTC-4208, -4210 and -4213 transfer cases daily for any leaks. The oil level should be inspected every 1,000 miles (1069 km), 100 hours or every month, whichever comes first. In addition, the transfer case should be inspected for leaks and the correct oil level before and after extended time high speed road trips. Inspect the following areas.

- Cooler lines and fittings
- Seals
- Breather
- Fill and drain plugs
- Pump inlet tube and fittings
- Gaskets and shims
- During the inspection visually check to ensure the transfer case oil level is to the bottom of the oil fill hole.

Operating Information

Breather

CAUTION

Cover the breather when steam cleaning the housing. If the breather is not covered, water can enter the housing and contaminate the oil.

The breather releases pressure that builds up inside the transfer case during vehicle operation.

Seals

CAUTION

Always use the correct tools and procedures when you replace a seal. A seal that is not correctly installed can leak. Damage to components can result.

Some Meritor transfer cases use unitized seals, and some transfer cases use single seals or two-piece seals. You must install the correct seal when you service a transfer case. Otherwise, you can damage the seal and cause it to leak.

Seals keep lubricant in and dirt out of a component. When they are worn or damaged, seals leak and produce low lubricant levels which may damage components. Always replace unitized seals after yokes have been removed.

Some Meritor transfer cases use unitized seals, and some transfer cases use single seals or two-piece seals. You must install the correct seal when you service a transfer case. Otherwise, you can damage the seal and cause it to leak. Refer to the appropriate transfer case parts catalog for the correct seal part number before you install a seal.

Check and Adjust the Oil Level



CAUTION

Only use new lubricant when you change or adjust the oil in the transfer case. Do not reuse lubricant, which can contain metallic particles and other contaminants. Damage to components can result.

Meritor does not approve petroleum-based and multiviscosity oil. Do not install API GL-5 oils, which contain extreme-pressure (EP) additives. These additives can form sludge at normal operating temperatures. Damage to components can result. Use only SAE Grade 50W synthetic oil in the transfer case.

Do not operate the transfer case if the oil level is below the bottom of the fill hole, which may be an indication that the transfer case is leaking. Damage to components can result. If the transfer case is leaking, repair the leak. Adjust the oil level before returning the transfer case to service.

When servicing the transfer case, add the specified lubricant until the oil level is even with the fill hole. Do not overfill the transfer case, which can cause the transfer case to overheat. Damage to components can result.

1. Park the vehicle on a level surface. Block the wheels to prevent the vehicle from moving.
2. Clean the area around the fill plug. Remove the fill plug from the transfer case. Figure 11.4. The oil level must be even with the bottom of the fill plug hole.
 - **If oil flows from the hole when you loosen the plug:** The oil level is high. Drain the oil to the bottom of the fill hole.
 - **If the oil level is below the bottom of the fill plug hole or stand pipe:** Add the specified oil into the transfer case until the oil is even with the bottom of the fill hole.
3. Install and tighten the fill plug to 35-50 lb-ft (47-68 N•m). 
4. Test drive the vehicle for at least one mile (1.6 km). Allow the oil to settle for five minutes and recheck the fluid level. Top off the oil level by adding oil to the fill opening. Reinstall and tighten the fill plug to 35-50 lb-ft (47-68 N•m). 

11 Transfer Cases

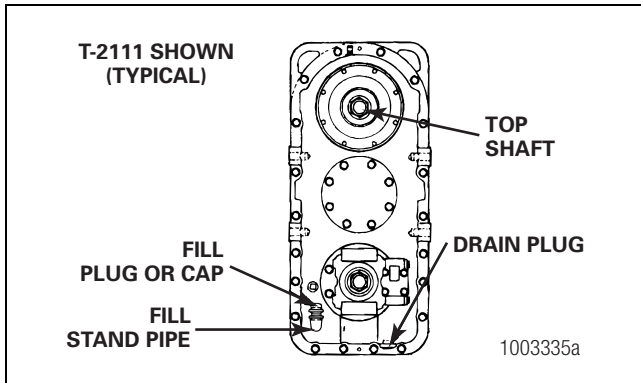

Figure 11.4

Drain and Replace the Oil

Transfer Case Oil

⚠ CAUTION

Only use new lubricant when changing or adjusting the oil in the transfer case. Do not reuse lubricants which can contain metallic particles and other contaminants. Damage to components can result.

1. Park the vehicle on a level surface. Block the wheels to prevent the vehicle from moving. Place a large container under the transfer case.
2. Remove the magnetic drain plug from the bottom of the transfer case. Drain and discard the oil correctly. Clean the plug.
3. Install and tighten the drain plug to 35-50 lb-ft (47-69 N•m). Clean the area around the fill plug. Remove the fill plug from the transfer case. **ⓘ**
4. Add the specified oil into the transfer case until the oil level is even with the bottom of the fill plug hole. Install and tighten the fill plug to 35-50 lb-ft (47-68 N•m). **ⓘ**
5. Test drive the vehicle for 1/4 mile (0.4 km). Allow the oil to settle for five minutes and recheck the fluid level. Top off the oil level by adding oil to the fill opening. Reinstall and tighten the fill plug to 35-50 lb-ft (47-68 N•m). **ⓘ**

Intervals

| Operation | Frequency |
|-----------------------|--|
| Inspect for oil leaks | Daily |
| Check oil level | 1,000 miles (1609 km), 100 hours or every month, whichever occurs first |
| Check oil level | Before and after extended time high speed road trips |
| Initial oil change | 2,500 miles (4000 km) or 125 hours, whichever occurs first |
| Synthetic oil change | Every 25,000 miles (40 000 km), 1,250 hours or every 12 months, whichever occurs first |

Towing Procedures

⚠ CAUTION

Follow towing procedures recommended by Meritor to prevent internal damage to the transfer case.

Meritor recommends that you use one of the two methods below when towing a vehicle equipped with an MTC-4208, -4210 or -4213 transfer case to prevent damage to the transfer case.

For complete towing information and instructions on shaft removal, refer to Technical Bulletin TP-9579.

Method 1

Remove both axle shafts from the axles that will remain on the road when the vehicle is transported.

Method 2

Remove the drive shafts from axles that contact the ground.

Specifications

Table CJ: Transfer Case Oil Specifications*

| Oil Description | Meritor Specification | A.P.I. Specification | Military Specification | SAE Grade | Outside Temperature |
|---|------------------------------|--------------------------------------|------------------------|-------------|---|
| Petroleum GL-1 Oil with Rust and Oxidation Inhibitor ¹ | — | A.P.I. GL-1 | — | 90W 80W | Above 10°F (–12°C) Above –15°F (–26°C) |
| Heavy-Duty Engine Oil ¹ | — | A.P.I.-CD, CE, SF or SG ² | — | 50W 40W 30W | Above 10°F (–12°C) Above –12°F (–26°C) |
| Full-Synthetic Oil ³ | 081 | — | — | 50W | Above –40°F (–40°C) |
| A.P.I. GL-5 (Axle Lube) ⁴ | DO NOT USE IN TRANSFER CASES | | | | |

¹ 90W GL-1 or 50W motor oil is the same viscosity and commonly used above 10°F (–12°C).

² Current designations are acceptable.

³ Meritor-approved full-synthetic oil for manual Meritor transmissions is also approved for Meritor transfer cases. Use synthetic oil only if the transfer case was initially filled with synthetic oil.

⁴ Do not use multi-viscosity (i.e., 80/90W) GL-5 gear oil, axle lube.

* Do not use multi-viscosity (i.e., 80/90W) GL-5 gear oil, axle lube. Do not mix or switch oil types. Use the same oil that initially filled the transfer case. Do not use multi-viscosity oils.

Capacities

Table CK: Transfer Case Oil Capacities

| Transfer Case Model | Approved Oils | Oil Capacity | | Transfer Case Model | Approved Oils | Oil Capacity | |
|---------------------|-------------------------------|-----------------------|---------|---------------------|-----------------------|-----------------------|---------|
| | | Pints* ^{1,2} | Liters* | | | Pints* ^{1,2} | Liters* |
| T-32 | Petroleum or 50W Synthetic | 2.0 | 0.95 | TG-2213 | 50W Synthetic Only | 6.5 | 3.10 |
| T-136 | | 14.0 | 6.62 | T-2119 | | 7.0 | 3.30 |
| T-215 | | 3.0 | 1.42 | MTC-4208 | 9.0 | 4.30 | |
| T-221 | | 4.0 | 1.89 | MTC-4210 | 9.0 | 4.30 | |
| T-223 | | 5.0 | 2.37 | MTC-4213 | 9.0 | 4.30 | |
| T-226 | | 6.5 | 3.07 | | | | |
| T-228 | | 21.0 | 9.93 | | | | |
| T-232 | | 6.2 | 2.93 | | | | |
| T-1138 | | 13.5 | 6.38 | | | | |
| T-2111 | | 3.0 | 1.42 | | | | |
| T-2111-HD | | 5.0 | 2.37 | | | | |
| T-2111-HT | | 5.0 | 2.37 | | | | |
| T-2111-PD | | 10.0 | 4.73 | | | | |
| T-2111-SD | | 5.0 | 2.37 | | | | |
| T-2120 | | 4.0 | 1.89 | | | | |
| T-2120-RS | | 6.5 | 3.10 | | | | |
| T-600 | 6.2 | 2.93 | | | | | |

¹ Due to the varied transfer case configurations, these fill quantities are for reference only.

² Oil Cooler equipped vehicles will use additional oil to compensate for the cooler and cooler lines.

Refer to bulletin TP-90114, Transmission Lubricant Specifications, for a list of approved distributors of synthetic oil. To obtain this publication, refer to the Service Notes page on the front inside cover of this manual.

Troubleshooting

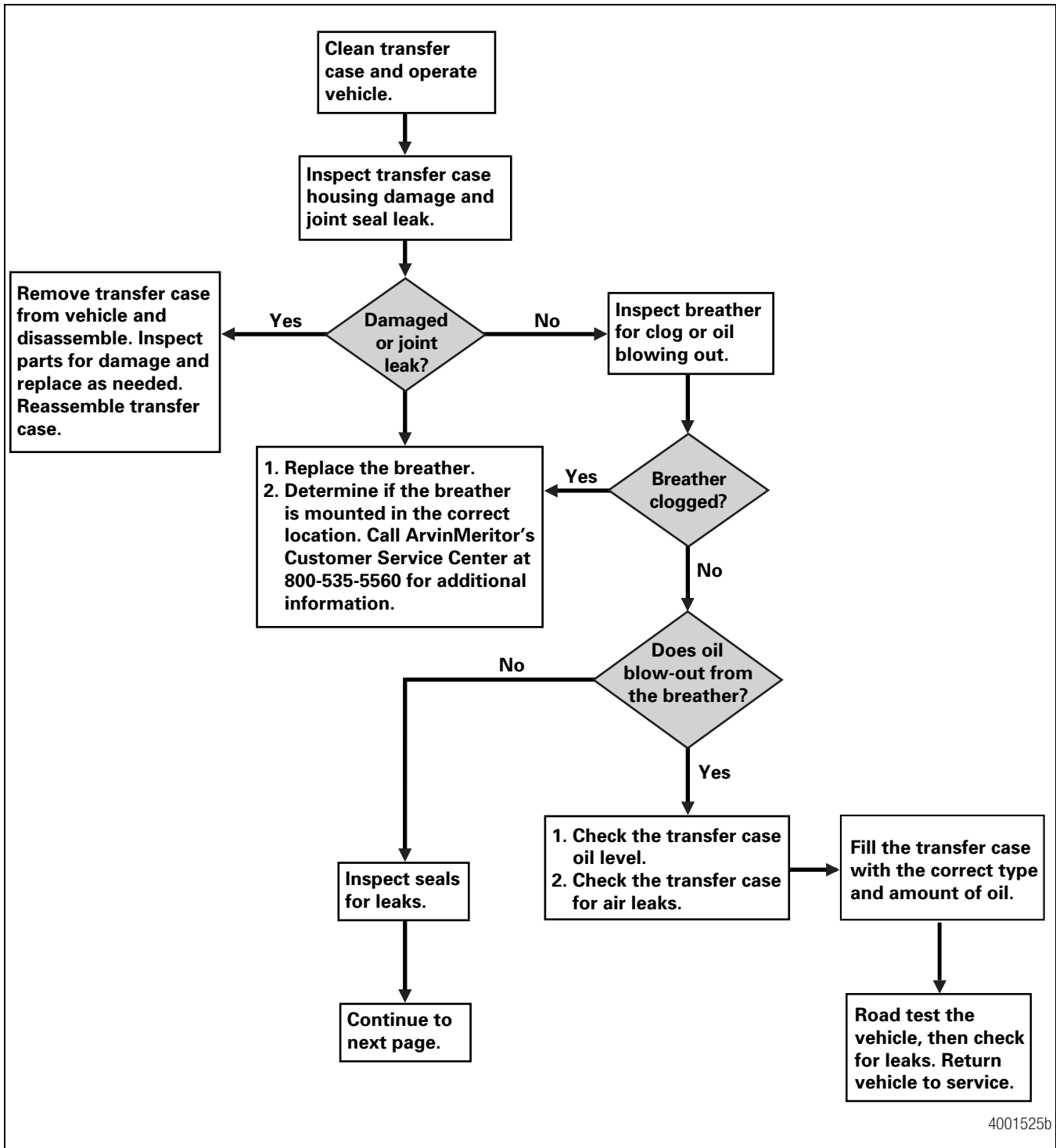

4001525b

Figure 11.5

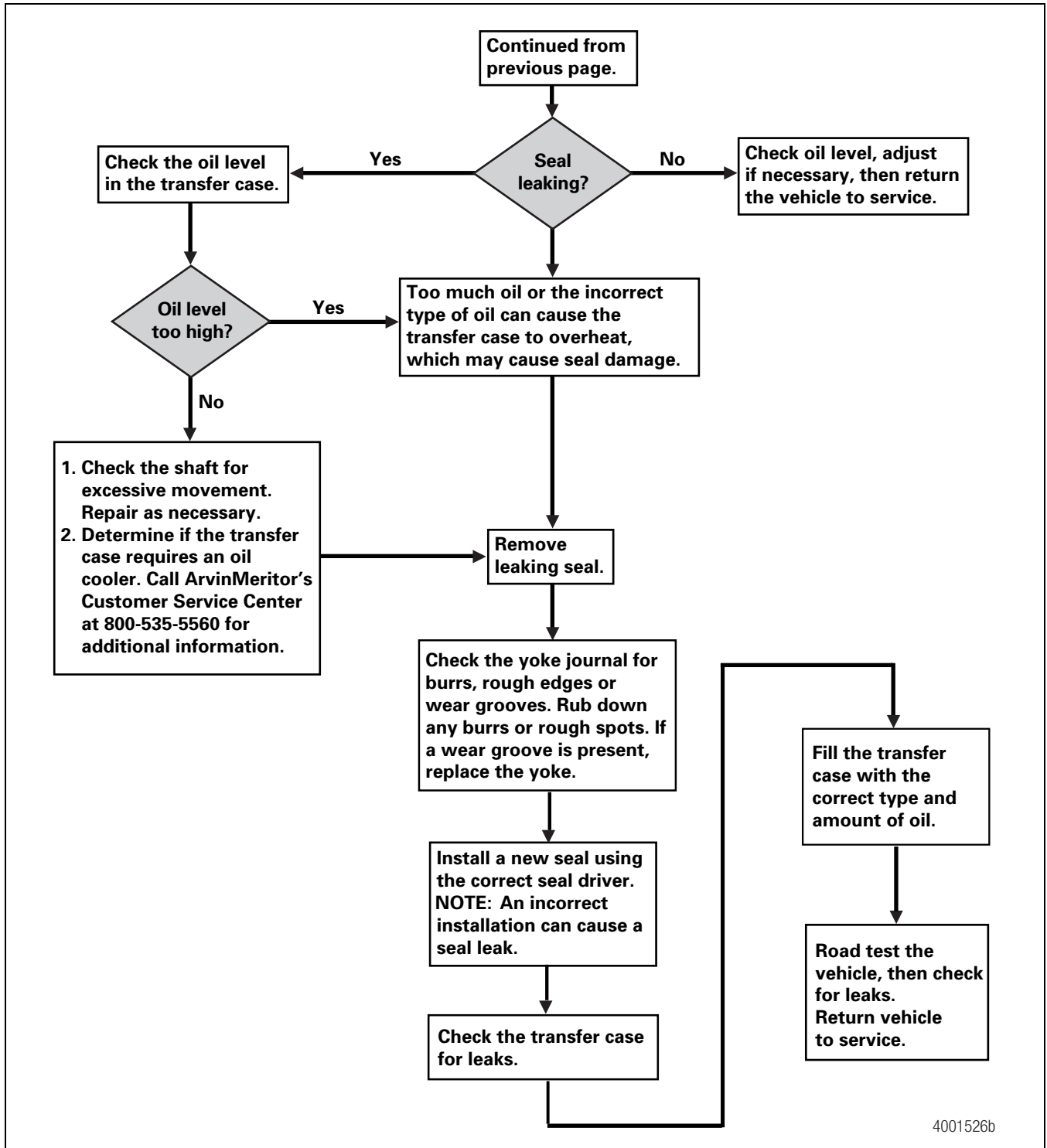

4001526b

Figure 11.6

11 Transfer Cases

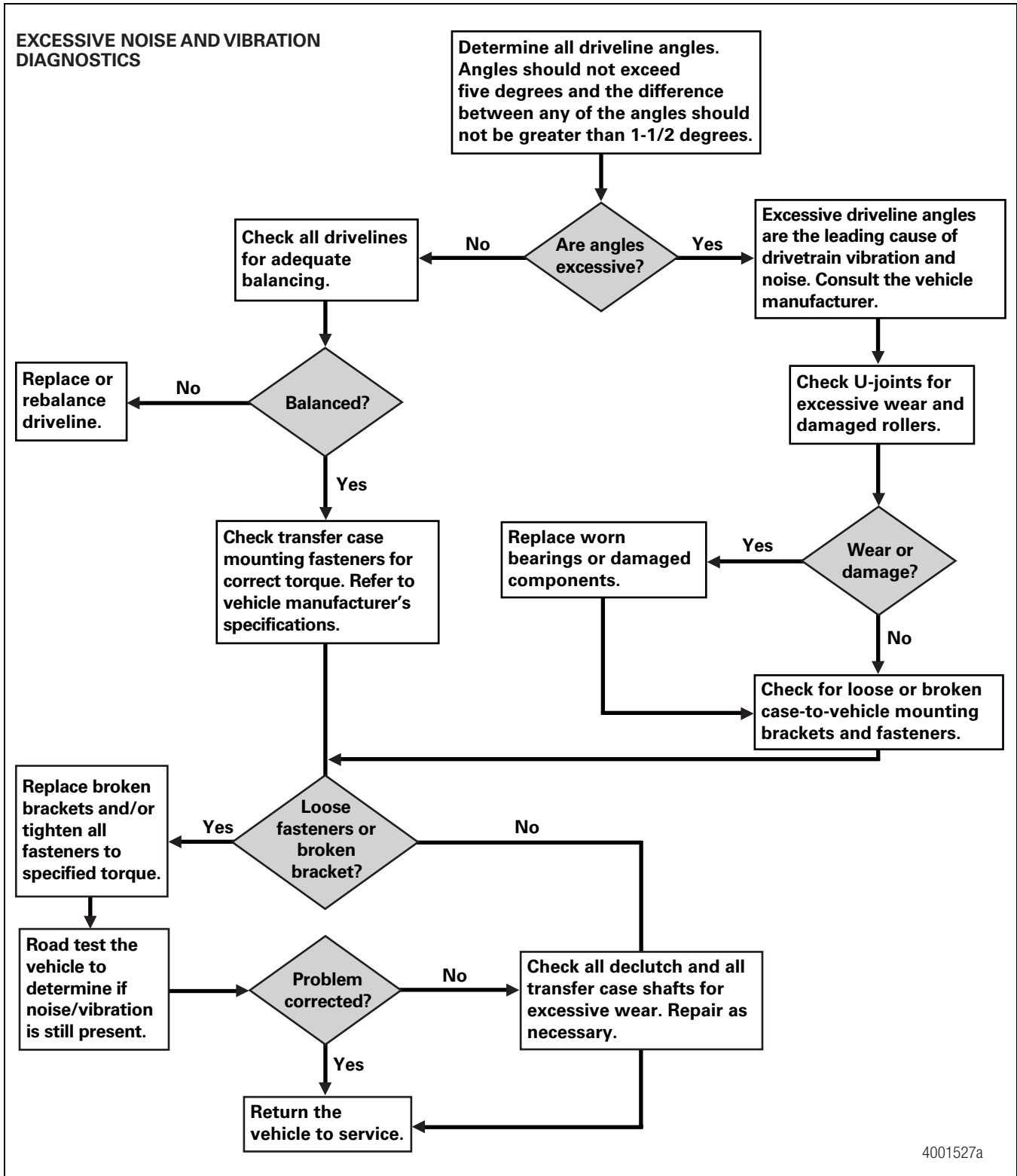
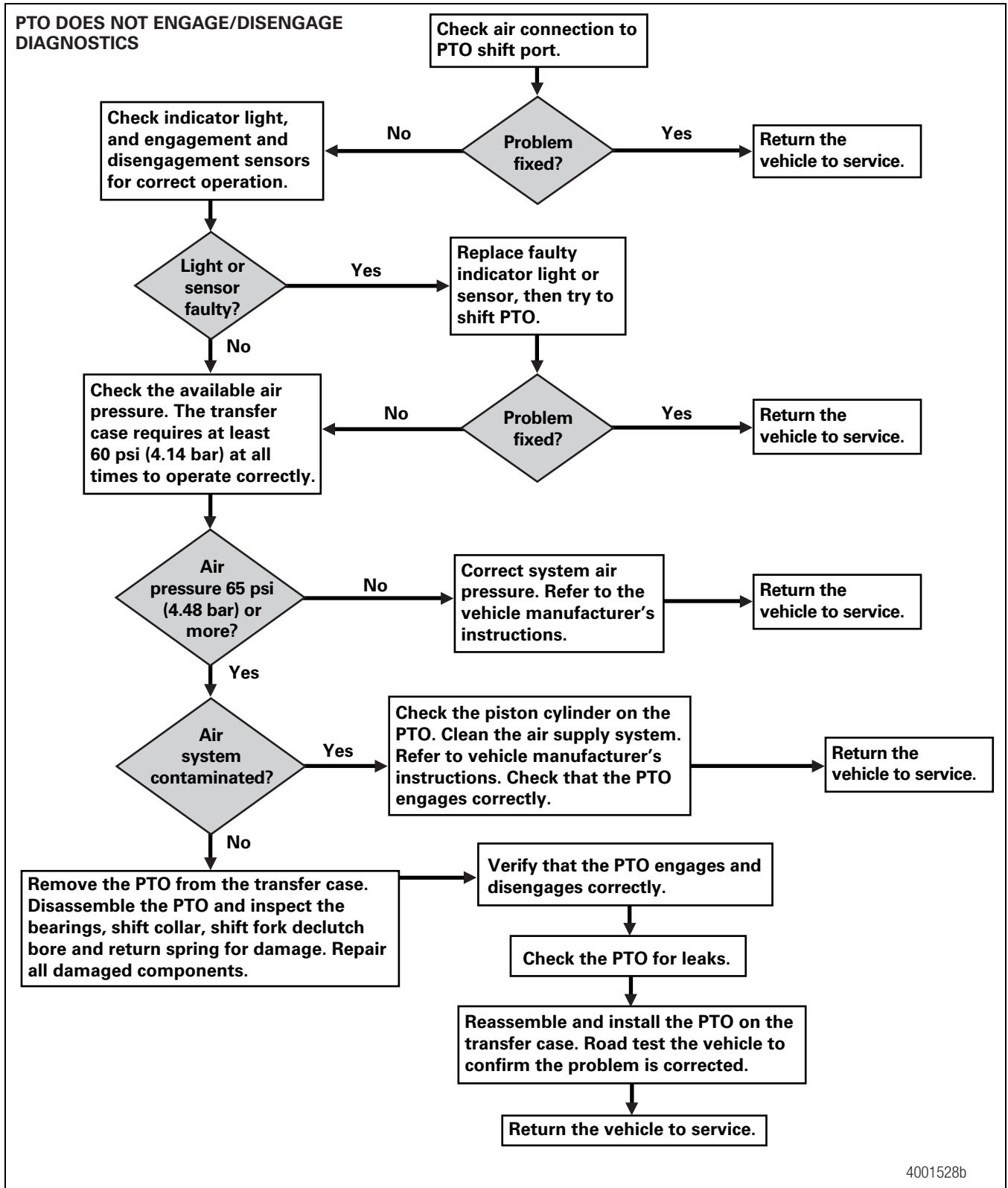

Figure 11.7



4001528b

Figure 11.8

11 Transfer Cases

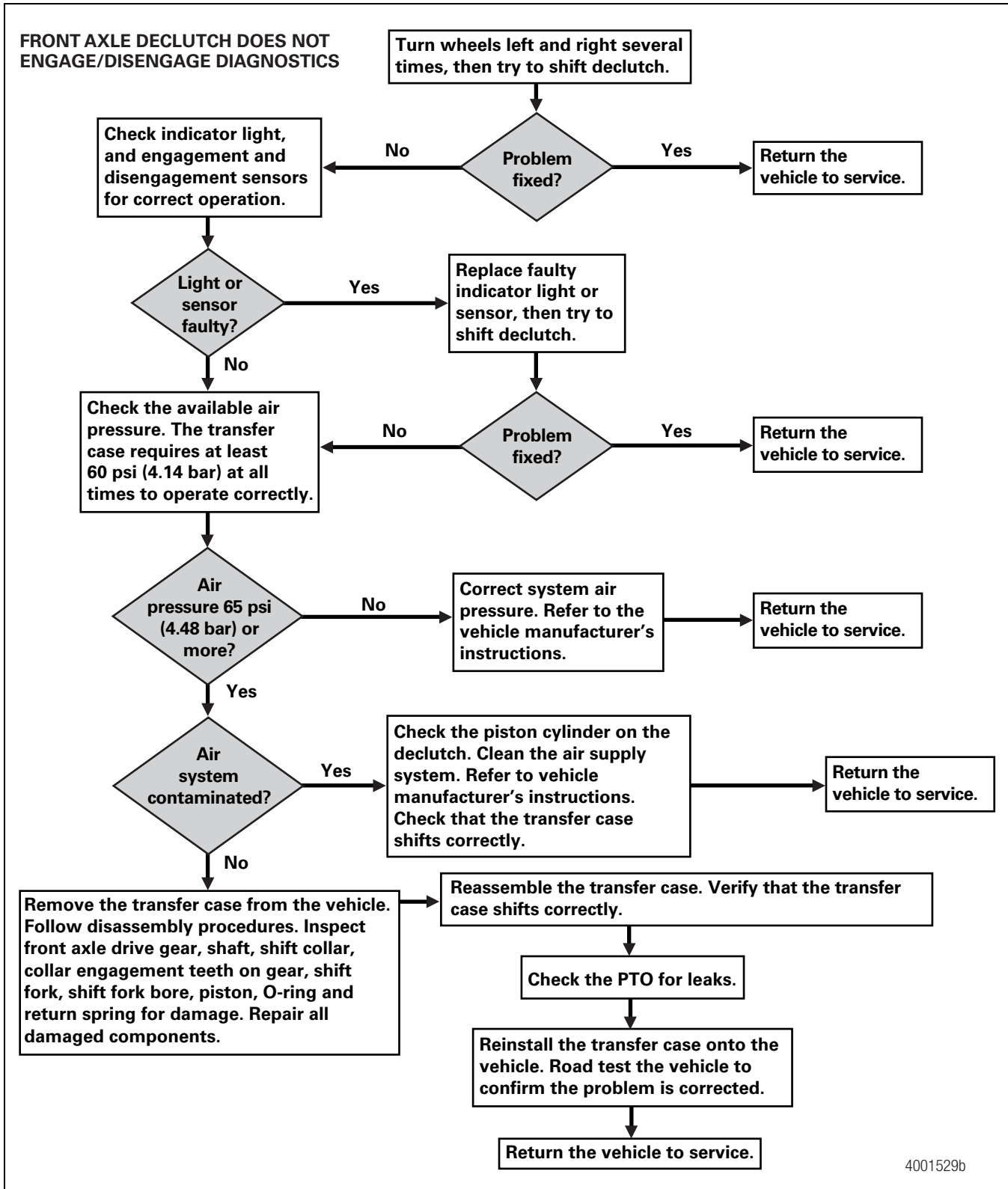

4001529b

Figure 11.9

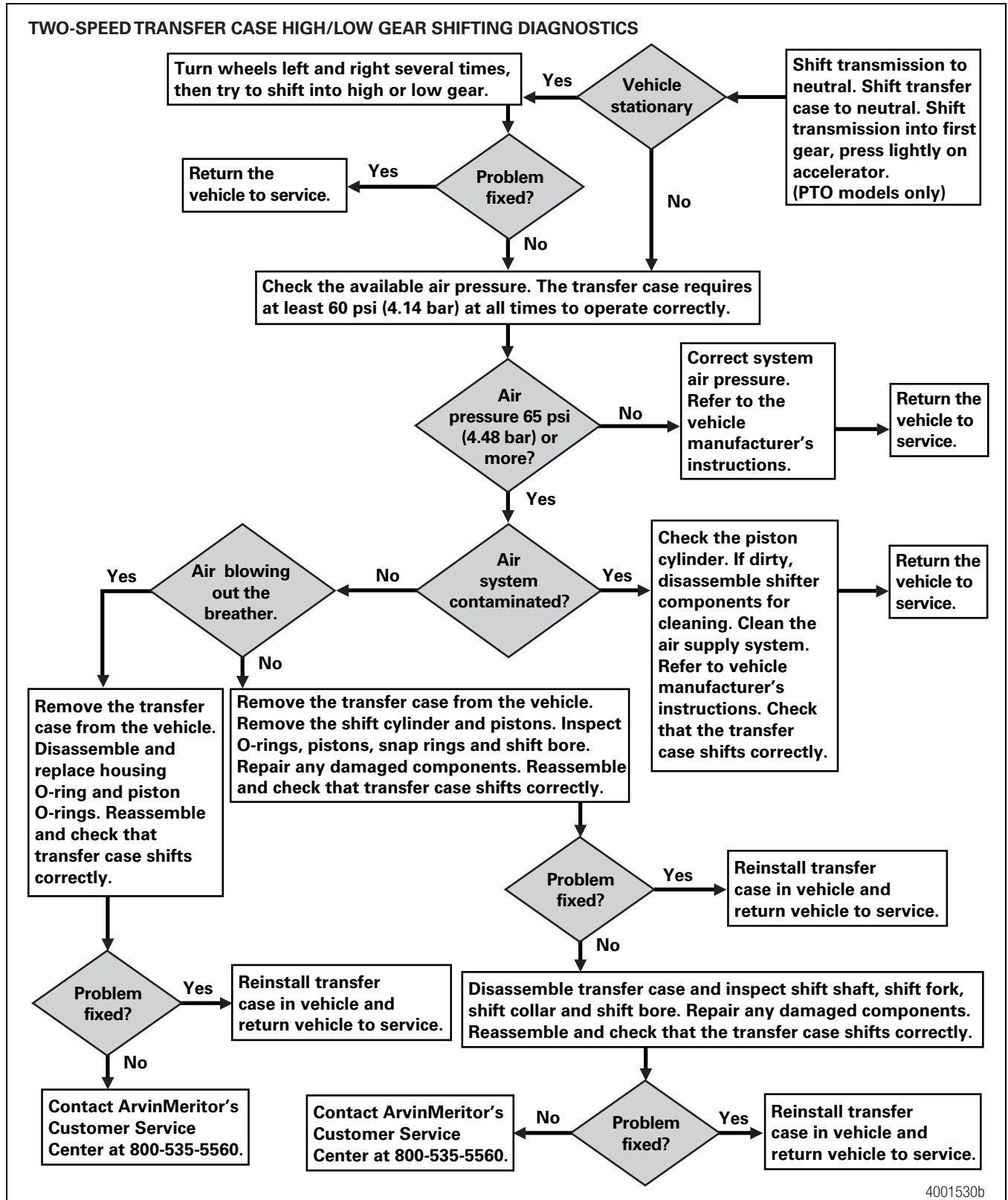

Figure 11.10

4001530b

12 Transmissions

Hazard Alert Messages

Read and observe all Warning and Caution hazard alert messages in this publication. They provide information that can help prevent serious personal injury, damage to components, or both.

WARNING

To prevent serious eye injury, always wear safe eye protection when you perform vehicle maintenance or service.

Technical Publications

How to Obtain Additional Maintenance and Service Information

Refer to the publications in Table CL. To obtain these publications, refer to the Service Notes page on the front inside cover of this manual.

Table CL: Publications

| Model | Manual |
|---|--|
| ZF-FreedomLine Transmissions | Maintenance and Diagnostics Manual MM-0150 |
| ZF-FreedomLine Transmission Wiring Diagram and Fault Code Diagnostics | Publication TP-01110 |
| SureShift™ Transmission | Maintenance and Diagnostics Manual MM-9970 |
| SureShift™ Transmission Wiring Diagram and Fault Code Diagnostics | Publication TP-98114 |
| SureShift™ Transmission Operator Manual | Publication TP-99146 |
| Platform "G" 9- and 10-Speed Transmissions | Maintenance Manual MM-99106 |
| 9-, 10- and 13-Speed Transmissions | Maintenance Manual 26A |
| 9- and 10-Speed Transmissions Operator Manual | Publication TP-8989 |
| 13-Speed Manual Transmission Operator Manual | Publication TP-90192 |
| Air Shift Systems/9-Speed Manual Transmissions | Maintenance Manual 26B |

| Model | Manual |
|--|---|
| 9- and 10-Speed Transmissions Operator Manual | Publication TP-8989 |
| 13-Speed Manual Transmission Operator Manual | Publication TP-90192 |
| Air Shift Systems/9-Speed Manual Transmissions | Maintenance Manual 26B |
| Air Shift Systems/13-Speed Manual Transmissions | Maintenance Manual 26D |
| Electric Over Air (EOA) Range Shift System: All Meritor 9- and 10-Speed Transmissions | Maintenance and Diagnostics Manual MM-99140 |
| Engine Synchro Shift™ (ESS™) Transmission with Meritor's Transmission Control Unit (TCU) | Maintenance and Diagnostics Manual MM-9850 |
| Engine Syncro Shift™ (ESS™) Transmission with Detroit Diesel Corporation's Electronic Control Module (ECM) | Maintenance and Diagnostics Manual MM-96152 |
| Engine Synchro Shift™ (ESS™) Operator Manual | Publication TP-95130 |
| Transmissions | Failure Analysis Manual TP-0445 |

Description

Meritor offers both manual and automated transmissions for the heavy-duty trucking industry. Manual transmissions are available in 9, 10 and 13 speeds. Automated SureShift™ transmissions are available in 9 and 10 speeds. Fully automated ZF-FreedomLine transmissions are available in 12 and 16 speeds.

Manual Transmissions

Meritor offers constant mesh manual transmissions in 9, 10 and 13 speeds with a full line of torque ratings from 1,150 to 2,050 lb-ft. Transmissions are available with multiple shift system options and with Meritor Torq-2 and Shift-n-Cruise™. Torq-2 provides an extra 100 lb-ft or 200 lb-ft of increased torque in the top-two gears without a significant cost premium. The Shift-n-Cruise™ option is a shift knob with integrated cruise control switches. The pause, set and resume switches are also conveniently located in the knob, eliminating the need for drivers to reach for dashboard controls.

Engine Synchro Shift™ (ESS™) Transmission Shift System

Meritor's Engine Synchro Shift™ (ESS™) transmission shift system monitors the positions of the system switch and shift intent switch, transmission input and output shaft speeds, and the position of the shift lever in the shift tower. The system relays this data to the engine control module (ECM), which sends it to the fuel control system to increase or decrease engine rpm to match road speed. The ECM also controls high and low range selection in the auxiliary case.

SureShift™ Transmission

The SureShift™ option is an electronic shift system that significantly reduces the effort required to safely and accurately shift a constant mesh manual transmission. With the SureShift™ interface, gear shifts are accomplished by simply tapping the joystick on the shift module. The SureShift™ system allows the driver complete control over which gear the vehicle is in at any given time. The clutch pedal is only used for starting and stopping. The SureShift™ system is available with 9- or 10-speed transmissions.

ZF-FreedomLine Transmission

The ZF-FreedomLine is a two-pedal automated transmission that eliminates the clutch pedal for shifting, starting and stopping. The system allows the driver to select automatic mode or manual operation. A self-adjusting clutch is part of the ZF-FreedomLine system. This eliminates the need for clutch or linkage adjustments. The ZF-FreedomLine system is available with 12- or 16-speed transmissions. Figure 12.1.

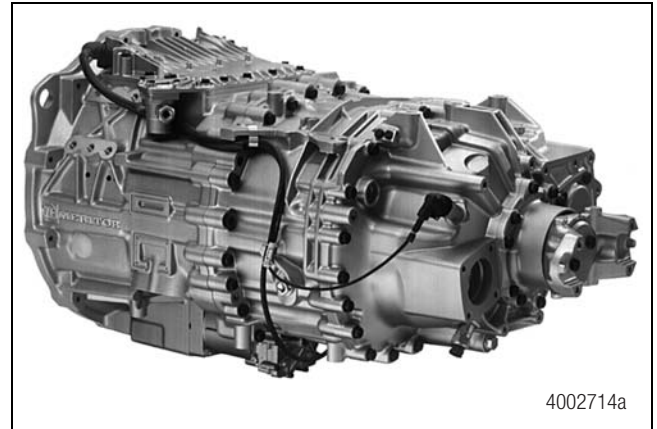

Figure 12.1

Identification

An identification plate is installed on the side of the transmission. Use Figure 12.2, Figure 12.3 and Figure 12.4 to identify the transmission.

12 Transmissions

Model Nomenclature

Refer to Figure 12.2, Figure 12.3 and Figure 12.4 for an explanation of the model identification number and the identification plate.

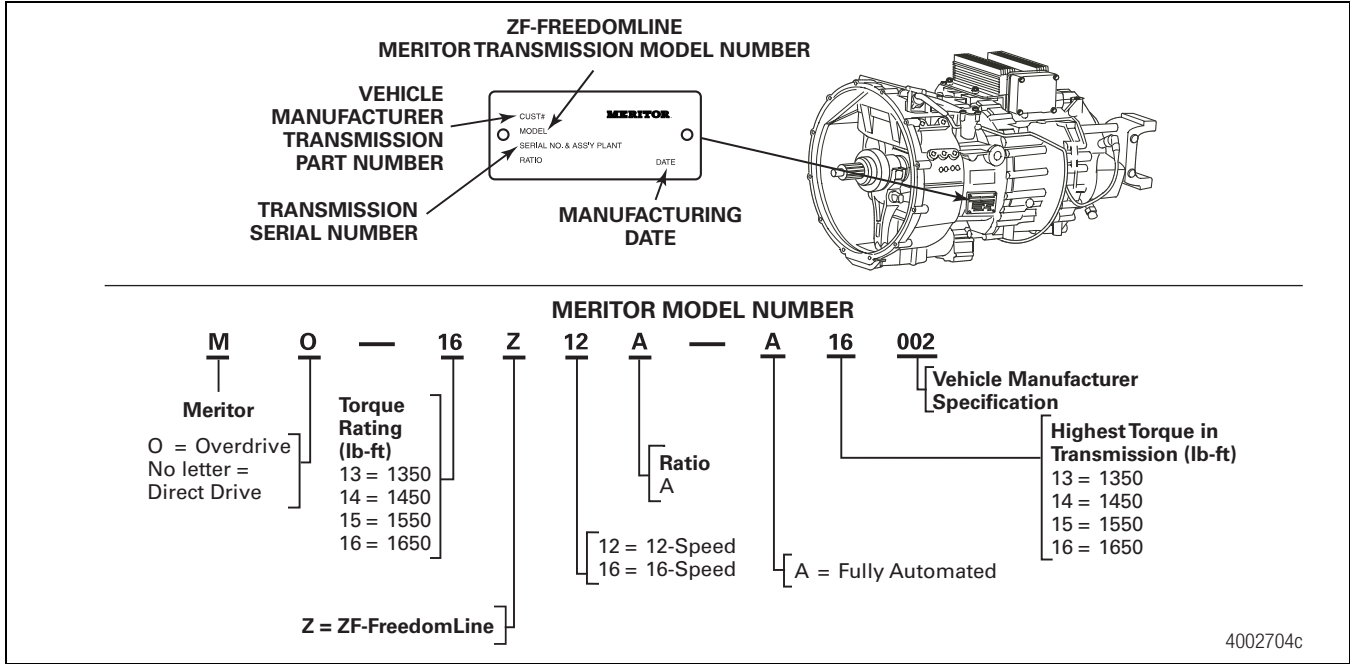

Figure 12.2

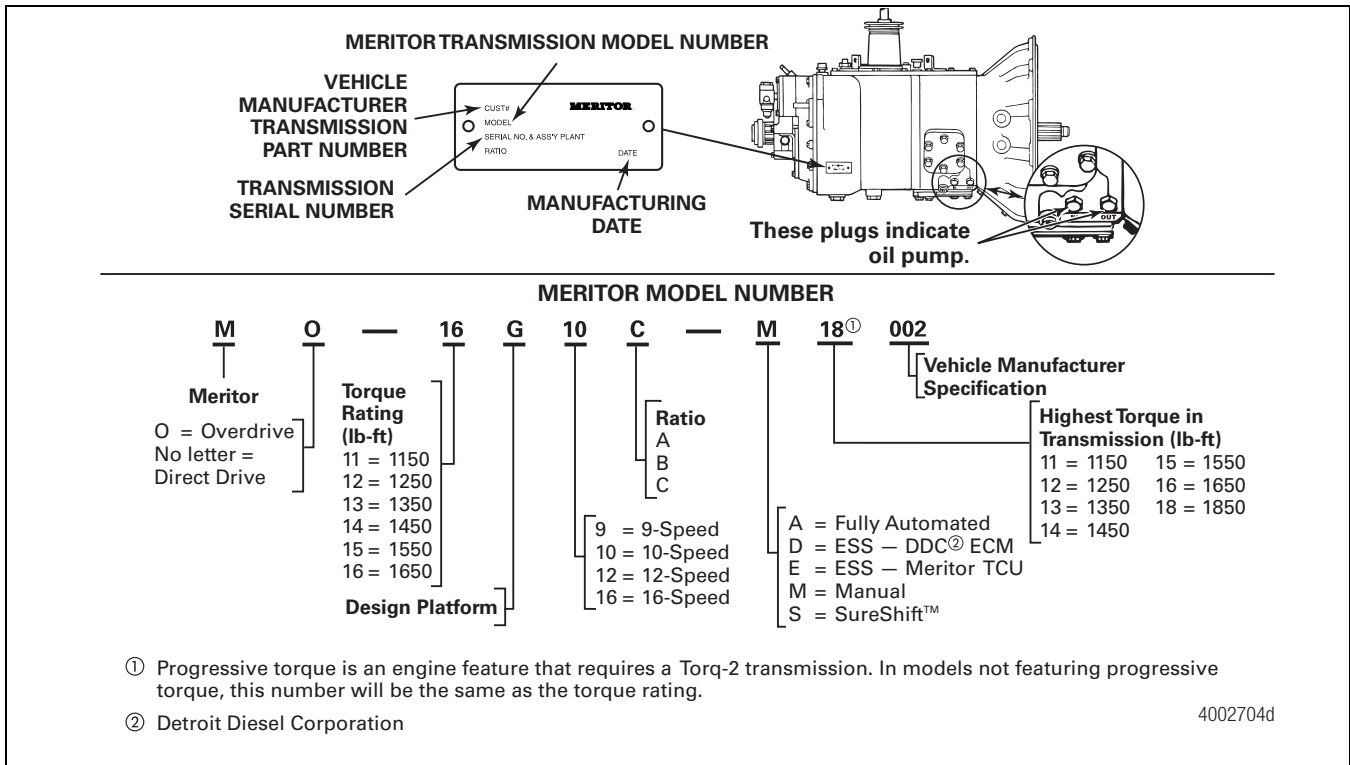

Figure 12.3

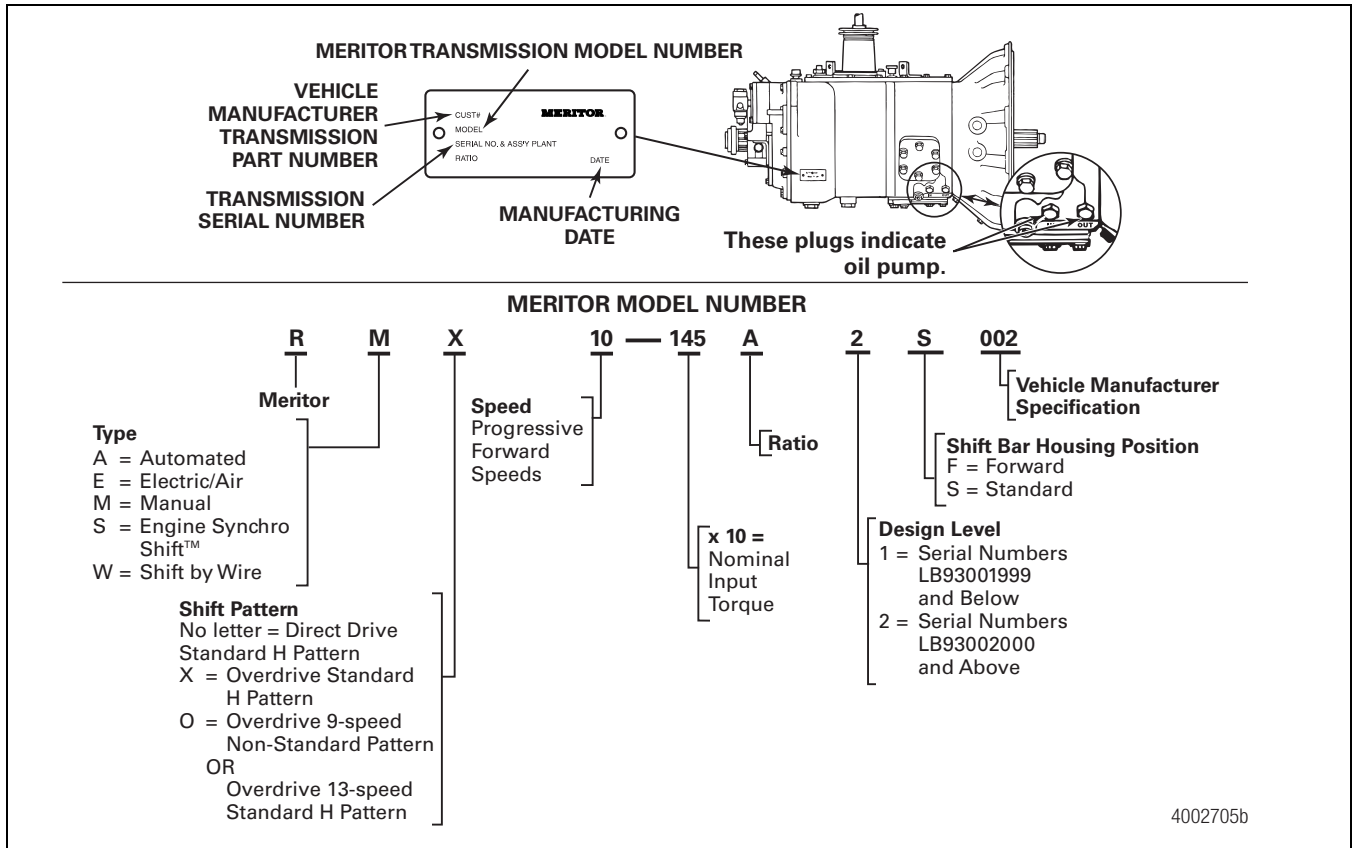

Figure 12.4

Intervals

Every 10,000 Miles (16 000 km) of Vehicle Operation

Table CM: Manual Transmissions, Engine Synchro Shift™ (ESS™), SureShift™ and ZF-FreedomLine

| Check Oil Level | Approved Petroleum Lubricant Oil Change | Approved Synthetic Oil Change |
|--------------------------|---|-------------------------------|
| 10,000 miles (16 000 km) | 50,000 miles (80 000 km) | 500,000 miles (800 000 km)* |

* This interval is for linehaul applications.

- Check and adjust the oil level in the transmission.
- Check the condition of the breather vent.
- Check the torque of the fasteners.
- Inspect for leaks or damage on the transmission. Service as necessary.

Every 50,000 Miles (80 000 km) of Vehicle Operation (Approved Petroleum Base and Heavy-Duty Engine Oils)

- Drain and replace the oil in the transmission with approved petroleum base and heavy-duty engine oils.

Every 500,000 Miles (400 000 km) of Vehicle Operation (Approved Full-Synthetic Oils)

- Drain and replace the oil in the transmission with approved full-synthetic oils.

12 Transmissions

Inspection

Oil Drain Conditions

NOTE: For a list of synthetic oil suppliers, refer to Transmission Technical Bulletins, TP-2053. To obtain this publication, refer to the Service Notes page on the front inside cover of this manual.

Manual Transmission Oils

If used transmission oil analyses indicate that any one of these criteria is not met, drain the used oil and replace it with an oil that is recommended for manual transmissions.

Table CN: Used-Oil Analyses (ppm = parts per million)

| | |
|--------------------------|--|
| Iron (Fe) | If level is greater than 500 ppm, drain and replace the oil. |
| Silicon (Si) | If level is greater than 100 ppm, drain and replace the oil. |
| Water (H ₂ O) | If level is greater than 0.3%, drain and replace the oil. |

Magnets and Magnetic Drain Plugs

All transmissions, except for the ZF-FreedomLine, have magnetic drain plugs and four magnets in the bottom of the main case. The ZF-FreedomLine has magnetic drain plugs only. The magnets and magnetic plugs have a minimum pick-up capacity of 1.5 lbs (0.7 kg) of low carbon steel.

NOTE: Inspect the magnetic drain plug each time the oil is changed. Use the correct part. Pipe plugs will leak if used as a drain plug.

The magnetic drain plug can be reused if, after cleaning, the plug has a minimum pick-up capacity of 1.5 lbs (0.7 kg) of low carbon steel.

Transmission Oil Coolers

Required

Oil coolers are required on:

- All ZF-FreedomLine 12- and 16-speed transmissions
- All 9-, 10- and 13-speed transmissions behind an engine rated at 399 hp or above
- All 9-, 10- and 13-speed transmissions with continuous operating temperatures above 225°F (107°C) or intermittent operating temperatures reaching 275°F (135°C)

Recommended

Oil coolers are recommended on:

- All 9-, 10- and 13-speed transmissions behind an engine rated at 350-398 hp
- Some aerodynamic vehicles which restrict air flow over the transmission causing excessive transmission operating temperatures

Temperature Indicator

The temperature indicator is optional. The temperature sending unit is on the bottom right side of the main case. The normal operating temperature range is less than 225°F (107°C).

Use the temperature indicator gauge to check transmission operation as described in the following example.

- **If the temperature suddenly rises to 275°F (135°C) or more:** Check the transmission for the cause of the increase.
- **When operating a vehicle on a mountain grade, if the temperature increases 50-75°F (10-24°C) but returns to the normal operating temperature:** This indicates a normal operating condition. If the temperature does not return to the normal range, check the transmission.

Check and Adjust the Oil Level

WARNING

Park the vehicle on a level surface. Block the wheels to prevent the vehicle from moving. Support the vehicle with safety stands. Do not work under a vehicle supported only by jacks. Jacks can slip and fall over. Serious personal injury and damage to components can result.

Before Checking the Oil Level

1. The oil must be at room temperature.
2. The vehicle must be parked for at least 10 minutes.

Check and Adjust the Oil Level Every 10,000 Miles (16 000 km)

1. Park the vehicle on a level surface. Place blocks under the wheels to prevent the vehicle from moving.
2. Inspect the transmission for oil leaks. If a transmission oil leak is present, refer to the Troubleshooting section in the appropriate Transmission Maintenance Manual for procedures.

NOTE: If foam appears when you remove the fill plug, the oil is too hot to check. Install the oil plug and allow the oil to cool. If oil flows from the fill plug hole when you remove the plug, the oil level is too high. Drain the oil to the correct level.

3. Clean the area by the fill plug. Remove the fill plug from the side of the transmission.
4. Check the transmission oil level. Verify that it is even with the bottom of the fill plug. If the oil level is below the bottom of the oil fill plug, add the specified oil. Refer to Figure 12.5 for 9-, 10- and 13-speed transmissions. Refer to Figure 12.6 for 12- and 16-speed ZF-FreedomLine transmissions.

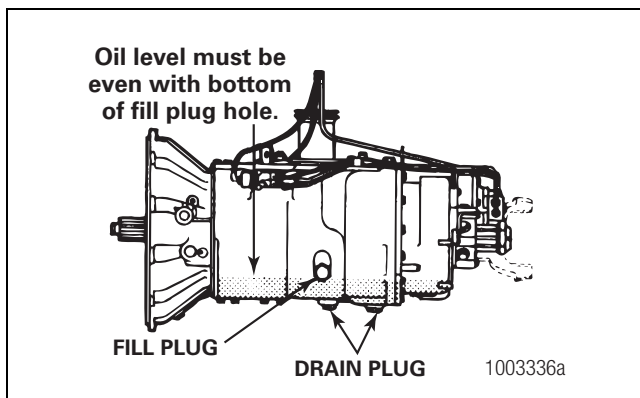

Figure 12.5

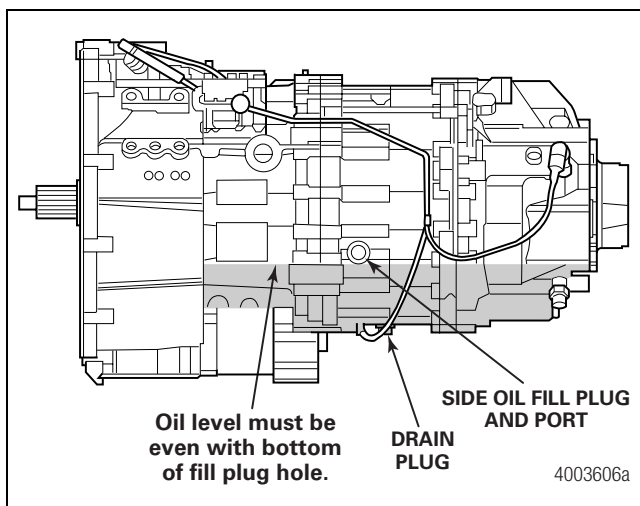

Figure 12.6

5. Install the oil fill plug and tighten to 35-50 lb-ft (48-67 N•m).
6. Operate the vehicle for five minutes. Check for transmission oil leaks and correct operation.
7. Recheck the oil level.

Inspection

Breather Vent Condition

Verify that the breather vent is not damaged. Remove all dirt and oil from the screen in the breather vent. On the ZF-FreedomLine, the breather vent condition can only be checked when the transmission is removed from the vehicle. Figure 12.7.

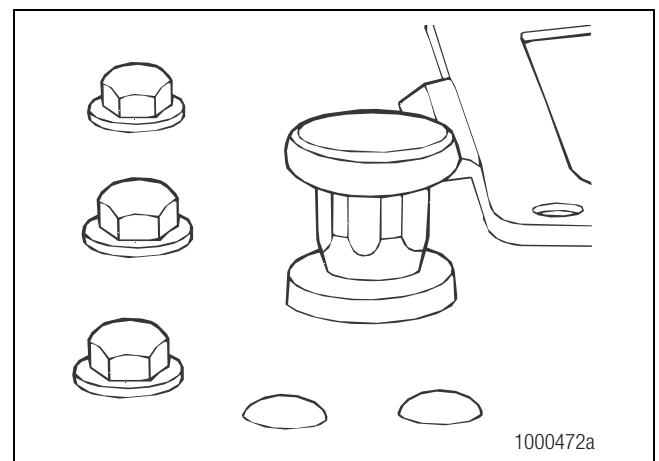

Figure 12.7

Fastener Torque

Check the torque on the following fasteners.

- Clutch housing to engine flywheel
- Top cover housing to main case
- All electrical switches on the top cover housing
- Drain and fill plugs
- PTO covers to main case
- Auxiliary case to main case
- Output bearing retainer to auxiliary case
- Piston housing cover to auxiliary case
- Auxiliary countershaft cover to auxiliary case
- Transmission to frame brackets
- Output yoke to output shaft
- Shift cover housing to top cover housing

12 Transmissions

Inspecting the Transmission for Leaks and Damage

CAUTION

Repair all leaks to prevent damage to the transmission.

Inspect the following transmission parts for cracks, leaks and damage. Verify that the leaks are transmission oil. Repair all leaks.

- Output yoke and the oil seal in the output bearing retainer on the auxiliary case, non-ZF-FreedomLine models
- PTO covers on the main case
- Auxiliary case to main case, non-ZF-FreedomLine models
- Main case and the clutch housing, non-ZF-FreedomLine models
- Clutch housing to flywheel housing
- Auxiliary countershaft covers, non-ZF-FreedomLine models
- Slave valve to the main case, non-ZF-FreedomLine models
- Shift lever and tower assembly to the top cover, non-ZF-FreedomLine models
- Top cover to the main case, non-ZF-FreedomLine models
- Fill and drain plugs
- Output bearing retainer to the auxiliary case
- Input bearing retainer to the main case
- Speedometer bore or electronic speed pick-up in the output bearing retainer
- Middle housing to rear housing on ZF-FreedomLine models

Drain and Replace the Oil

Transmission Oil

NOTE: Drain the oil when the transmission is hot.

1. Park the vehicle on a level surface. Place blocks under the wheels to prevent the vehicle from moving.
2. Place a large container under the transmission. Place a screen on top of the container.
3. Remove the drain plugs from the bottom of the transmission. Drain the oil. Follow U.S. Environmental Protection Agency (EPA) guidelines to recycle used oil.

4. Inspect the screen on top of the container for metal particles and damaged parts.
5. If the transmission is disassembled or replaced and a transmission oil cooler is used, remove the cooler.
 - A. Remove the oil from the oil cooler and the oil lines. Follow EPA guidelines to recycle used oil.
 - B. Install the oil cooler and the oil lines. Tighten the fittings to the vehicle manufacturer's specifications.
6. Install the drain plug and tighten to 35-50 lb-ft (48-67 N•m).
7. Clean the air by the fill plug. Remove the fill plug from the side of the transmission.

CAUTION

Only use the specified oil. Do not use multi-viscosity engine oils or Extreme Pressure (EP) GL-5 gear oils. Damage to components can result. The use of unapproved oils will void Meritor's warranty.

8. Add the specified transmission oil through the fill plug hole. Add the oil until the oil level is even with the bottom of the fill plug hole.
9. Install and tighten the fill plug to 35-50 lb-ft (48-67 N•m). 
10. Operate the vehicle for five minutes. Check for oil leaks and correct operation.
11. Recheck the oil level.

Adjustment

Linkage for the Remote Control Assembly

Cab-Over-Engine (COE) vehicles use a remote control assembly on top of the transmission. The linkage connects the inner shift lever to a shift lever in the cab of the vehicle.

The linkage must be adjusted for correct operation. See the vehicle manufacturer's procedure.

Lubrication

Remote Control Assembly

Apply grease to the fittings on the linkage at the interval specified by the vehicle manufacturer. Use the grease specified by the manufacturer.

ZF-FreedomLine Clutch Fork

Lubricate the parts with Castrol Olista Longtime 3 EP lubricant, Meritor part number 2297-E-8507.

Do not allow grease to enter the inner bushing of the release bearing.

Where to Lubricate

- Do not allow grease to enter the release bearing inner bushing.
- The release fork tips and release bearing, where the fork tips contact the bearing. Figure 12.8.
- The input shaft spline and friction plate area, when installing a new transmission.
- The release fork, where it pivots on the release shaft.
- The ball cup and push rod, where the push rod contacts the ball cup.

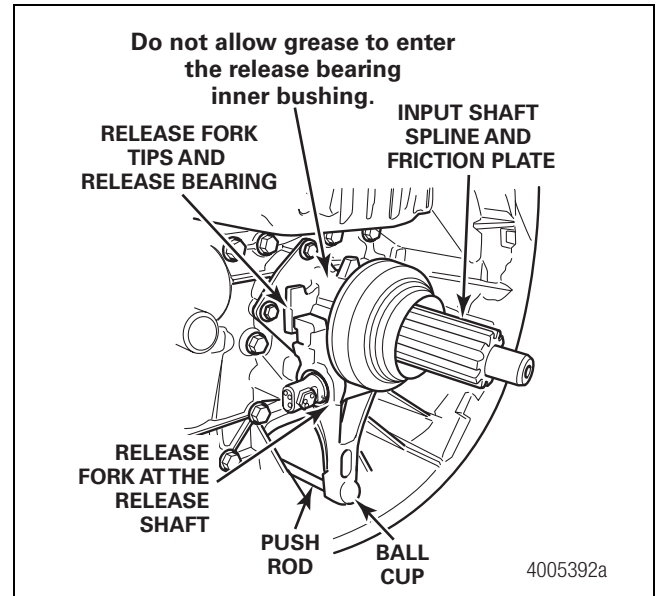

Figure 12.8

Lubrication Intervals and Specifications

Approved Oil

The following oils have been approved for use in all 9-, 10- and 13-speed manual, SureShift™ and ESS transmissions. The oil change interval shown is for linehaul applications. All other applications must use oil analysis to determine oil change intervals.

Table C0: 9-, 10- and 13-Speed Transmissions

| Oil Description ¹ | Meritor Specification | A.P.I. Specification | Military Specification Approval | SAE Grade | Outside Temperature | Change Interval |
|--|-----------------------|--|---------------------------------|-----------|---------------------|-------------------------------|
| Heavy-Duty Engine Oil | — | A.P.I. -CD, -CE, -SG, -SH or SJ ² | MIL-L-2104 E or F ² | 50 | Above 10°F (–12°C) | 50,000 miles (80 000 km) |
| | | | | 40 | Above 10°F (–12°C) | |
| | | | | 30 | Above –15°F (–26°C) | |
| Petroleum GL-1 Oil with Rust and Oxidation Inhibitor | — | A.P.I. - GL-1 | — | 90 | Above 10°F (–12°C) | 50,000 miles (80 000 km) |
| | | | | 80 | Above –15°F (–26°C) | |
| Full-Synthetic Oil | 0-81 | — | — | 50 | Above –40°F (–40°C) | 500,000 miles (800 000 km) |

¹ Do not use multi-viscosity or EP (Extreme Pressure) GL-5 gear oils. DO NOT MIX OILS IN THE TRANSMISSION.

² Current designations are acceptable.

12 Transmissions

The following oils have been approved for use in all 12- and 16-speed ZF-FreedomLine transmissions. The oil change interval shown is for linehaul applications. All other applications must use oil analysis to determine oil change intervals.

Table CP: 12- and 16-Speed ZF-FreedomLine Transmissions

| Description/ Specification | API Spec | Military Spec | Outside Temperature | Change Interval |
|---|----------|---------------|---------------------|-------------------------------|
| Mobiltrans SHC 50 Full-Synthetic Oil | — | — | Above -60°F (-51°C) | 500,000 miles (800 000 km) |
| Cognis Emgard (#2924) 50W Full-Synthetic Oil | — | — | Above -60°F (-51°C) | 500,000 miles (800 000 km) |

Oil Analysis to Determine Oil Change Frequency

The oil in the transmission must also be changed if the oil has been analyzed and contamination has occurred. Refer to Table CN for recommended guidelines.

Table CQ: Transmission Oil Capacities

| Model | Capacity | |
|--|----------|--------|
| | Pints | Liters |
| 9- and 10-speed manual, SureShift™ and ESS™ transmissions | 20.5 | 9.7 |
| 12-speed ZF-FreedomLine transmission | 23.25 | 11.0 |
| 13-speed manual transmission | 22.0 | 10.41 |
| 16-speed ZF-FreedomLine transmission | 25.0 | 11.83 |

Troubleshooting

On Manual Transmissions

When checking a problem with the manual transmission, the first thing to do is to verify the service condition. Talk to the driver, the mechanic or the service manager. If possible, take the vehicle for a road test.

There are three types of problems.

- Leaks
- Noise and/or vibration
- Operating conditions

Oil Leaks

Check the transmission for transmission oil leaks. If you find oil on or under the transmission, verify that the leak is transmission oil and not engine oil, coolant or other lubricants. Note that under normal conditions, the area around the oil seal, yoke and rear bearing retainer is moist. This moist condition is not a transmission leak or an oil seal leak.

On New Transmissions

The following conditions can be found on new transmissions and are not considered oil leaks.

- Lubricants applied to the yoke during assembly can make the seal area appear moist or “leaking.”
- All output seals are pre-lubed with grease that melts at low temperatures. When the grease melts, it comes out of the seals, and the seals only appear to be “leaking.”

Vibration

When checking a noise or a vibration, find out when the problem occurs.

- When the transmission is in NEUTRAL or in gear
- During upshifts or downshifts
- In all gears or specific gears
- In the HI range or the LO range
- In the DIR range or the OD range (13-speed transmission only)
- During coast or acceleration
- With the vehicle loaded or unloaded

Noise

If a noise is the problem, find out the sound of the noise.

- Growling, humming or grinding
- Hissing, thumping or bumping
- Rattles
- Squealing
- Whining

Operation Problems

When the transmission is not operating correctly, find out when the problem occurs.

- In NEUTRAL or in gear
- During upshifts or downshifts
- In the HI range or the LO range
- In the DIR range or the OD range (13-speed transmission only)

Also, find out what the transmission does during the problem

- Does not stay in the selected gear
- Does not stay in the selected range
- Does not select all gears
- Does not select all ranges
- Overheats
- Does not operate

Troubleshooting Leaks

Before troubleshooting a leak condition, verify the following:

1. Clean the outside of the transmission to remove all dirt.
2. Operate the vehicle to verify that the leak is coming from the transmission.
3. Verify that the fluid is transmission oil.
4. The transmission housings are not cracked or broken.

Table CR: Troubleshooting Leaks

| Condition | Cause | Repair |
|--|---|---|
| Leaks — In-Vehicle Repair | Missing fasteners | Replace the missing fasteners. Tighten to the specified torque. |
| | Loose fasteners | Tighten to the specified torque. |
| | High oil level | Drain to the specified level. Refer to Overheating in Operating Conditions. |
| | Unspecified oil in transmission | Drain the oil. Install the specified oil. |
| | Clogged or dirty breather vent | Clean the breather vent. |
| | Damaged yoke | Replace the yoke. ¹ |
| | Damaged output shaft seal | Replace the output shaft seal. ¹ |
| | Worn or damaged sealing tape on electronic speed sensor | Install new sealing tape onto the electronic speed sensor. |
| Leaks — Remove and Disassemble Transmission | Damaged gaskets or sealing material | Replace the gaskets or sealing material. |
| | Cracked or broken housing | Replace the housing. |
| | Oil leaking from breather vent. ² | Replace the O-ring in piston housing. |

¹ If the transmission continues to leak and the output shaft seal and the yoke have been replaced, remove and replace the output shaft assembly.

² Place the transmission in the LO range and operate the vehicle. If air leaks from the breather vent, the O-ring in the housing of the range cylinder is damaged.

12 Transmissions

Troubleshooting Vibrations

Before troubleshooting a leak condition, verify the following:

1. The engine idle speed is within the specified range.
2. The engine is operating correctly.
3. The U-joints, yokes and driveshaft are in good condition. Check the driveline angles. Correct as necessary.
4. The U-joints, yokes and driveshafts are correctly aligned and/or balanced. Correct as necessary.
5. Check the air bag height. Correct as necessary.

Table CS: Troubleshooting Vibrations

| Condition | Cause | Repair |
|--|------------------------------------|--|
| Vibration — In-Vehicle Repair | Fasteners do not remain tight | Tighten the fasteners. If the fasteners do not remain tight, replace the fasteners or housing. |
| Vibration — Remove and Disassemble Transmission | Damaged bearings | Replace the bearings. |
| | Broken or loose synchronizer pins* | Replace the synchronizer. |

* If the transmission does not shift correctly into the selected range, broken or loose synchronizer pins are the result of the vibration condition.

Troubleshooting Noises

For all noise conditions, check the following before disassembling the transmission:

1. Check that the oil level is even with the bottom of the fill plug hole.
2. Verify that the correct oil is used.
3. Verify that the driveline angles of the transmission are correct.
4. Verify that the transmission is correctly installed.
5. Remove the drain plug. Check for any metal shavings, gasket material or any other material in the oil.

In some noise conditions, there are additional repairs to perform. These repairs will be explained in the following charts. See the following charts to troubleshoot the clutch.

Table CT: Troubleshooting Noises

| Condition | Cause | Repair |
|--|---|---|
| Growling, Humming or Grinding ¹ | Worn or damaged gears | Replace the gears. |
| | Worn bearings (humming only) | Replace the bearings. |
| | End play out-of-specifications | Check and adjust the end play. |
| Hissing, Thumping or Bumping ² | Damaged bearings (hissing only) | Replace the bearings. |
| | Damaged gear teeth (thumping or bumping only) | Replace the gears. |
| Rattles — In-Vehicle Repair | Engine idle speed not within specifications | Adjust the idle speed to the specified RPM. |
| | Engine does not operate on all cylinders. | Adjust or repair the engine. |
| | Clutch intermediate or center plate binding in housing ³ | Repair or replace the intermediate or center plate. |
| | Other systems | Verify that the transmission is the source of the rattle condition. |
| | Incorrect shim installation on the PTO unit | Install the correct shims on the PTO unit. |
| Rattles — Remove and Disassemble Transmission | Damaged washers between mainshaft gear | Replace the washers between the mainshaft gears. |
| Squealing or Whining — In-Vehicle Repair ⁴ | Incorrect shim installation on PTO unit | Install the correct shims onto the PTO unit. |
| Squealing or Whining — Remove and Disassemble Transmission ⁴ | Damaged bearings | Replace the bearings. |
| | End play of countershafts not within specifications | Adjust the countershaft end play within specifications. |

¹ Growling and humming are associated with the first stages of the condition. Grinding is associated with the severe stages of the condition.

² Hissing is associated with the first stages of the condition. Thumping and bumping are associated with the severe stages of the condition.

³ If the noise occurs when the clutch is engaged and stops when the clutch is disengaged, the intermediate or center plate is the cause of the rattle.

⁴ Whining is a medium-pitched noise. Squealing is a high-pitched noise.

12 Transmissions

Troubleshooting Operating Conditions

Table CU: Troubleshooting Operating Conditions

| Condition | Cause | Repair |
|---|--|---|
| Transmission Slips Out of the Selected Range — In-Vehicle Repair | Loose air lines and fittings | Tighten the air lines and fittings. |
| | Obstructions in air lines | Change the routing or replace the air lines. |
| | Check operation of filter/regulator assembly. | Replace the filter/regulator assembly if pressure at the delivery port is not within 60-65 psi. |
| | Damaged O-ring on piston in range shift cylinder ¹ | Replace the O-ring on the piston. |
| Transmission Slips Out of the Selected Range — Remove and Disassemble Transmission | Loose or missing nut that fastens piston to shift shaft in range shift cylinder ² | Tighten or replace the nut. |
| | Worn teeth in sliding clutch | Replace the sliding clutch. |
| | Bent or worn shift fork | Replace the shift fork. |
| Transmission is Slow to Shift or Unable to Shift into the Selected Range — In-Vehicle Repair | Worn collar on range shift fork | Replace the collar on the range shift fork. |
| | Loose or leaking air lines and fittings | Tighten or replace the air lines or fittings. |
| | Obstructions in the air lines | Change the routing or replace the air lines. |
| | Filter/regulator assembly does not operate correctly | Replace the filter/regulator assembly if pressure at the delivery port is not 60-65 psi. |
| | Spool binding in slave valve | Replace the slave valve. |
| | Leakage at slave valve ³ | Replace the slave valve. |
| | Damaged piston and/or O-rings in piston housing ⁴ | Replace the O-rings and/or piston in the piston housing. |
| | Worn or damaged neutral interlock pin | Replace the pin. |
| | Damaged shift knob/selector valve | Replace the shaft knob/selector valve. |
| | Damaged exhaust disc in slave valve | Replace the disc in the slave valve. |
| Transmission is Slow to Shift or Unable to Shift into the Selected Range — Remove and Disassemble Transmission | Damaged output shaft | Replace the output shaft. |
| | Broken or missing synchronizer springs or pins | Replace the synchronizer springs or synchronizer. |
| | Damaged synchronizer | Replace the synchronizer. |
| | Bent or broken shift shaft in range cylinder | Replace the shift shaft. |
| | Bent or broken shift fork in range cylinder | Replace the shift fork. |
| | Dirt between splines and gear | Drain the oil. Flush the inside of the housing. Fill to the specified level with new fluid. |
| | Missing HI/LO fork pin and nut | Replace the HI/LO fork pin and nut. |
| | Incorrect clutch use | Verify that the driver uses the clutch correctly. |
| | Linkage binding or does not move freely | Lubricate, repair or replace the linkage. |
| | Clutch out-of-adjustment | Adjust the clutch. Verify that the clutch engages and releases correctly. |
| Transmission Slips Out of the Selected Gear — In-Vehicle Repair | Remove shift linkage out-of-adjustment | Adjust the remote shaft linkage. |
| | Loose or damaged engine and/or cab mounts | Tighten the fasteners of loose mounts to the specified torque. Replace the damaged mounts. |
| | Incorrect driveline angles | Adjust the driveline angles. |
| | Weak or broken detent spring in top cover assembly | Replace the detent spring in the top cover assembly. |

Table CU: Troubleshooting Operating Conditions

| Condition | Cause | Repair |
|--|--|--|
| Transmission Slips Out of the Selected Gear — Remove and Disassemble Transmission | Worn pads on shift fork | Replace the shift fork. |
| | Worn teeth in sliding clutch | Replace the sliding clutch. |
| | Worn fork slot on sliding clutch | Replace the sliding clutch. |
| | Broken key on mainshaft | Replace the key and/or mainshaft. |
| | Twisted mainshaft | Replace the mainshaft. |
| Transmission Is Hard to Shift or Unable to Shift Into the Selected Gear — In-Vehicle Repair | Incorrect vehicle operation | Verify that the driver operates the vehicle correctly. |
| | Clutch out-of-adjustment | Adjust the clutch. Verify that the clutch engages and releases correctly. |
| | Remote shift linkage binding or unable to move | Lubricate, repair or replace the remote shift linkage. |
| | Loose and/or damaged cab and/or engine mounts | Tighten the fasteners of loose mounts to the specified torque. Replace the damaged mounts. |
| | Detent spring too strong or broken | Replace the detent spring. |
| Transmission Is Hard to Shift or Unable to Shift Into the Selected Gear — Remove and Disassemble Transmission | Bent shift shaft in top cover assembly | Replace the shift shaft. |
| | Burr on shift shaft in top cover assembly | Replace the shift shaft. |
| | Cracked top cover assembly | Replace the top cover assembly. |
| | Twisted mainshaft | Replace the mainshaft. |
| | Broken key on mainshaft | Replace the key and/or mainshaft. |
| Transmission Grinds or Initial Engagement — In-Vehicle Repair | Broken or bent shift fork on sliding clutch | Replace the fork. |
| | Driver does not operate vehicle correctly. | Verify that the driver operates the vehicle correctly. |
| | Clutch out-of-adjustment | Adjust the clutch. Verify that the clutch engages and releases correctly. |
| | Worn, damaged or missing clutch brake | Replace the clutch brake. Verify that the clutch engages and releases correctly. |
| | Clutch and/or remote shift housing linkage binding or unable to move | Lubricate, repair or replace the linkage. |
| Shift Lever Locks or Sticks in Gear — In-Vehicle Repair | Worn bushings in side of clutch housing | Replace the bushings in the clutch housing. |
| | Remote shift linkage out-of-adjustment | Adjust the remote shift linkage. |
| | Clutch linkage needs adjustment | Adjust the clutch linkage. |
| | Linkage binding or unable to move | Lubricate, repair or replace the linkage. |
| | Loose or damaged cab and/or engine mounts | Tighten the fasteners of loose mounts to the specified torque. Replace the damaged mounts. |
| Shift Lever Locks or Sticks In Gear — Remove and Disassemble Transmission | Damaged balls or rails in top cover assembly | Replace the balls or rails. |
| | Bent shift fork in top cover | Replace the shift fork. |
| | Damaged shift shaft in top cover | Replace the shift shaft. |
| | Damaged mainshaft | Replace the mainshaft. |

12 Transmissions

Table CU: Troubleshooting Operating Conditions

| Condition | Cause | Repair |
|--|--|--|
| Transmission Overheats — In Vehicle ^{5, 6} | Incorrect oil level | Fill to the specified level. |
| | Incorrect oil | Drain the oil. Use the specified oil. |
| | Damaged temperature gauge ⁷ | Replace the temperature gauge. |
| Transmission Does Not Operate — Remove and Disassemble Transmission | Missing or damaged interlock ball in top cover | Replace the interlock ball in the top cover. |
| | Free running gears are locked | Replace the gears. |
| | Mismatched gear sets | Install the correct gear sets. |
| | Timing marks on gears not aligned | Align the timing marks on the gears. |
| | Broken shafts | Replace the shafts. |

¹ To check leakage at the range cylinder, first place the selector valve in the **LO** range. Disconnect the air line to the **HI** range port on the piston housing. Operate the vehicle to charge the air system. If air leaks are heard, the O-ring or the piston must be replaced.

² When the nut is loose or missing at the end of the shift shaft, the transmission will shift into the **HI** range but not into the **LO** range.

³ To check leakage at the slave valve, first place the selector valve in the **LO** range. Disconnect the air lines on the slave valve that goes to the **HI** range port of the piston housing. Operate the vehicle to charge the air system. If air is heard leaking inside the slave valve, the valve is the cause of the leak.

⁴ To check for leaks at the piston housing, disconnect the air lines at the piston housing. Apply air pressure to each port, one port at a time. If air leaks past the piston, the O-ring and/or the piston must be replaced. If the piston does not move, the shift shaft or the shift assembly is damaged.

⁵ If a noise is present along with the overheating condition, refer to the "Troubleshooting Noise" chart to identify and service the noise.

⁶ If the oil is at the specified level and the specified oil is used, but the transmission overheats and the oil smells burnt, the transmission must be disassembled and inspected.

⁷ If the oil does not have a burnt smell and the temperature gauge indicates overheating, remove and replace the gauge.

Hazard Alert Messages

Read and observe all Warning and Caution hazard alert messages in this publication. They provide information that can help prevent serious personal injury, damage to components, or both.

⚠ WARNING

To prevent serious eye injury, always wear safe eye protection when you perform vehicle maintenance or service.

Park the vehicle on a level surface. Block the wheels to prevent the vehicle from moving. Support the vehicle with safety stands. Do not work under a vehicle only supported by jacks. Jacks can slip or fall over. Serious personal injury and damage to components can result.

Technical Publications

How to Obtain Additional Maintenance and Service Information

Refer to the publications in Table CV. To obtain these publications, refer to the Service Notes page on the front inside cover of this manual.

Table CV: Publications

| Model | Manual |
|---|----------------------------|
| Front Non-Drive Steer Axles | Maintenance Manual 2 |
| MX Series Medium-Duty Front Drive Steer Axles | Maintenance Manual MM-0170 |
| Heavy-Duty Front Drive Steer Axles | Maintenance Manual 12 |
| Trailer Axles | Maintenance Manual 14 |

Conventional Wheel Ends

Description

Conventional wheel ends have the hub, seal, lubricant and bearings installed onto the axle spindle as separate components.

Figure 13.1. The bearings and seals require periodic inspections and lubrication to maintain performance.

Trailer axles with conventional wheel ends can be identified by the following features.

- The TN/TQ Series axles use the most common wheel bearings in the trailer industry.
- The TR Series axles use wheel bearings compatible with drive axles.
- The TP Series axles use bearings compatible with Freuhauf axles.

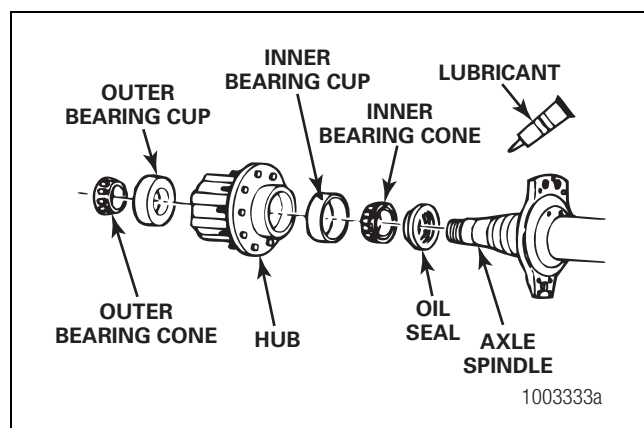
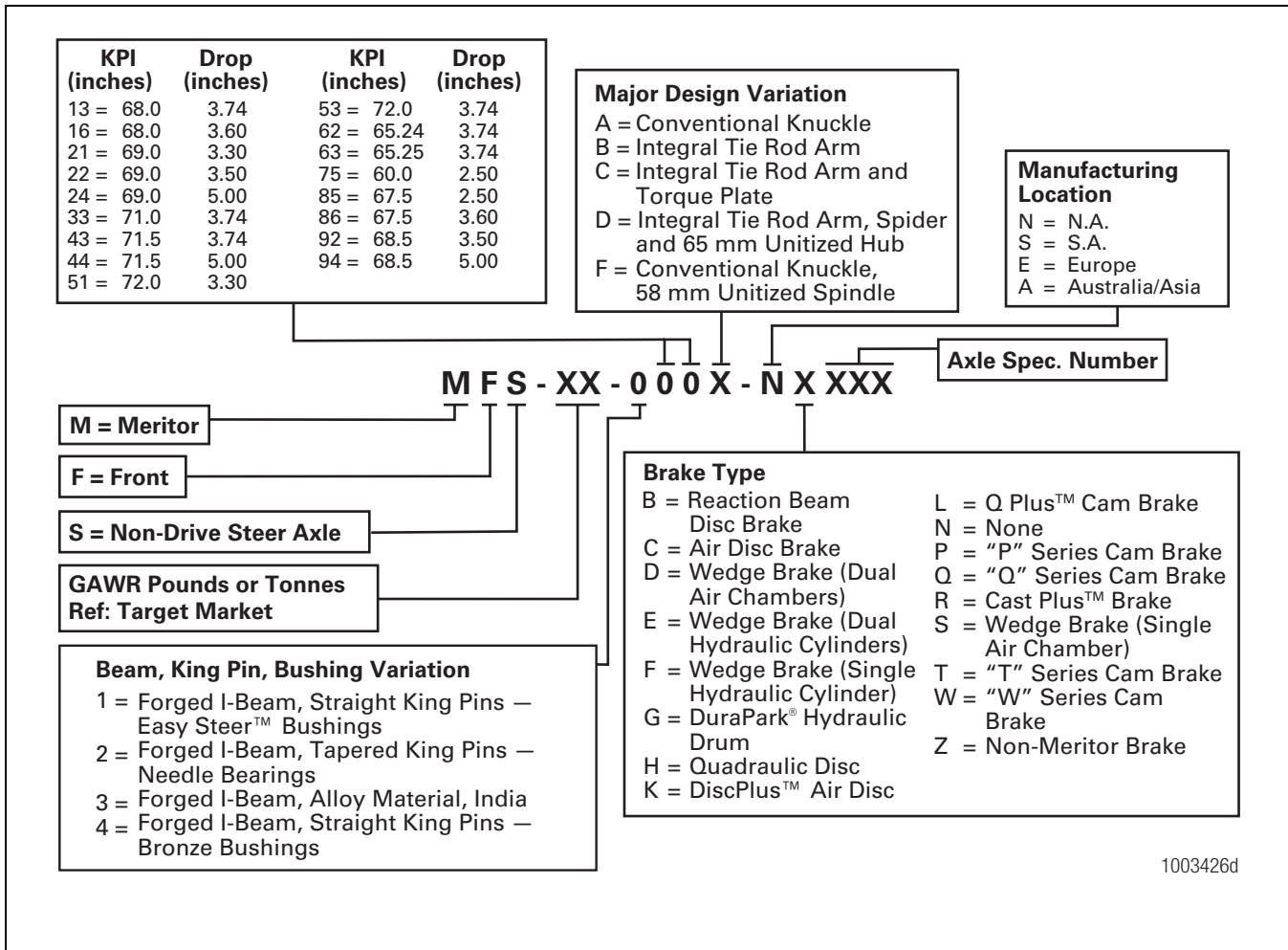

Figure 13.1

13 Wheel Bearings and Wheel Ends

Model Nomenclature

Refer to Figure 13.2 and Figure 13.3 for an explanation of axle model numbers.



1003426d

Figure 13.2

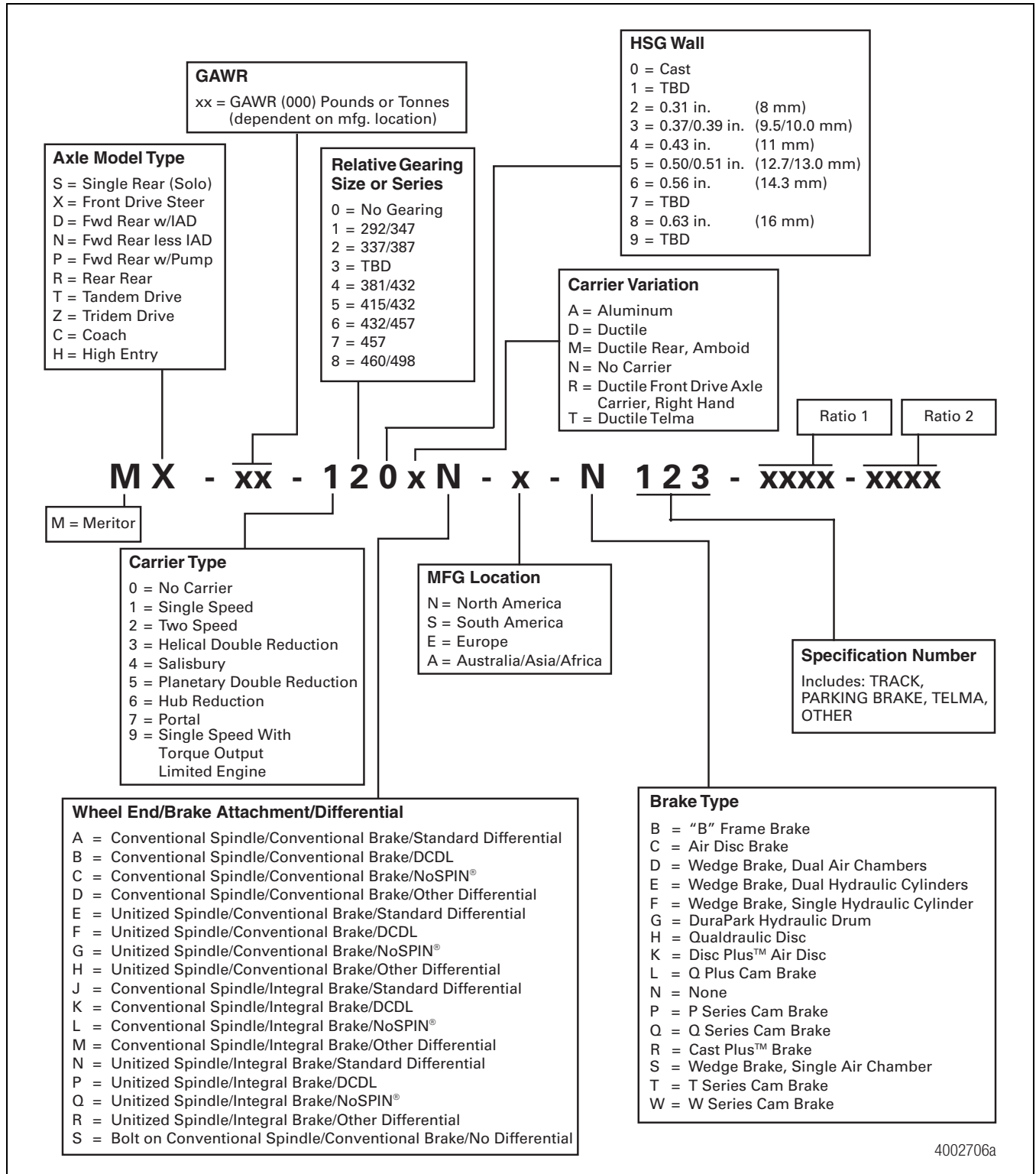

Figure 13.3

13 Wheel Bearings and Wheel Ends

Oil-Lubricated Wheel Bearings

Inspection and Maintenance

If you cannot observe the oil level because the sightglass is stained, remove the fill plug, check the oil level with your finger and follow the procedures for Step 3 below. Replace the stained sightglass as soon as possible.

1. Park the vehicle on a level surface. Place blocks under the wheels to prevent the vehicle from moving.
2. Check the oil level on the cap.
3. If the oil level is more than 1/4-inch (6 mm) below the specified level on the cap, remove the fill plug.
4. Add the specified oil to the specified level. Figure 13.4.

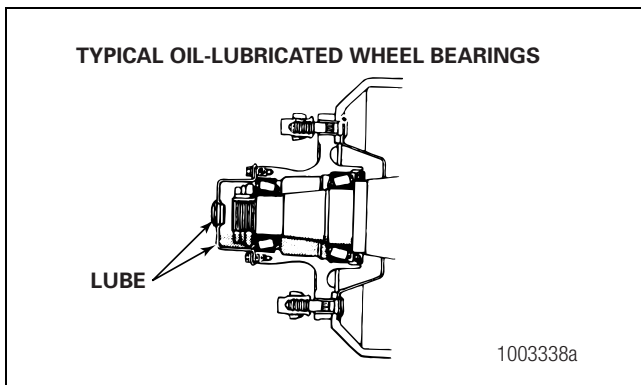

Figure 13.4

5. Install the fill plug.

Drive Axle Hubs Without Fill Holes

1. Add the specified amount of lubricant through the carrier or housing bowl oil fill hole.
2. Tilt the axle to the right and to the left to let the oil flow into the hub cavities. Keep the axle tilted for one minute in each position.
3. With the axle in the level position, add the specified oil so that the level is even with the bottom of the fill plug hole.
4. Install and tighten the fill plug.

Trailer Axle Wheel-End Oil Change

⚠ CAUTION

It is important to not overfill the wheel-end cavity with lubricant. The wheel-end oil level should never exceed the middle of the hubcap. Also, verify that any excess oil is wiped away since it can contaminate the brake linings and cause poor performance. Damage to components can result.

Inspect the wheel-end oil level at least every 1,000 miles (1600 km). To check, verify that the vehicle is on level ground. Clean the hubcap window and observe the oil level. Add lubricant if the oil level is down more than 0.25-inch (6.3 mm) from the fill line.

Figure 13.5.

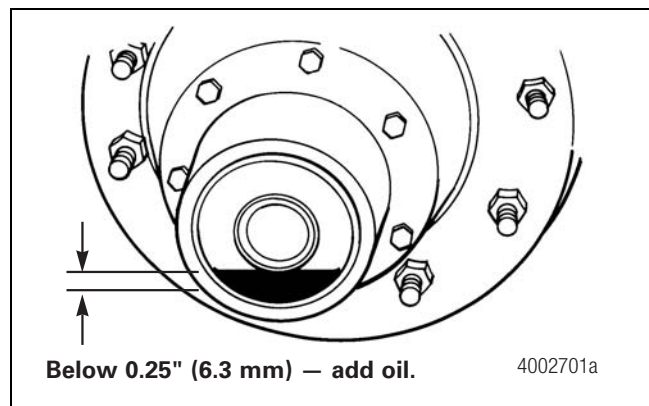

Figure 13.5

Fill the wheel end with an approved gear oil to the hubcap fill line. Note that the oil must be given sufficient time to settle prior to the final check of the oil level. This is especially important in cold conditions. Figure 13.6.

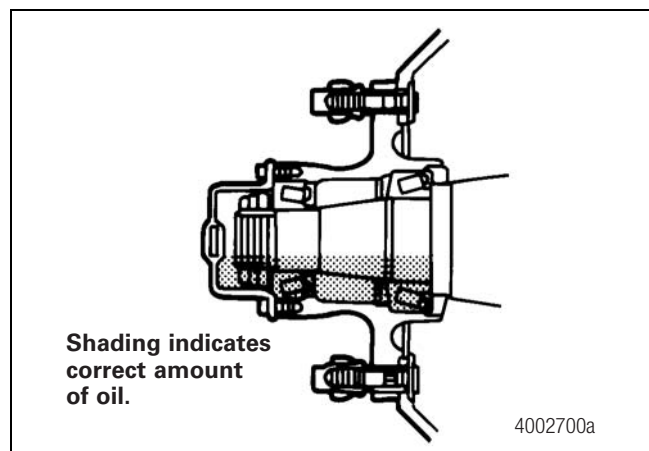

Figure 13.6

Lubrication Intervals and Specifications

Table CW: Wheel-End Oil Change Intervals

| Operation | On-Highway | Off-Highway |
|-----------------------------|---|---|
| Check Oil Level | 1,000 miles (1600 km) | 1,000 miles (1600 km) |
| Petroleum Oil Change | Whichever comes first. Seals replaced. Brakes relined. 100,000 miles (160 000 km). Once a year. | Whichever comes first. Seals replaced. Brakes relined. Once a year. |
| Synthetic Oil Change | Whichever comes first. Seals replaced. Brakes relined. 100,000 miles (160 000 km). Once a year. | Whichever comes first. Seals replaced. Brakes relined. Once a year. |

Table CX: Approved Lubricants

| Meritor Specifications | Military/SAE Specifications | Oil Description | Outside Temperature | | | |
|---------------------------|------------------------------|--|---------------------|------|------|------|
| | | | °F | | °C | |
| | | | Min. | Max. | Min. | Max. |
| O-76-A Gear Oil | MIL-PRF-2105-E and SAE J2360 | GL-5, SAE 85W/140 | -10 | None | -12 | None |
| O-76-D Gear Oil | | GL-5, SAE 80W/90 | -15 | None | -26 | None |
| O-76-E Gear Oil | | GL-5, SAE 75W/90 | -40 | None | -40 | None |
| O-76-J Gear Oil | | GL-5, SAE 75 | -40 | 35 | -40 | 2 |
| O-76-M Full-Synthetic Oil | | GL-5, SAE 75W/140 | -40 | None | -40 | None |
| O-76-N Full-Synthetic Oil | | GL-5, SAE 75W/90 | -40 | None | -40 | None |
| Heavy-Duty Engine Oil | MIL-L-2104 E or F | A.P.I. -CD, -CE, -SG, -SH or -SJ SAE 40 or 50 ¹ | -10 | None | -12 | None |
| Heavy-Duty Engine Oil | MIL-L-210 E or F | A.P.I. -CD, -CE, -SG, -SH or -SJ SAE 30 ^{1,2} | -15 | None | -26 | None |

¹ Current designations are acceptable. Multi-grade engine oils are acceptable if the SAE rating ends in 40 or 50.

² Current designations are acceptable. Multi-grade engine oils are acceptable if the SAE rating ends in 30.

13 Wheel Bearings and Wheel Ends

Table CY: TP and TN Series Trailer Axles Equipped with Conventional Hub Assemblies or PreSet[®] by Meritor¹ Hub Assemblies

| Trailer Axle Series, Hub Assembly Type, and Hub Part Number ² | Lubricant Volume per Wheel End | | |
|---|--|--|---------------------------------|
| | API-GL5 Oil | NLGI 00 Semi-Fluid Grease ³ | NLGI 1 or 2 Grease ³ |
| TP Series PreSet [®] hub assembly Hub part number 16040 | Hubcap Fill Line Approx. 24.55 fl. oz. (44.31 cu. in.) | 35.00 fl. oz. (63.16 cu. in.) | NOT RECOMMENDED |
| TP Series Conventional hub assembly Hub part number 15968 | Hubcap Fill Line Approx. 24.55 fl. oz. (44.31 cu. in.) | 33.47 fl. oz. (60.41 cu. in.) | 23.37 fl. oz. (42.17 cu. in.) |
| TN Series PreSet [®] hub assembly Hub part number 16048 | Hubcap Fill Line Approx. 15.17 fl. oz. (27.37 cu. in.) | 31.00 fl. oz. (55.95 cu. in.) | NOT RECOMMENDED |
| TN Series Conventional hub assembly Hub part number 15984 | Hubcap Fill Line Approx. 15.17 fl. oz. (27.37 cu. in.) | 25.57 fl. oz. (46.15 cu. in.) | 21.22 fl. oz. (38.29 cu. in.) |

¹ The PreSet[®] by Meritor hub assembly is equipped with pre-installed bearings, cups and cones, and oil seals and studs. A precision tubular spacer between the bearings eliminates manual bearing adjustments. The hub subassembly also includes an integral tooth wheel for vehicles equipped with an anti-lock braking system (ABS).

² The hub part number is cast into the inboard side of the wheel mounting flange.

³ Volume includes the lubricant volume of the bearing cones. PreSet[®] bearings are not greased prior to installation.

Table CZ: Conventional Trailer Axle Wheel-End Oil Change Intervals and Specifications

| Check Oil Level | Oil Change* | Meritor Specification | Specification Approval | Oil Description | Outside Temperature | | | |
|-----------------------|--|--------------------------------|-------------------------------|------------------|---------------------|---------|---------|---------|
| | | | | | °F Min. | °F Max. | °C Min. | °C Max. |
| 1,000 miles (1600 km) | <p>General Service: Change oil if the wheel end is disturbed during wheel or hub removal or if the oil is contaminated.</p> <p>Standard-Duty Service: For 100,000 miles (160 000 km) or more a year, change the oil every 100,000 miles (160 000 km). For less than 100,000 miles (160 000 km) a year, change the oil once a year.</p> <p>Heavy-Duty Service: For 60,000 miles (96 000 km) or more a year, change oil every 30,000 miles (48 000 km). For less than 60,000 miles (96 000 km) a year, change the oil every 6 months.</p> | 0-76-A Gear Oil | MIL-PRF-210 5-E and SAE J2360 | GL-5 SAE 85W/140 | -10 | None | -12 | None |
| | | 0-76-D Gear Oil | | GL-5 SAE 80W/90 | -15 | None | -26 | None |
| | | 0-76-E Gear Oil | | GL-5 SAE 75W/90 | -40 | None | -40 | None |
| | | 0-76-J Gear Oil | | GL-5 SAE 75W | -40 | 35 | -40 | 2 |
| | | 0-76-L Gear Oil | | GL-5 SAE 75W/140 | -40 | None | -40 | None |
| | | 0-76-M Full-Synthetic Gear Oil | | GL-5 SAE 75W/140 | -40 | None | -40 | None |
| | | 0-76-N Full-Synthetic Gear Oil | | GL-5 SAE 75W/90 | -40 | None | -40 | None |
| | | 0-81 Full-Synthetic Oil | | SAE 50 | -40 | None | -40 | None |

* The recommended oil change interval is based on operating conditions, speeds and loads. Limited service applications may allow the recommended interval to be increased. Severe service applications may require the recommended interval to be reduced. For more information, contact ArvinMeritor's Customer Service Center at 800-535-5560.

Grease-Lubricated Wheel Bearings

Inspection and Maintenance

1. Park the vehicle on a level surface. Place blocks under the wheels to prevent the vehicle from moving.
2. Raise the vehicle so that the wheels are off the ground. Support the vehicle with safety stands.
3. Remove the tire and wheel assembly. Remove and disassemble the hub.
4. Use the correct cleaning solvent to remove the old grease from all parts. Discard the seals. Inspect the wheel bearings for wear or damage. Replace worn or damaged bearings.
5. Before installing the wheel bearings, lubricate the bearing journals on the spindle with the grease that is used for the bearings.
6. Use a pressure packer to force the specified grease from the large end of the cones into the cavities between the rollers and cage. Pack the hub between the bearing cups with grease to the level of the smallest diameter of the cups.
 - **If a pressure packer is not available:** Grease the bearings by hand.
7. Install the inner and outer bearing cones into the cups in the hubs. The bearing cups must be pressed tight against the shoulder in the hubs.
8. Install new wheel seals into the hubs.
9. Install the hub and the wheel and tire assembly. Install the outer wheel bearing cone into the hub. Install the adjusting nut.
10. Adjust the wheel bearings.

13 Wheel Bearings and Wheel Ends

Trailer Axle Wheel-End Grease Change

⚠ WARNING

Do not use gasoline to clean parts. Gasoline can explode or burn and cause serious personal injury.

⚠ CAUTION

It is important to not overfill the wheel-end cavity with lubricant. Do not extend the grease level indicated below. Also, verify that the excess grease is wiped away since it can contaminate the brake linings and cause poor brake performance. Damage to components can result.

NOTE: Instructions for installing components such as seals, bearings and hubs are located in Maintenance Manual 14, Trailer Axles. To obtain this publication, refer to the Service Notes page on the front inside cover of this manual.

1. To remove grease from a wheel end, use a stiff fiber brush, not steel, and kerosene or diesel fuel oil, not gasoline. Allow the clean parts to dry, then wipe with a clean, absorbent cloth. Note that any solvent residue must be completely wiped dry since it may either dilute the grease or prevent it from correctly adhering to the wheel-end components.
2. Lubricate a wheel end with approved NLGI 1 or 2 grease as follows.
 - A. Pack the bearing cones with grease by forcing the grease into the cavities between the rollers and the cage from the large end of the cone. The use of a pressure packer is recommended; otherwise, pack the bearings by hand.
 - B. Apply a light coat of grease to the spindle bearing journals.
 - C. Pack the area of the hub between the two bearings with grease up to the smallest diameter of the bearing cups. Figure 13.7.
 - D. Apply a light coat of grease to the interior of the hubcap and wheel retention hardware to indicate what lubricant is installed as well as help prevent corrosion of these parts.

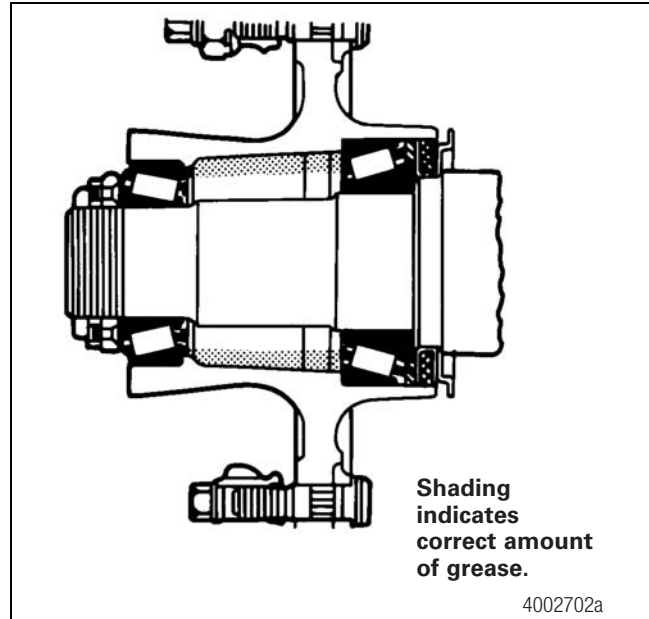

Figure 13.7

3. Lubricate a wheel end with approved NLGI 00 grease as follows.
 - A. Pack the bearing cones with grease by forcing the grease into the cavities between the rollers and the cage from the large end of the cone. The use of a pressure packer is recommended; otherwise, pack the bearing by hand.
 - B. Apply a light coat of synthetic grease to the spindle bearing journals. Refer to A in Figure 13.8.
 - C. Install the hub onto the spindle without the outer bearing cone in place.
 - D. Fill the hub cavity with synthetic grease to the outer cup's smallest diameter. Refer to B in Figure 13.8.
 - E. At the top of the spindle and as far back as possible, pump additional synthetic grease until it appears that the grease will run out. Install the outer bearing cone quickly. Refer to C in Figure 13.8.
 - F. The hub cavity will be filled approximately 1/3 full with grease, from the four to the eight o'clock positions. Figure 13.8.

NOTE: Do not install any grease in the hubcap.

- G. Install the wheel retention hardware. Place a dab of synthetic grease across the face of the outer locknut for identification.

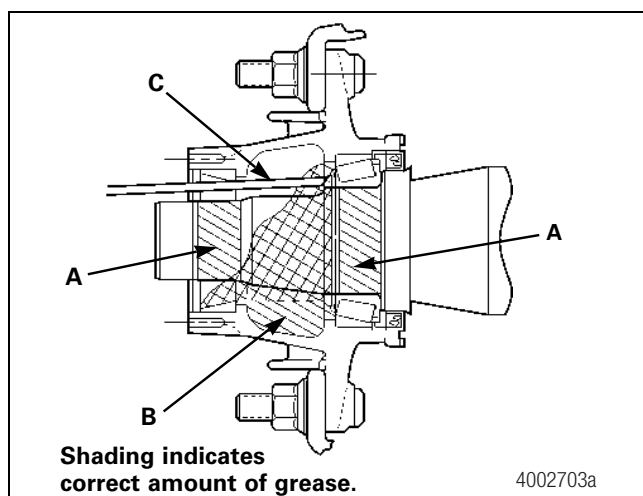

Figure 13.8

Lubrication Intervals and Specifications

Table DA: Wheel-End Axle Greasing Intervals and Specifications

| Greasing Interval | Grease | Meritor Specification | NLGI Grade | Grease Description | Outside Temperature |
|---|----------------------|--|------------|---|--|
| Whichever comes first: Replacing Seals Relining Brakes On-Highway: 30,000 miles (48 000 km)/Once a year On/Off Highway and Off-Highway: 15,000 miles (24 140 km)/Twice a year | Multi-Purpose Grease | 0-617-A (preferred) or 0-617-B (acceptable) | 1 or 2 | Lithium 12-Hydroxy Stearate or Lithium Complex | Refer to the grease manufacturer's specifications for the temperature service limits. |

Table DB: Conventional Trailer Axle Greasing Intervals and Specifications

| Greasing Interval* | Grease | Meritor Specification | NLGI Grade | Grease Description | Outside Temperature |
|--|----------------------|-----------------------|------------|---|--|
| General Service: Grease the bearings if the wheel end is disturbed during wheel or hub removal or if the grease is contaminated. | Multi-Purpose Grease | 0-617-A or 0-617-B | 1 or 2 | Lithium 12-Hydroxy Stearate or Lithium Complex | Refer to the grease manufacturer's specifications for the temperature service limits. |
| Standard-Duty Service: For 100,000 miles (160 000 km) or more a year, grease the bearings every 100,000 miles (160 000 km). For less than 100,000 miles (160 000 km) a year, grease the bearings once a year. | Trailer Axle Bearing | 0-647 | 00 | Lithium Complex | Refer to the grease manufacturer's specifications for the temperature service limits. |
| Heavy-Duty Service: For 60,000 miles (96 000 km) or more a year, grease the bearings every 30,000 miles (48 000 km). For less than 60,000 miles (96 000 km) a year, grease the bearings every 6 months. | | | | | |

* The recommended greasing interval is based on operating conditions, speeds and loads. Limited service applications may allow the recommended interval to be increased. Severe service applications may require the recommended interval to be reduced. For more information, contact ArvinMeritor's Customer Service Center at 800-535-5560.

13 Wheel Bearings and Wheel Ends

Important Information

Meritor automatic slack adjusters (ASAs) should not need to be manually adjusted in service. ASAs should not have to be adjusted to correct excessive pushrod stroke. The excessive stroke may be an indication that a problem exists with the foundation brake, ASA, brake actuator or other system components.

Meritor recommends troubleshooting the problem, replacing suspect components and then confirming proper brake operation prior to returning the vehicle into service.

In the event that a manual adjustment must be made (although not a common practice), a service appointment and full foundation brake, ASA, and other system component inspection should be conducted as soon as possible to ensure integrity of the overall brake system.

For Meritor brake adjustment, refer to the brake adjustment tables in this manual. For non-Meritor brake adjusters, refer to the brake manufacturer's service procedures.

Long-Life Wheel Ends

Front Non-Drive Steer Axles with Unitized Hubs

A unitized hub is a sealed assembly with a bearing package that's greased for the life of the component. Wheel bearing adjustment, seal installation and periodic lubrication are not required.

If you disassemble or attempt to repair or lubricate a unitized hub, you will void Meritor's warranty.

A unitized hub is not adjustable. You don't set or adjust wheel bearing end play.

You must inspect a hub assembly for the life of the component. The inspection procedures in this section do not instruct you to disassemble a unitized hub.

Meritor front non-drive steer axles with unitized hubs use conventional brakes, automatic slack adjusters, and tire and wheel assemblies. For service information on Meritor cam brakes and automatic slack adjusters, refer to the Service Notes page on the front inside cover of this publication.

Axle spindle retention hardware consists of an inner tabbed lock washer and inner wheel bearing adjusting nut, and an outer tabbed lock washer and outer wheel bearing adjusting nut.

Identification

A Meritor front non-drive steer axle with unitized hubs has "half moons" embossed on the center of the hubcaps. Figure 13.9. If the hubcaps are missing, you can use the axle model number to determine if the axle is equipped with unitized hubs. To identify the model number, check the identification tag located on the front of the axle beam.

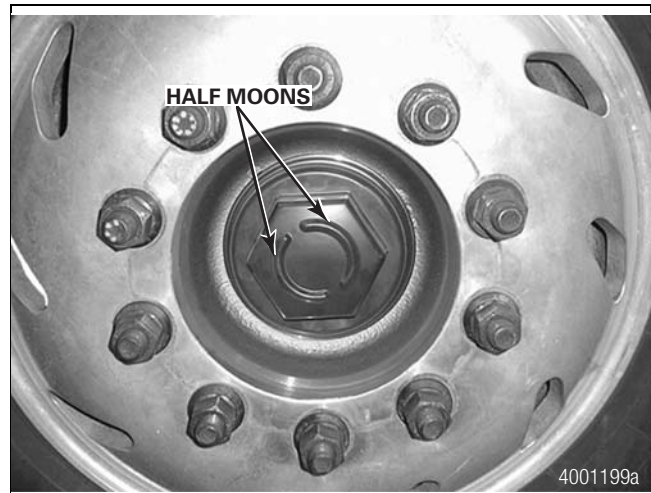

Figure 13.9

The axle identification tag fastened to the center of the axle beam shows the model and specification number, and axle assembly date for Meritor front non-drive steer axles with unitized hubs.

Figure 13.10. Also included on the tag are the customer number, axle assembly plant and serial number.

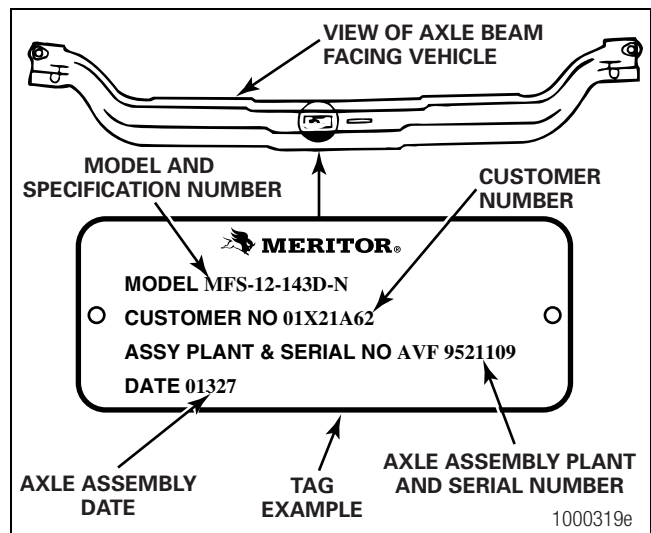

Figure 13.10

A unitized hub may also be referred to as a truck hub unit, Easy Steer Plus™ or a unitized hub. However, if a hubcap is embossed with “half moons,” it’s a unitized hub.

Meritor Axles Equipped with Unitized Hubs

Table DC: Model Numbers

| | | |
|---------------|---------------|--------|
| MFS-10-143D-N | MFS-12-144D-N | FF-983 |
| MFS-10-144D-N | MFS-13-144D-N | FF-984 |
| MFS-12-122D-N | FF-981 | FF-986 |
| MFS-12-143D-N | FF-982 | FF-987 |

Model Nomenclature

Refer to Figure 13.2 and Figure 13.3 for an explanation of axle model numbers.

Inspection Procedure

WARNING

YOU MUST FOLLOW THE UNITIZED WHEEL-END MAINTENANCE AND INSPECTION PROCEDURES PROVIDED IN THIS MANUAL TO PREVENT SERIOUS PERSONAL INJURY AND DAMAGE TO COMPONENTS.

- UNITIZED WHEEL ENDS ARE NOT ADJUSTABLE.
- DO NOT ATTEMPT TO SET OR ADJUST END PLAY.

To prevent serious eye injury, always wear safe eye protection when you perform vehicle maintenance or service.

Park the vehicle on a level surface. Block the wheels to prevent the vehicle from moving. Support the vehicle with safety stands. Do not work under a vehicle supported only by jacks. Jacks can slip and fall over. Serious personal injury and damage to components can result.

Take care when you use Loctite® adhesive to avoid serious personal injury. Read the manufacturer’s instructions before using this product. Follow the instructions carefully to prevent irritation to the eyes and skin. If Loctite® adhesive material gets into your eyes, follow the manufacturer’s emergency procedures. Have your eyes checked by a physician as soon as possible

When you apply some silicone gasket materials, a small amount of acid vapor is present. To prevent serious personal injury, ensure that the work area is well-ventilated. Read the manufacturer’s instructions before using a silicone gasket material, then carefully follow the instructions. If a silicone gasket material gets into your eyes, follow the manufacturer’s emergency procedures. Have your eyes checked by a physician as soon as possible.

Inspection Intervals

Refer to these inspection and maintenance procedures for Meritor axles equipped with unitized wheel ends on front non-drive steer axles. You must perform detailed and basic inspections at the following intervals.

Detailed Inspections

Refer to the procedure in this section.

- After the initial 200,000 miles (321 800 km) of operation
- After every additional 200,000 miles (321 800 km) of operation thereafter

Basic Inspections

After the initial 200,000-mile (321 800 km) detailed inspection, perform a basic inspection at each scheduled preventive maintenance interval, not to exceed 50,000-mile (80 467 km) intervals. Refer to the procedure in this section.

If the Vehicle is Equipped with ABS on the Steer Axle

In addition to the scheduled preventive maintenance, if the driver reports indicate the ABS light has been coming on, and ABS diagnostics indicate the sensor gap is out-of-adjustment, check for possible wheel-end looseness as the cause.

Tools Required

Basic Inspection

A jack, wheel blocks and safety stands

Detailed Inspection

A dial indicator and a torque wrench with 700 lb-ft (949 N•m) capability

13 Wheel Bearings and Wheel Ends

Basic Inspection

The unitized wheel end is sealed and greased for life and does not require lubrication. If you disassemble, or attempt to repair or lubricate a unitized wheel-end assembly, you will void Meritor's warranty. The basic inspection procedures do not instruct you to disassemble the unitized wheel end.

- Unitized wheel ends are not adjustable.
 - Do not attempt to set or adjust end play.
1. Park the vehicle on a level surface. Block the rear wheels to prevent the vehicle from moving.
 2. Raise the vehicle so that the front wheels are off the ground. Support the vehicle with safety stands. Do not use a jack to support the vehicle.

NOTE: If a ticking sound is detected during rotation, this does not indicate a hub problem. It is a normal occurrence.

3. Visually inspect the unitized wheel end as you rotate the tire and unitized wheel-end assembly. Verify that it rotates smoothly and without noise. While rotating the wheel, grasp the brake chamber to feel for unitized wheel-end hub vibration.
 - **If the tire and unitized wheel-end assembly does not rotate smoothly, or you hear noise (such as wheel bearing grind) or feel wheel-end hub vibration during rotation:** Perform a detailed inspection. Refer to the procedure in this section.
 - **If the wheel end rotates smoothly:** Proceed to the next step.
4. Grasp the tire and wheel-end assembly at the nine and three o'clock positions. Check for vertical and horizontal movement. With your hands, apply approximately 50 lb (23 kg) of force to the assembly. You should not feel or see any looseness or movement.
 - **If you feel or see any movement or looseness in the tire and wheel-end assembly:** Perform a detailed inspection to determine the cause of the movement, such as worn king pin bushings or pins; wheel-to-hub-mounting end play; unitized wheel-end hub end play; or a combination of them all. To determine unitized wheel-end hub end play, refer to the procedure in this section.

If other front axle components, such as king pin bushings, require inspection or service, refer to Maintenance Manual 2, Front Non-Drive Steer Axles. To obtain this publication, refer to the Service Notes page on the front inside cover of this manual.

To Help Determine the Cause of Wheel-End Assembly Looseness or Movement

1. Check the wheel-to-hub mounting. Verify that the wheel is mounted correctly and all wheel-end fasteners and hardware are tightened to the correct specification.
2. Apply the service brake to lock the hub and spindle assembly together.
 - **If you detect movement or looseness:** The king pin or king pin bushings should be inspected. Refer to Maintenance Manual 2, Front Non-Drive Steer Axles. To obtain this publication, refer to the Service Notes page on the front inside cover of this manual.
 - **If applying the service brake eliminates movement or looseness:** Proceed to the procedure in this section to determine the unitized wheel-end hub end play.

Detailed Inspection

The unitized wheel end is sealed and greased for life and does not require lubrication. If you disassemble, or attempt to repair or lubricate a unitized wheel-end assembly, you will void Meritor's warranty. The detailed inspection procedures provided in this section do not instruct you to disassemble the unitized wheel end.

- Unitized wheel ends are not adjustable.
 - Do not attempt to set or adjust end play.
1. Park the vehicle on a level surface. Block the rear wheels to prevent the vehicle from moving.
 2. Remove the hubcap.
 3. Raise the vehicle so that the front wheels are off the ground. Support the vehicle with safety stands. Do not use a jack to support the vehicle.
- NOTE:** The outboard and inboard seals may purge small amounts of grease that are visible during inspection. Figure 13.11. This is a normal occurrence.
4. Remove the wheel and drum. Attach the magnetic base of a dial indicator to the end of the spindle. Figure 13.12. Touch the indicator stem perpendicular against the unitized wheel end's mounting face.

13 Wheel Bearings and Wheel Ends

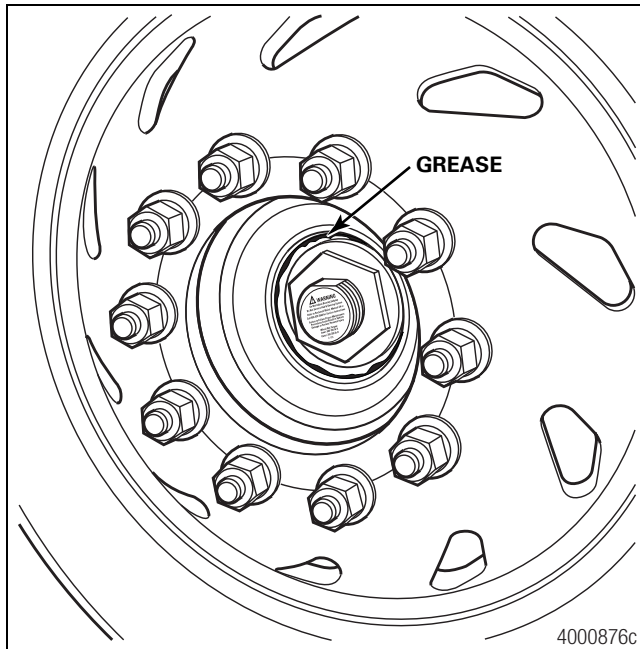

Figure 13.11

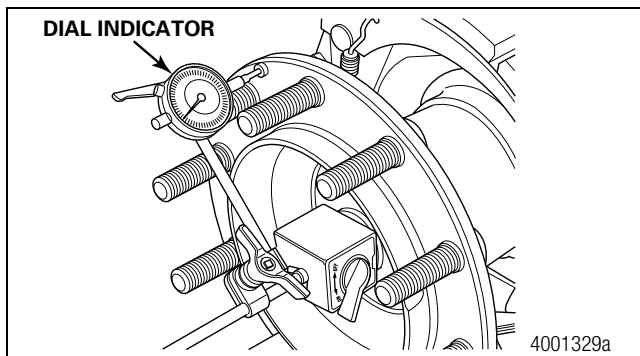



Figure 13.12

5. Set the dial indicator to ZERO. Do not rotate the wheel end. Place your hands at the nine and three o'clock positions.
6. Push the unitized wheel end straight IN. Note the reading. Pull the unitized wheel end straight OUT. Note the reading.
 - **If the total movement of the dial indicator is less than 0.003-inch (0.08 mm):** Inspection is complete. No adjustment is required.
 - **If the total movement of the dial indicator is 0.003-inch (0.08 mm) or greater:** Remove the outer bearing nut and tabbed washer. Tighten the inner wheel bearing nut to 500-700 lb-ft (679-949 N•m) while rotating the unitized wheel end a minimum of five rotations. Figure 13.13. 

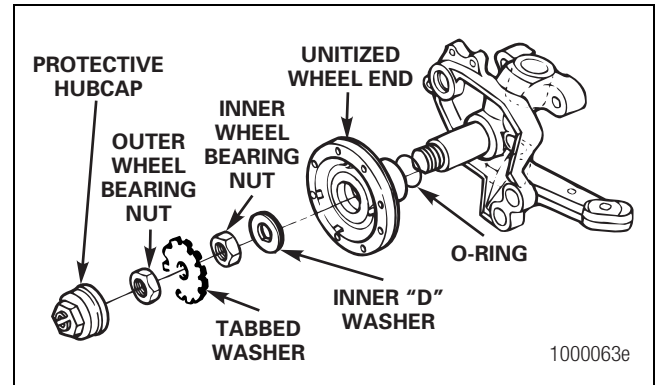



Figure 13.13

NOTE: The inner wheel bearing nut and the outer wheel bearing nut are identical, but the torque values are different.

7. Install the tabbed washer and outer wheel bearing nut onto the spindle.
 - For 1-1/8-inch (28.6 mm) wheel bearing nuts used on MFS-06, MFS-07 and MFS-08 Series axles: Tighten to 150-225 lb-ft (203-305 N•m). 
 - For other series axles: Tighten the outer wheel bearing nut to 200-300 lb-ft (272-408 N•m). 
8. Reattach the dial indicator. Set the dial indicator to ZERO. Do not rotate the wheel end. Place your hands at the nine and three o'clock positions.
9. Push the unitized wheel end straight IN. Note the reading. Pull the unitized wheel end straight OUT. Note the reading.
 - **If the total movement of the dial indicator is greater than 0.003-inch (0.08 mm), but less than 0.006-inch (0.15 mm):** Record the measurement in a maintenance log, and perform a basic inspection at the next regularly-scheduled maintenance interval, or not to exceed 50,000 miles (80 467 km), whichever comes first.
 - **If the total movement of the dial indicator is 0.006-inch (0.15 mm) or greater:** Replace the unitized wheel-end hub. You must inspect a replacement hub before you install it. Refer to the procedure in this section.
10. After you've taken the measurement, bend the parts of the tabbed washer that protrude over the flats of the outer wheel bearing nut and the inner wheel bearing nut. Bend the washer a minimum of one flat edge to each nut.

13 Wheel Bearings and Wheel Ends

NOTE: If a ticking sound is detected during rotation, this does not indicate a hub problem. It is a normal occurrence.

11. Verify that the unitized wheel end rotates smoothly and without noise. While rotating the wheel, grasp the brake chamber to feel for unitized wheel-end hub vibration.

- **If the unitized wheel-end assembly does not rotate smoothly, or you hear noise (such as wheel bearing grind) or feel wheel-end hub vibration during rotation:** Replace the unitized wheel-end hub. You must inspect a replacement hub before you install it. Refer to the procedure in this section.
- **If the wheel end rotates smoothly:** Inspection is complete. Reinstall the wheel-end equipment. Return the vehicle to service.

Replacement Hub Inspection

1. Remove the replacement hub from the box and place it on a clean surface.
2. Examine the interior of the hub to verify the following.
 - A. The inner clip ring has not become dislodged in shipment and is in correct alignment with the inner and outer bearings. The gap between the inner and outer bearing sets and the clip ring must be equal. Figure 13.14.
 - B. The gap between the ends of the clip ring must be equal and not exceed 0.25-inch (6 mm). If necessary, adjust by hand. Figure 13.14.

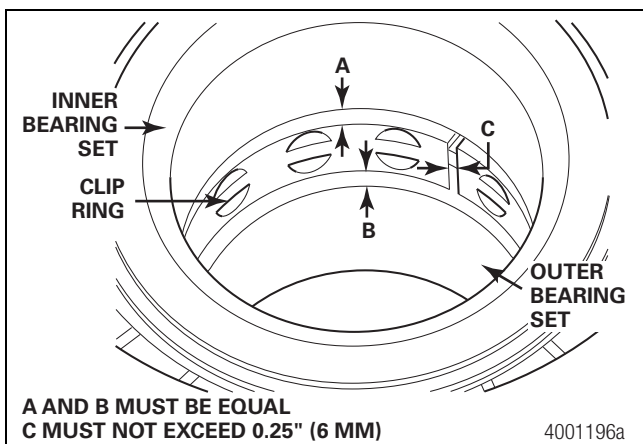

Figure 13.14

- C. The bearing face must be clean with no seal coating, dirt or dust.

3. Examine the exterior of the hub to verify the following.
 - A. There is no visible damage to the inboard or outboard seals and the bearings have not become unseated. Figure 13.15 and Figure 13.16.
 - B. The tone ring teeth are not damaged and there are no broken or missing teeth on the tone ring. Figure 13.16.

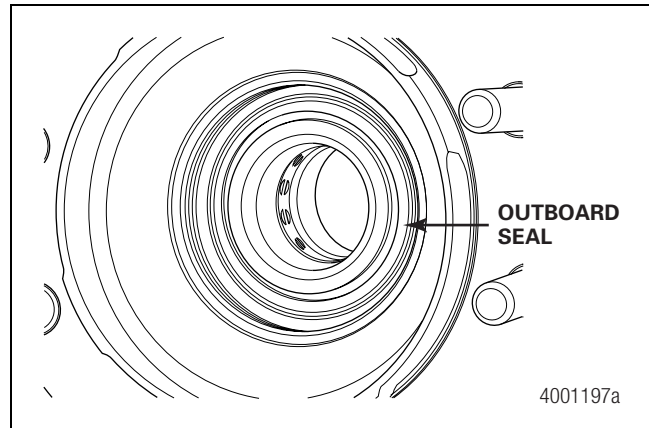

Figure 13.15

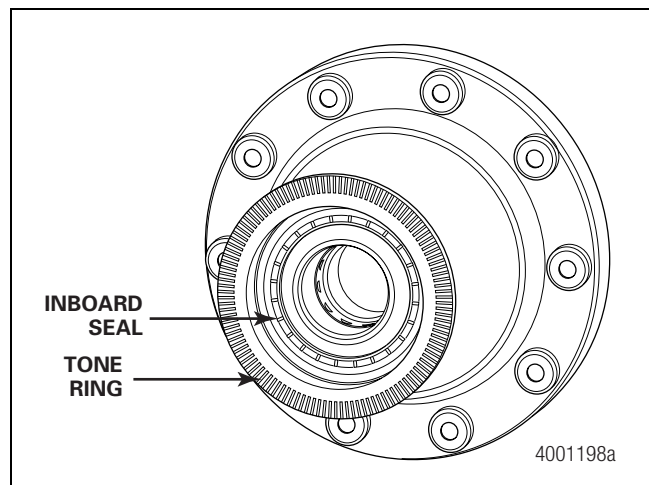

Figure 13.16

Install the Spindle O-Rings and Hubcaps

Refer to Maintenance Manual 2, Front Non-Drive Steer Axles, for procedures to install the spindle O-rings and hubcaps.

Unitized Wheel Ends on Bus and Coach FH Series Front and Tag Axles, and MC Series Rear Drive Axles

Certain Meritor bus and coach FH Series front and tag axle, and MC Series rear drive axle models are equipped with unitized wheel ends.

Unitized wheel-end components include a wheel adapter, rotor and unitized hub bearing mounted to a knuckle or spindle. There are two different spindle nut designs used on unitized wheel ends, double

nut pack and PRO-TORQ™ nut. They are different and not interchangeable. Figure 13.17, Figure 13.18 and Figure 13.19.

Wheel ends with unitized hub bearings are sealed and greased for life and do not require lubrication. These unitized wheel ends require periodic inspections to maintain performance.

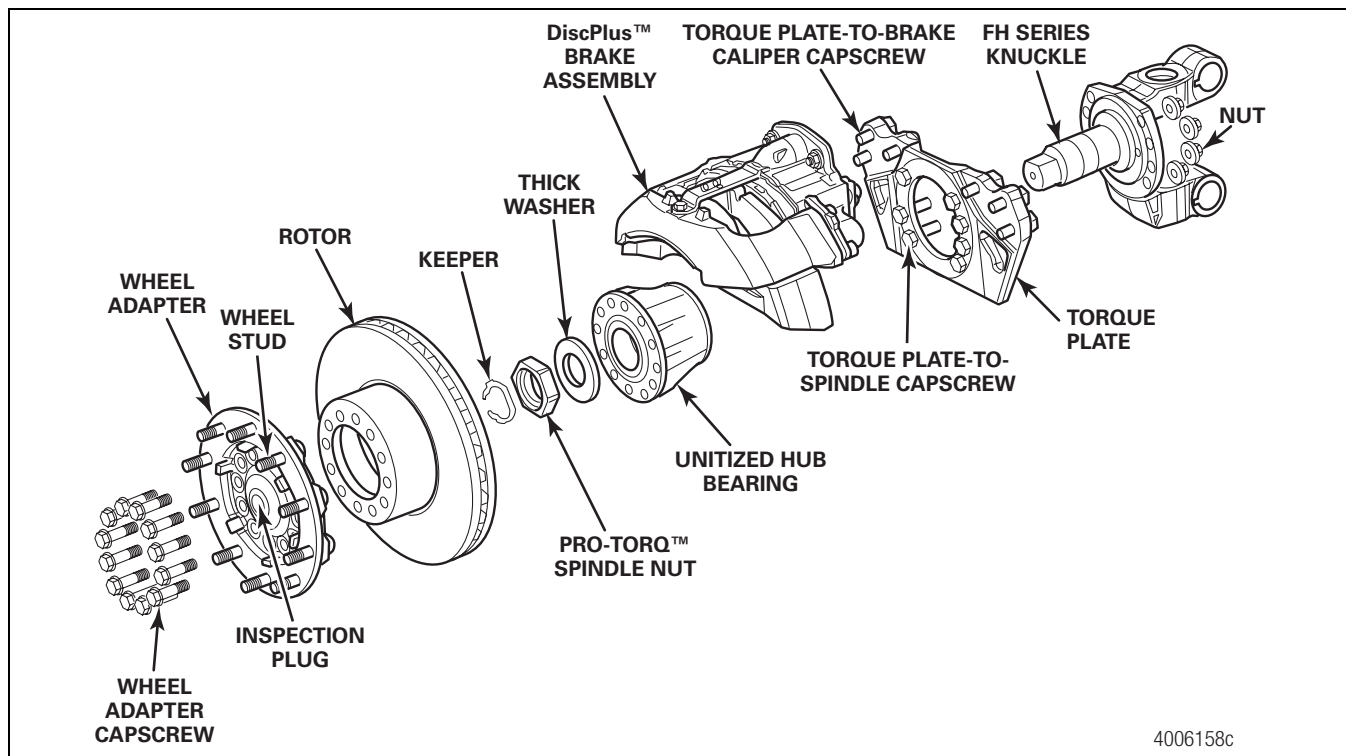

Figure 13.17

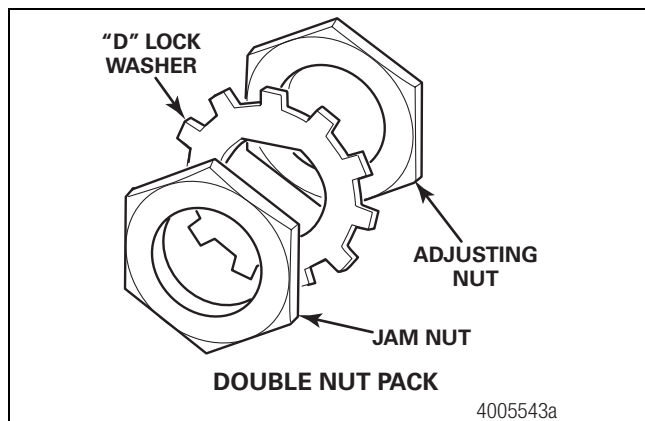

Figure 13.18

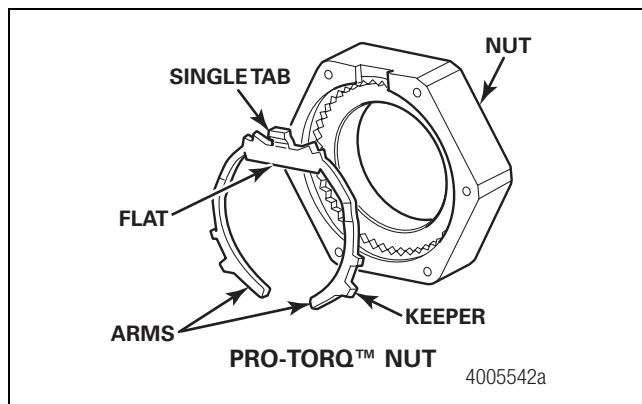

Figure 13.19

13 Wheel Bearings and Wheel Ends

Inspection

WARNING

The unitized wheel end is sealed and greased for life and does not require lubrication. If you disassemble, or attempt to repair or lubricate a unitized wheel-end assembly, you will void the Meritor warranty.

- Unitized wheel ends are not adjustable.
- Do not attempt to set or adjust the end play.

You must perform detailed and basic inspections at the following intervals. In addition to scheduled preventive maintenance, if driver reports indicate the ABS light has been coming on, and ABS diagnostics indicate the sensor gap is out of adjustment, check for possible wheel end looseness as the cause.

Detailed Inspections

- After the initial 100,000 miles (160 900 km) of operation or one year, whichever comes first
- After every additional 100,000 miles (160 900 km) of operation or one year, whichever comes first
- At mileages greater than 800,000 miles (1 287 480 km), after every six months or 50,000 miles (80 467 km), whichever comes first

Basic Inspections

- Perform a basic inspection between every two detailed inspections but not to exceed 50,000 miles (80 467 km) or six months of operation, whichever comes first.

Basic Inspection

1. Park the vehicle on a level surface. Block the rear wheels to prevent the vehicle from moving.
2. Raise the vehicle so that the inspected axle is off the ground. Support the vehicle with safety stands. Do not use a jack to support the vehicle.
3. Back off the brake caliper until the rotor is clear from the pad linings about 1/16-inch (1.588 mm) gap or more. Refer to Maintenance Manual MM-0467, DiscPlus™ EX225 Air Disc Brake, for more information about EX225 disc brake inspection and adjustment. To obtain this publication, refer to the Service Notes page on the front inside cover of this manual.

4. Visually inspect the unitized wheel end as you rotate the tire. Verify that it rotates smoothly and without noise.

If a clicking sound is detected during rotation, this does not indicate a hub problem. It is a normal occurrence.

While rotating the wheel, grasp the brake chamber to feel for unitized wheel-end hub vibration.

- **If the tire and unitized wheel-end assembly does not rotate smoothly, or you hear noise such as wheel bearing grind or feel wheel-end hub vibration during rotation:** Replace the unitized wheel-end hub.
- **If the wheel end rotates smoothly:** Proceed to Step 5.

5. Grasp the tire and wheel-end assembly at the nine and three o'clock positions. Check for vertical and horizontal movement. With your hands, apply approximately 50 lb (23 kg) of force to the assembly. You should not feel or see any looseness or movement.

- **If you feel or see any movement or looseness in the tire and wheel-end assembly:** Perform more inspections to determine the cause of the movement. Check for worn king pin bushings or pins; wheel-to-hub-mounting end play; unitized hub bearing end play; or a combination of them all. To determine unitized hub bearing end play, refer to the detailed inspection procedure in this section.

Wheel-to-Hub Mounting

Before proceeding with the detailed inspection, first check the wheel-to-hub mounting.

1. Verify that the wheel is mounted correctly and all wheel-end fasteners and hardware are tightened to the correct specification. Figure 13.20.

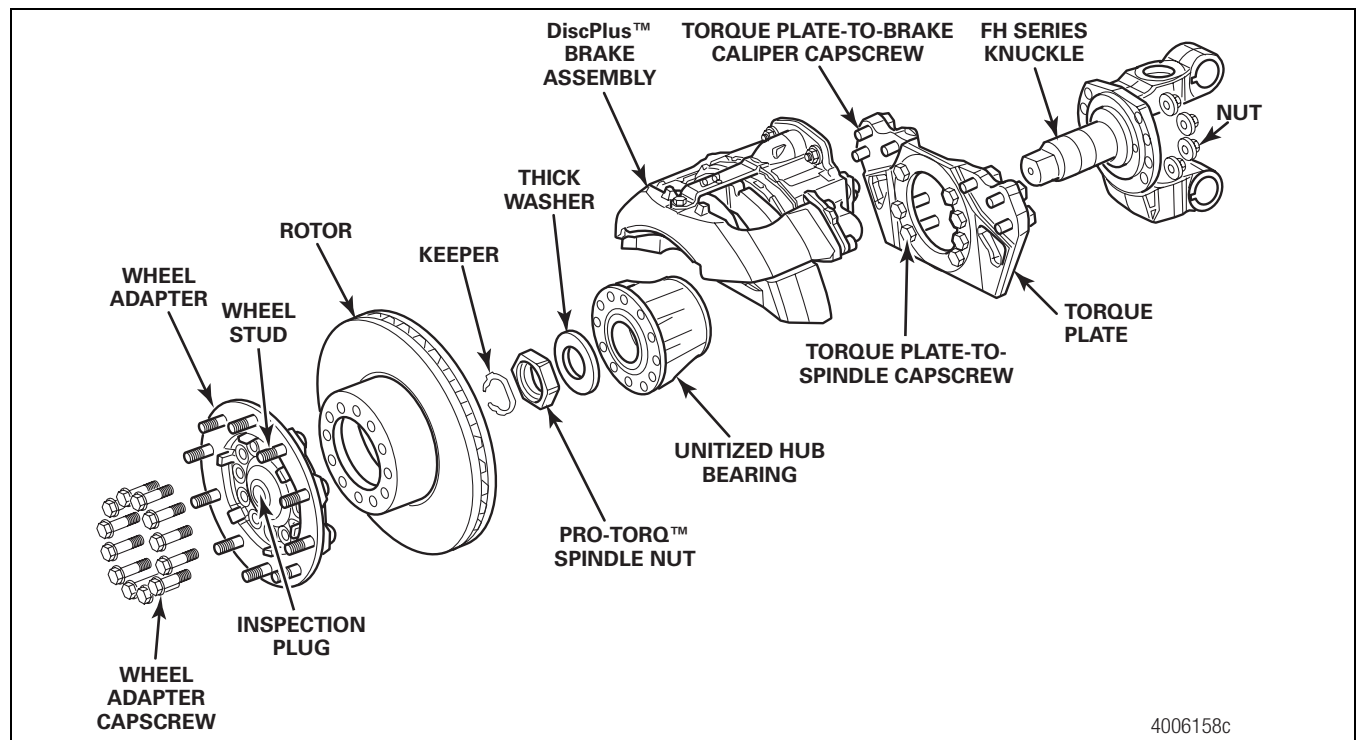

4006158c

Figure 13.20

13 Wheel Bearings and Wheel Ends

- Grasp the tire and wheel-end assembly at the nine and three o'clock positions. Check for vertical and horizontal movement. With your hands, apply approximately 50 lb (23 kg) of force to the assembly. You should not feel or see any looseness or movement.
 - If you detect movement or looseness on a tag axle:** Proceed to the Detailed Inspection.
 - If you detect movement or looseness on a front axle:** Inspect the king pin, bushings and seals for wear, leakage or damage. Refer to the procedures in Maintenance Manual 23, Bus and Coach Front Axles. To obtain this publication, refer to the Service Notes page on the front inside cover of this manual.
 - If applying the service brake eliminates movement or looseness:** Proceed to the detailed inspection procedures to determine the unitized hub bearing end play.

Detailed Inspection

- Park the vehicle on a level surface. Block the rear wheels to prevent the vehicle from moving.
- Raise the vehicle so that the inspected axle is off the ground. Support the vehicle with safety stands. Do not use a jack to support the vehicle.
- Back off the brake caliper until the rotor is clear from the pad linings about 1/16-inch (1.588 mm) gap or more. Refer to Maintenance Manual MM-0467, DiscPlus™ EX225 Air Disc Brake, for more information about EX225 disc brake inspection and adjustment. To obtain this publication, refer to the Service Notes page on the front inside cover of this manual.
- Verify that the unitized wheel end rotates smoothly and without noise.

If a clicking sound is detected during rotation, this does not indicate a hub problem. It is a normal occurrence.

While rotating the wheel, grasp the brake chamber to feel for unitized wheel-end hub vibration.

- If the tire and unitized wheel-end assembly does not rotate smoothly, or you hear noise such as wheel bearing grind or feel wheel-end hub vibration during rotation:** Replace the unitized hub bearing. Inspect the unitized hub bearing before installing it. Refer to the new hub inspection procedure in this section.
 - If the wheel end rotates smoothly:** Proceed to Step 5.
- Use a 5/16-inch drive tool to remove the pipe plug at the center of the wheel adapter. Install and tighten the adapter fitting into the hole.

- Attach the dial indicator. Loosen the locking set screw and slowly slide the dial indicator through the fitting hole. Position the dial indicator against the hub face and tighten the locking set screw as the needle starts moving. Set the dial indicator to ZERO. Do not rotate the wheel end. Figure 13.21.

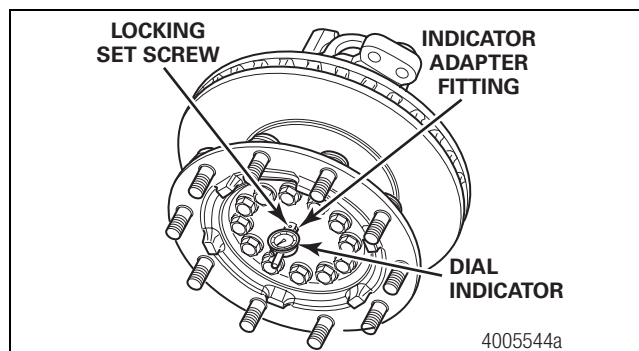



Figure 13.21

- Place your hands on the wheel hub at the nine and three o'clock positions. Push the wheel end straight IN. Note the reading. Then pull the wheel end straight OUT. Note the reading. The difference between the first and second readings is the total bearing end play.

Take at least two readings to obtain a correct end play measurement.

- If the total movement of the dial indicator is 0-0.002-inch (0.05 mm):** The inspection is complete. Go to Step 8.
 - If the total movement of the dial indicator is greater than 0.002-inch (0.05 mm) but less than 0.004-inch (0.1 mm):** Check and retighten the spindle nut to specifications. Set the dial indicator to ZERO and measure the end play again. Take at least two readings and record the measurement in a maintenance log. Perform another detailed inspection at the next regularly-scheduled maintenance interval, or up to 50,000 miles (80 467 km), whichever comes first.
 - If the total movement of the dial indicator is equal to or greater than 0.004-inch (0.1 mm):** Replace the unitized hub bearing as soon as possible. The unitized hub bearing may not be safe to operate.
- Remove the dial indicator and adapter fitting.
 - Apply a thin coat of sealant to the pipe plug threads. Install it into the wheel adapter and tighten it to a minimum of 15 lb-ft (20.34 N•m). 

Disassemble the Unitized Wheel End

⚠️ WARNING

You must follow the unitized wheel-end maintenance and inspection procedures provided in this manual to prevent serious personal injury and damage to components.

The unitized wheel end is sealed and greased for life and does not require lubrication. If you disassemble, or attempt to repair or lubricate a unitized wheel-end assembly, you will void the Meritor warranty.

⚠️ CAUTION

There are two different spindle nut designs used on unitized wheel ends, double nut pack and PRO-TORQ™ nut. They are different and not interchangeable. You must replace components with the same type and follow the correct tightening procedure for the nut system used to prevent damage to components.

Models with a Double Nut Pack

1. Park the vehicle on a level surface. Block the rear wheels to prevent the vehicle from moving.
2. Raise the vehicle so that the axle is off the ground. Support the vehicle with safety stands. Do not use a jack to support the vehicle.
3. Remove the brake caliper assembly. Refer to Maintenance Manual MM-0467, DiscPlus™ EX225 Air Disc Brake. To obtain this publication, refer to the Service Notes page on the front inside cover of this manual.
4. Remove the wheel adapter and rotor. Inspect the rotor for cracks and signs of wear. Replace the rotor if necessary. Figure 13.22.

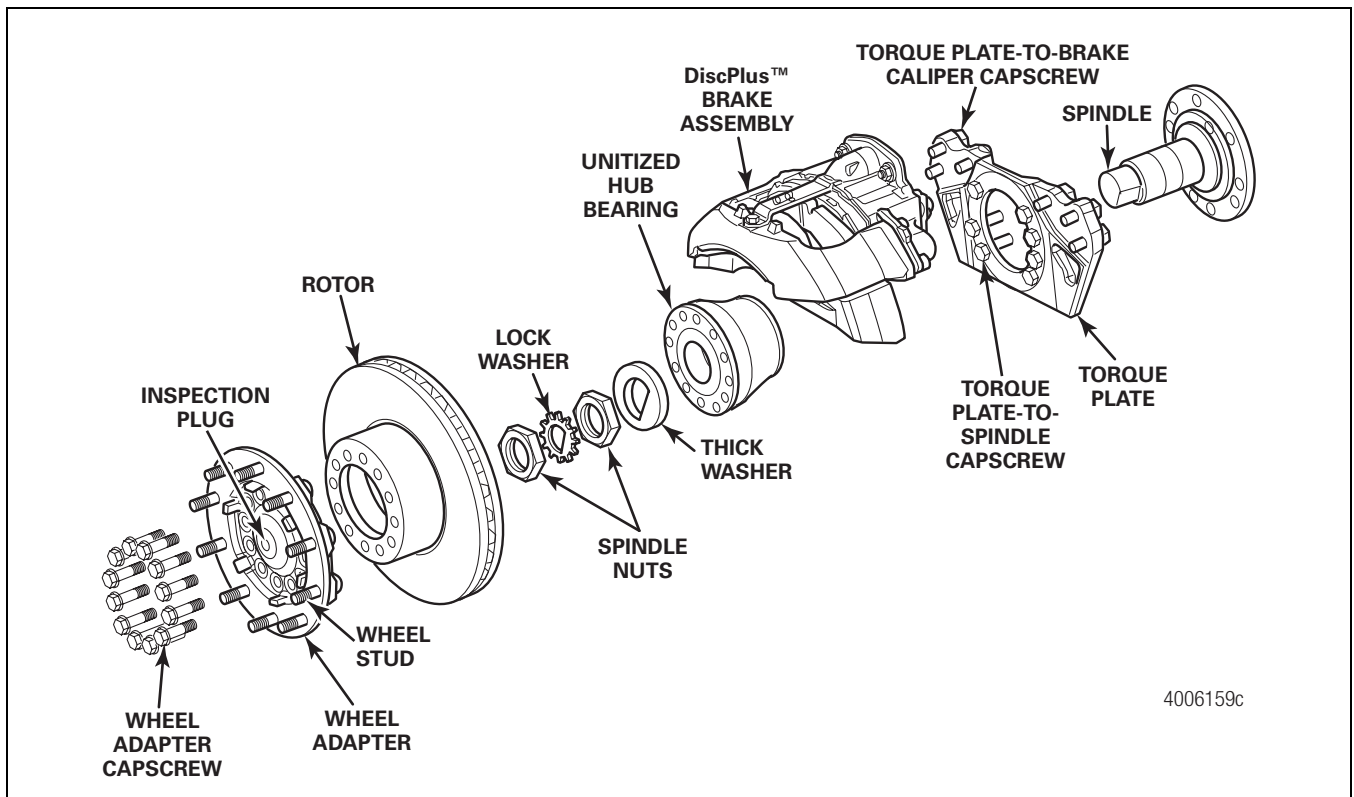

Figure 13.22

13 Wheel Bearings and Wheel Ends

5. Use a 3.5-inch (89 mm) socket wrench to remove the jam nut, "D" lock washer and adjusting nut. Figure 13.23.

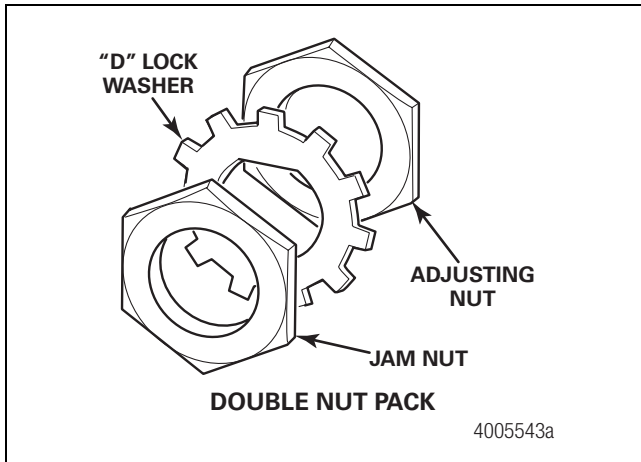

Figure 13.23

Models with a PRO-TORQ™ Nut

1. Park the vehicle on a level surface. Block the rear wheels to prevent the vehicle from moving.
2. Raise the vehicle so that the axle is off the ground. Support the vehicle with safety stands. Do not use a jack to support the vehicle.
3. Remove the brake caliper assembly. Refer to Maintenance Manual MM-0467, DiscPlus™ EX225 Air Disc Brake. To obtain this publication, refer to the Service Notes page on the front inside cover of this manual.
4. Remove the wheel adapter and rotor. Inspect the rotor for cracks and signs of wear. Replace the rotor if necessary. Figure 13.24.

6. Remove the thick washer and unitized hub bearing.

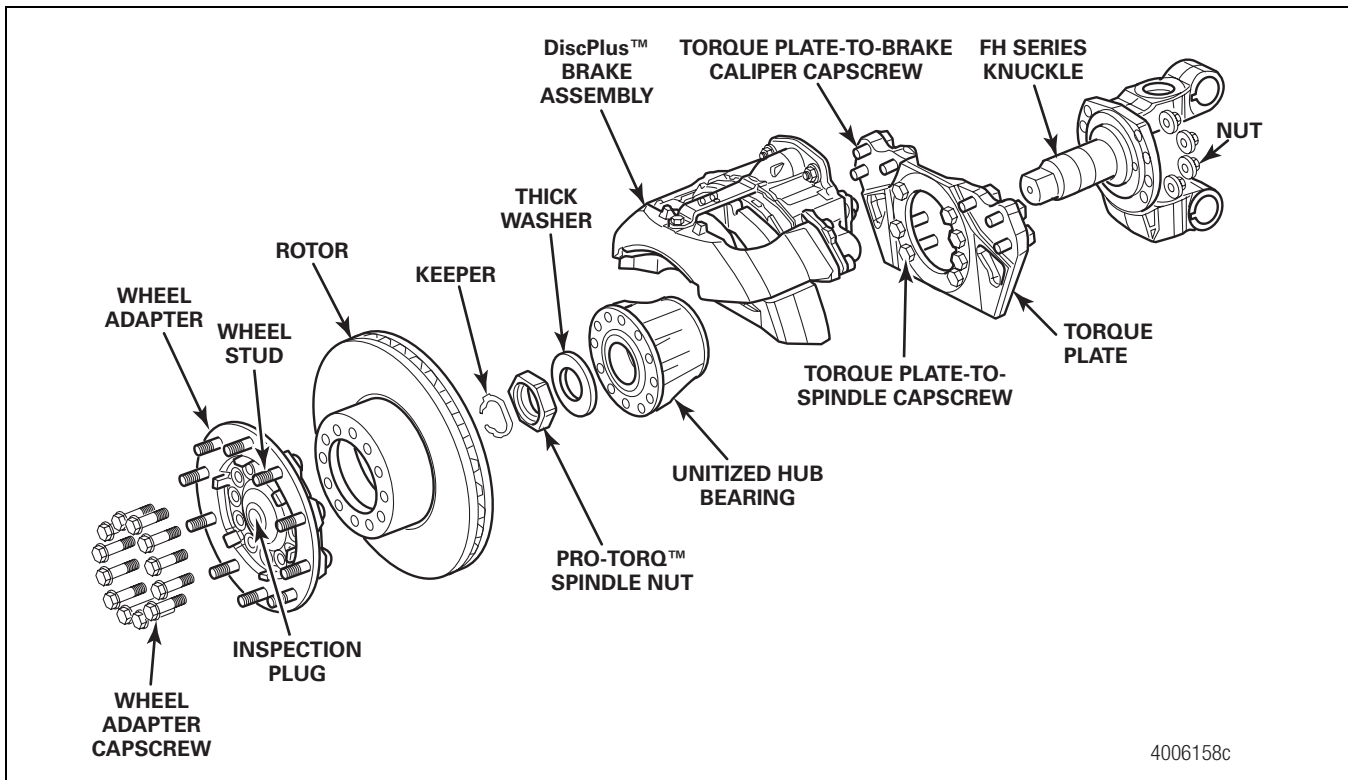

Figure 13.24

⚠ CAUTION

Remove the keeper from the PRO-TORQ™ nut before you attach the nut to the axle spindle, or tighten and loosen the nut, to prevent damage to the nut and axle spindle.

- Remove the keeper from the PRO-TORQ™ nut. Use a screwdriver to pry out the keeper arm from the groove on each side of the nut until the keeper is released. Meritor recommends replacing the keeper with a new one each time the PRO-TORQ™ nut is removed to maintain the integrity of the locking mechanism. Use a 3.5-inch (89 mm) socket wrench to remove the PRO-TORQ™ nut. Figure 13.25.

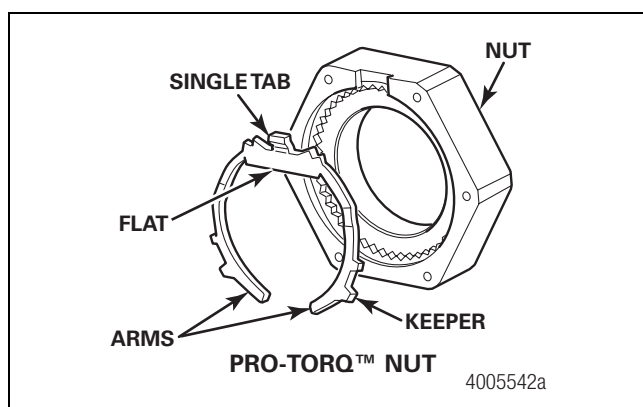

Figure 13.25

- Remove the thick washer and unitized hub bearing.

Trailer Axles with Long-Life Wheel Ends

The TB and TL Series trailer axles feature a permanently-sealed and lubricated unitized wheel-end assembly designed to help reduce wheel-end maintenance.

The unitized wheel end is designed to remain in place on the axle for a minimum of five years or 500,000 miles (800 000 km).

On a unitized wheel end, you install the hub, seal, lubricant and bearings onto the axle spindle as an assembly. Figure 13.26.

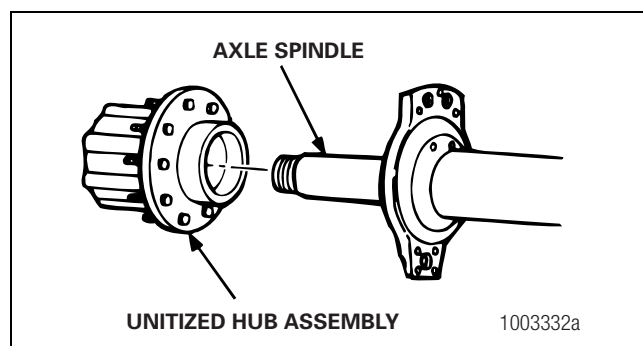

Figure 13.26

For TB Series unitized wheel-end service procedures, refer to Maintenance Manual MM-0420, Trailer Axles with Unitized Wheel Ends. To obtain this publication, refer to the Service Notes page on the front inside cover of this manual.

13 Wheel Bearings and Wheel Ends

Model Nomenclature

Refer to Figure 13.27 for an explanation of axle model numbers.

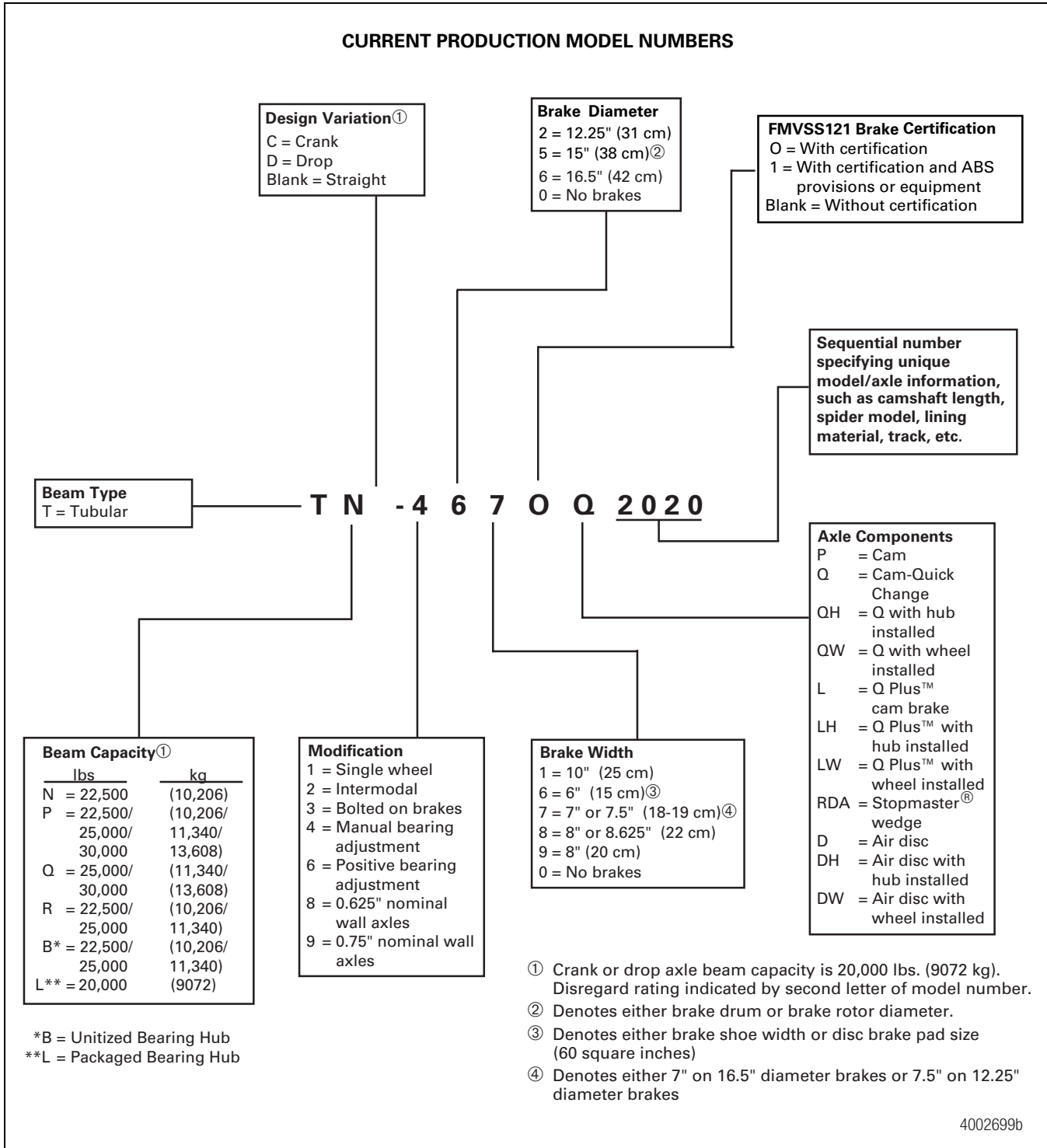

Figure 13.27

TB Series Trailer Axles with Unitized Hub Assemblies

TB Series trailer axles with unitized hub assemblies can be identified by the following features.

- The model number designation for the TB Series is prefixed with TB; for example, TB-4670 or TB-8670.
- The axle spindles are shorter with a single journal.
- The hubs contain non-serviceable bearings, seals and lubricant.
- The hubcaps screw onto the axle spindle and have no provisions for adding lubricant.
- The axle spindle retention hardware features a thicker inner nut and a bendable tab lock washer.
- Warranty information is stamped on each unitized wheel-end hubcap.

Removal of long-life bearings, seals or lubricant from the Meritor TB Series trailer axle unitized hub assembly will void the warranty. Refer to publication TP-96175, Servicing Meritor's TB Series Trailer Axles with Unitized Hub Assemblies, or call ArvinMeritor's Customer Service Center at 800-535-5560 for information.

Inspection and Maintenance

NOTE: Do not attempt to rebuild the hub. There are no serviceable components in the hub assembly.

1. Inspect the unitized hub for smooth rotation at each brake reline.
2. Inspect the unitized hub for smooth rotation and correct end play every year or 100,000 miles (160 934 km), whichever comes first.

Smooth Hub Rotation

1. Rotate the hub in both directions.
2. If the bearing feels rough or sounds noisy, replace the hub.

Hub End Play

1. Attach the magnetic base of a dial indicator to the end of the axle spindle and touch the dial indicator stem against the hub. Figure 13.28.

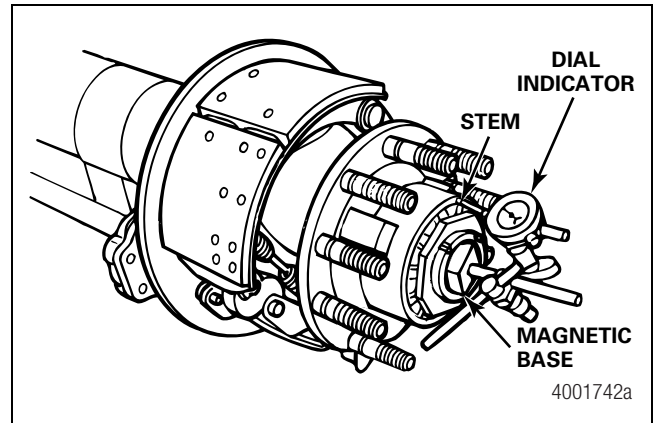

Figure 13.28

2. Push the hub INWARD until the dial indicator does not change. Set the dial indicator to ZERO. Figure 13.29.

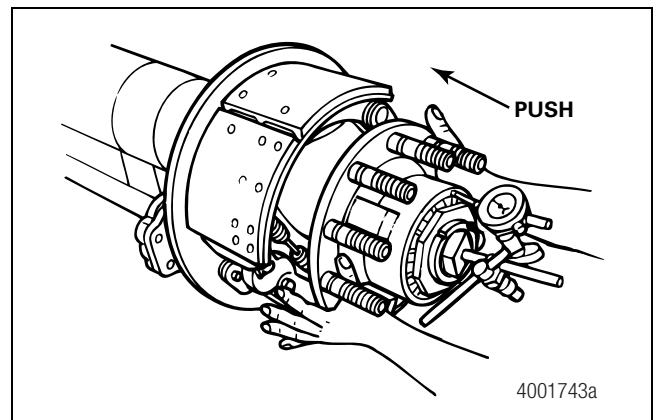

Figure 13.29

3. Pull OUTWARD until the dial indicator does not change. Figure 13.30. The difference between pushing INWARD and pulling OUTWARD is end play.
 - **If wheel bearing end play is less than 0.003-inch (0.0762 mm):** The adjustment procedure is complete. No further action is required.
 - **If wheel bearing end play is 0.003-inch (0.0762 mm) or more:** Retighten the wheel bearing adjusting nut and recheck the end play.
 - **If wheel bearing end play is 0.006-inch (0.1524 mm) or more:** Replace the unitized hub.

13 Wheel Bearings and Wheel Ends

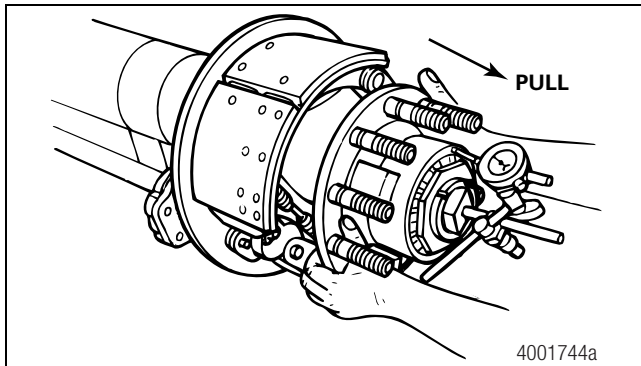

Figure 13.30

Seal Leaks

Check the back of the hub for a seal leak. The hub incorporates a grease seal. A leak of this seal will appear like that in a conventional wheel end. Figure 13.31.

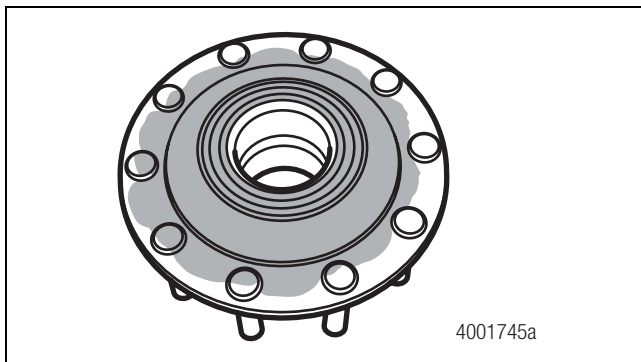

Figure 13.31

During hub installation, a small amount of grease will appear at the spindle back-up collar to hub joint. This is normal and does not indicate a seal leak. Figure 13.32.

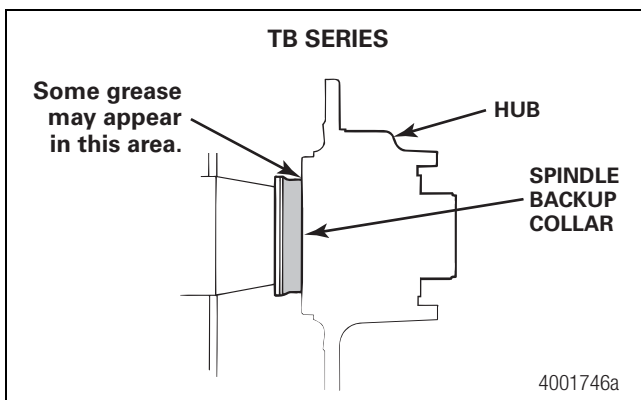

Figure 13.32

Small amounts of grease may be visible at the hub's outer seal. This is a normal occurrence and does not indicate a seal leak. However, if a large amount of grease is visible, the seal is leaking. Replace the hub. Figure 13.33.

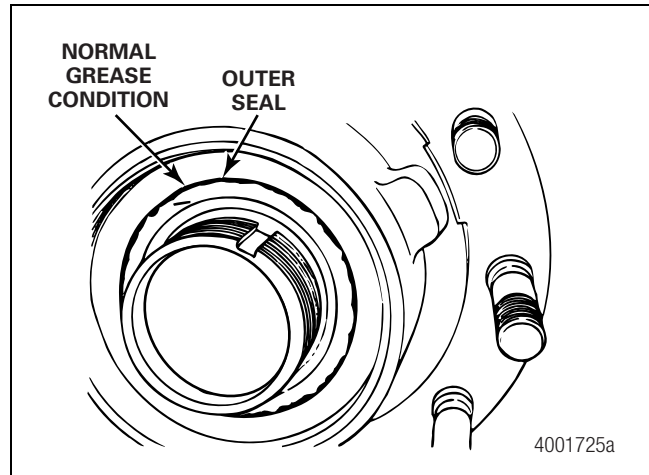

Figure 13.33

TL Series Trailer Axles with Packaged Bearing Hub Assemblies

The TL Series trailer axles with packaged bearing hub assemblies can be identified by the following features.

- The packaged bearing hub assembly has a metal hubcap secured by capscrews. "Half moons" are embossed in the center of the hubcap.
- The trailer axle identification tag shows TL at the beginning of the model number.
- The axle spindle is a "barrel" design.
- Warranty and service information are included on the hubcap.

Inspection Schedule

Check wheel bearing end play whenever a wheel end is off the ground, during a brake repair, when the hubcap or axle shaft is removed, when an ABS sensor "out of adjustment" fault occurs, or every 12 months or 100,000 miles (160 000 km), whichever comes first.

Inspect the packaged bearing hub assembly for smooth rotation every 100,000 miles (160 000 km) or 12 months, whichever comes first.

Inspect the packaged bearing hub assembly for smooth rotation at each brake reline. Rotate the hub in both directions. If the bearing feels rough or sounds noisy, replace the hub. If a large amount of grease is visible at the hub's outer seal, replace the hub.

Inspect the packaged bearing hub assembly for smooth rotation and movement if driver reports indicate that the anti-lock braking system (ABS) warning lamp comes on during operation, and ABS diagnostics indicate a gap exists between the wheel speed sensor and tooth wheel (sensor out-of-adjustment).

Inspection Procedure

WARNING

Park the vehicle on a level surface. Block the wheels to prevent the vehicle from moving. Support the vehicle with safety stands. Do not work under a vehicle supported only by jacks. Jacks can slip and fall over. Serious personal injury and damage to components can result.

1. Park the vehicle on a level surface. Block the wheels to prevent the vehicle from moving. Use a jack to raise the trailer until the tires are off the ground. Place safety stands under the trailer frame or axles. Do not use a jack to support the trailer.
2. Attach an air line to the trailer emergency glad hand connection.
 - **If the brake linings still touch the brake drums:** Use the automatic slack adjuster to manually back-off the brake shoes.

Check the Hub Assembly for Smooth Rotation and Noise

You can perform this procedure with or without the tire and wheel assembly installed.

1. Rotate the hub assembly and listen for bearing noise. Worn bearings make a low-pitch grinding sound. If the tire is installed, the wheel will amplify the noise.
2. Place your hand on the brake air chamber that services the wheel end. Feel for any bearing vibration as the hub assembly rotates. The air chamber will amplify bearing vibration. For example, if there's dirt in the hub seal, you may hear a noise similar to a worn bearing. In this case, rely more on vibration than noise.
 - **If you feel wheel bearing vibration or hear noise:** Check the wheel bearing end play.

Inspect the Inner and Outer Grease Seals for Leaks

When the hub assembly is installed, a small amount of grease may appear at the spindle backup collar-to-hub joint. This is a normal occurrence and does not indicate that a seal is leaking.

1. Inspect the hub assembly's inner grease seal for leakage. A leaking seal will stain the back of the hub with lubricant, a condition similar with a conventional hub.
 - **If the seal is leaking:** Replace the hub assembly.
2. Inspect the hub assembly's outer grease seal for leakage. A small amount of grease around the perimeter of the seal is a normal occurrence and doesn't indicate that the seal is leaking.
 - **If you find a large amount of grease on the entire surface of the seal and surrounding hub surfaces:** Replace the hub assembly.

13 Wheel Bearings and Wheel Ends

Trailer Lubrication Intervals and Specifications

Table DD: Camshaft Bushing and Slack Adjusters Greasing Intervals and Specifications

| Greasing Interval* | Grease | Meritor Specification | NLGI Grade | Grease Description | Outside Temperature |
|--|----------------------|-----------------------|------------|--|---|
| Use the schedule below that gives the most frequent lubrication. | Multi-Purpose Grease | 0-617-A or 0-617-B | 1 or 2 | Lithium 12-Hydroxy Stearate or Lithium Complex | Refer to the grease manufacturer's specifications for the temperature service limits. |

- The lubrication schedule of the fleet.
- The lubrication schedule of the vehicle manufacturer.
- A minimum of four times during the life of the brake linings.

* Applies to standard-duty on-highway service. Lubricate more frequently for heavy-duty applications. Determine intervals by inspecting the lubricant every two weeks for a four-month period. Look for hard, contaminated or missing grease. Choose an interval based on the inspection.

TRIAD™ Trailer Axle Wheel-End System

Installing Spindle Nuts on Trailer Axle Models TN, TQ and TP

Use the following procedure to install spindle nuts on trailer axle models TN, TQ and TP equipped with TRIAD™ trailer axle wheel ends.

Removal of the bearings, seals or lubricant from the hub voids the warranty.

1. Install the hardened washer against the outer bearing. Figure 13.34.

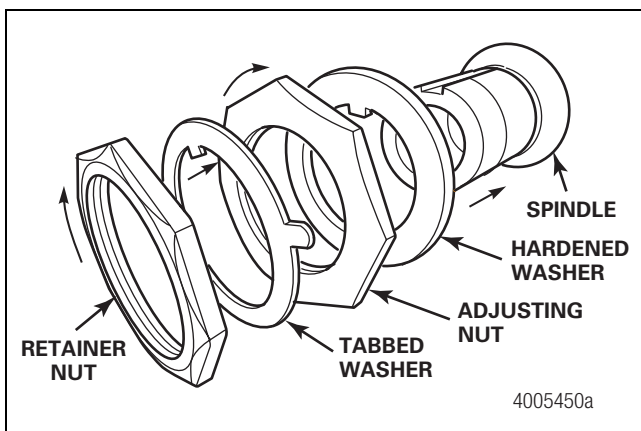

Figure 13.34

2. Install the adjusting nut against the hardened washer. Tighten the nut to 150-200 lb-ft (204-272 N•m) while rotating the wheel-end assembly. ⚙️
3. Completely loosen the adjusting nut. Tighten the nut to 25 lb-ft (34 N•m) while rotating the wheel-end assembly. ⚙️
4. Install the tabbed washer against the adjusting nut.
5. Install the retainer nut against the tabbed washer. Tighten the nut to 25 lb-ft (34 N•m). ⚙️
Align the tab with a flat surface of the retainer nut. If necessary, turn the nut COUNTERCLOCKWISE to align the closest flat with the tab.
6. Bend the washer tab OUTWARD over the flat surface of the retainer nut.
7. Apply 200-275 lb-ft (272-374 N•m) of torque to rotate the adjusting nut in a COUNTERCLOCKWISE direction and jam it against the tabbed washer and retainer nut. ⚙️

Wheel-End Equipment Checks

Studs and Nuts

The following warnings are to alert you to stud and nut conditions and maintenance procedures that can affect your safety and the integrity of the vehicle and its components.

Carefully read the warnings before you install disc wheels.

WARNING

Replace bent, loose, broken or stripped studs. When you replace a stripped stud, always replace the stud on each side of the stripped stud as well. Even if the adjoining studs are not cracked, they have sustained fatigue damage, which can cause the wheels to loosen and separate from the vehicle. Serious personal injury and damage to components can result.

Always replace a serrated stud, bolt, with a new one. Do not reuse a serrated stud, which will not tighten correctly and can cause the wheels to loosen, to separate from the vehicle. Serious personal injury and damage to components can result.

Do not apply paint to mounting surfaces, studs or nuts. Paint decreases a fastener assembly's capability to maintain clamp load, which can cause wheels to loosen and separate from the vehicle. Serious personal injury and damage to components can result.

Ensure that you do not damage the stud threads. Damaged threads will not allow the stud to provide the required clamp load to support the wheel retention system. The wheels can loosen and separate from the vehicle. Serious personal injury and damage to components can result.

Check that stud standout is correct for stud-piloted wheels. If standout exceeds specifications even though the correct torque is used, the cap nut can bottom against the hub stud and loosen both wheels and the brake drum, which will cause the wheels to separate from the vehicle. If standout is too short, the cap nut will overload and crack, causing the inner and dual wheels to separate from the vehicle. Serious personal injury and damage to components can result.

Install right-hand studs on the right side of the vehicle and left-hand studs onto the left side of the vehicle. Studs that are not installed correctly can loosen, which can cause the wheels to loosen and separate from the vehicle. Serious personal injury and damage to components can result.

Do not lubricate the studs or nut threads. Lubricants will not enable you to tighten the fasteners correctly, which causes excessive clamp load. The studs can break and cause the wheels to loosen and separate from the vehicle. Serious personal injury can result.

Do not install 1-1/2-inch hex two-piece flange nuts onto M22 x 1.5 serrated studs when 33 mm two-piece hex nuts are used on the CentroMount-8™ system. The wheels can crack, loosen and separate from the vehicle. Serious personal injury and damage to components can result.

Install aluminum wheel nuts onto an aluminum disc wheel. Do not install steel wheel nuts. Steel wheel nuts can damage an aluminum wheel or cause the dual wheels to loosen and separate from the vehicle. Serious personal injury and damage to components can result.

Install steel wheel nuts onto steel wheels. Do not install aluminum wheel nuts. The extension on an aluminum wheel nut can bottom against the hub flange or brake drum before the disc wheel is clamped correctly, which can cause the wheels to separate from the vehicle. Serious personal injury and damage to components can result.

Install the nuts with the correct thread size onto the studs. A nut with an incorrect thread size will not turn freely on the stud or will fit loosely on the stud. The thread can strip, which can cause loss of clamp load. The wheels can loosen and separate from the vehicle. Serious personal injury and damage to components can result.

Install the correct wheel system components for the application. Do not mix wheel system components. The wheels can loosen and separate from the vehicle. Serious personal injury and damage to components can result.

Add two drops of oil between the nut flange and the hex portion of the swivel area at each installation if you reinstall the two-piece flange nuts that have been in service. Without lubrication, the fasteners may not produce adequate clamp load, and the wheel(s) can loosen and separate from the vehicle. Serious personal injury and damage to components can result.

1. Check the studs. Repair or replace loose, bent, stripped or broken studs.
2. Check for correct serrated stud standout.
 - A. Figure 13.35 shows correct standout.
 - B. Figure 13.36 and Figure 13.37 show incorrect standout.

13 Wheel Bearings and Wheel Ends

- C. Serrated studs do not usually interchange with those in various hub part numbers. Check the application. Call ArvinMeritor's Customer Service Center at 800-535-5560 for more information.

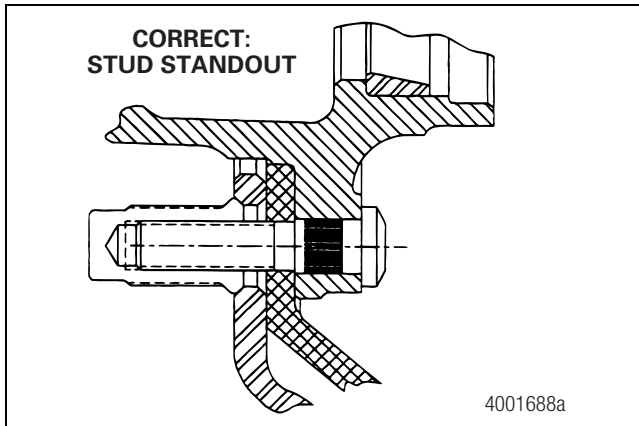

Figure 13.35

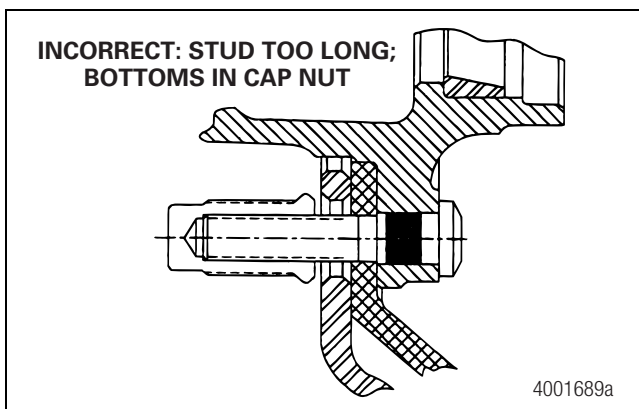

Figure 13.36

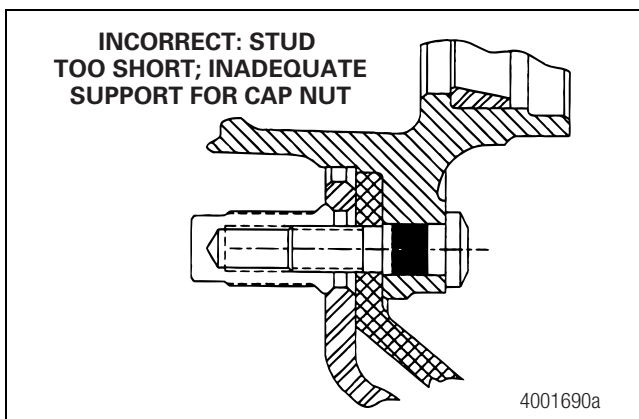

Figure 13.37

3. Check for **R** and **L** stamped in the end of the stud. Figure 13.38. Install right-hand studs onto the right side of the vehicle, and left-hand studs onto the left side of the vehicle.

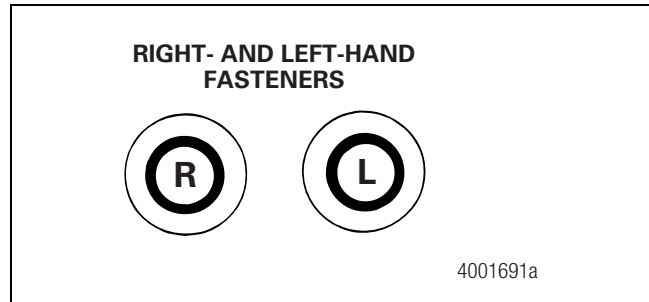

Figure 13.38

4. Some manufacturers color code studs. Check the manufacturer's instructions to verify the color code used.
5. Install the correct nut into all applications. Do not install rusty, galled or worn nuts. Ensure that you use the correct nuts in the following installations.
- Install 33 mm hex two-piece flange nuts into ISO 285.75 mm bolt circle diameter (BC) and ISO 335 mm BC systems.
 - Install 1-1/2-inch hex two-piece flange nuts into a 275 mm system with M22 x 1.5 serrated studs. Do not install 1-1/2-inch hex two-piece flange nuts onto M22 x 1.5 serrated studs when 33 mm two-piece hex nuts are used on the CentroMount-8™ system.
6. Install aluminum wheel nuts onto aluminum wheels. Do not install steel wheel nuts. An aluminum wheel nut has an extension to accommodate the thickness of the aluminum. Figure 13.39 and Figure 13.40.

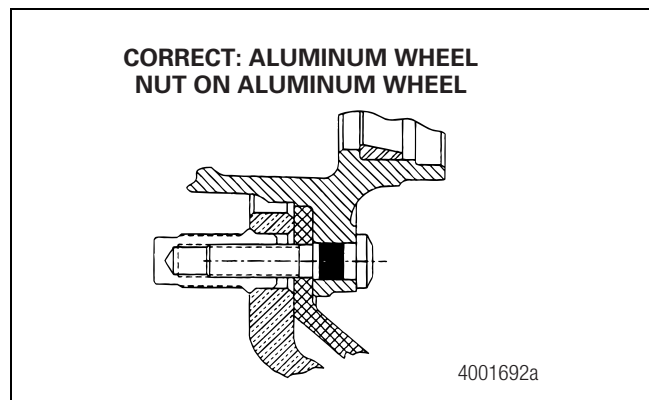

Figure 13.39

13 Wheel Bearings and Wheel Ends

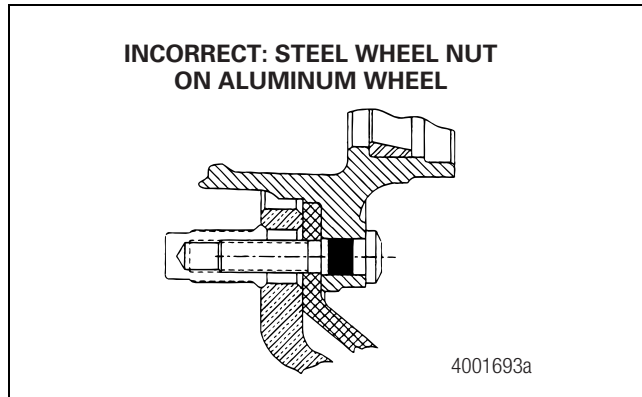

Figure 13.40

7. Install steel wheel nuts onto steel wheels. Do not install aluminum wheel nuts. The extension of the aluminum wheel nut can bottom against the hub flange or brake drum before the disc is clamped correctly. Figure 13.41 and Figure 13.42.

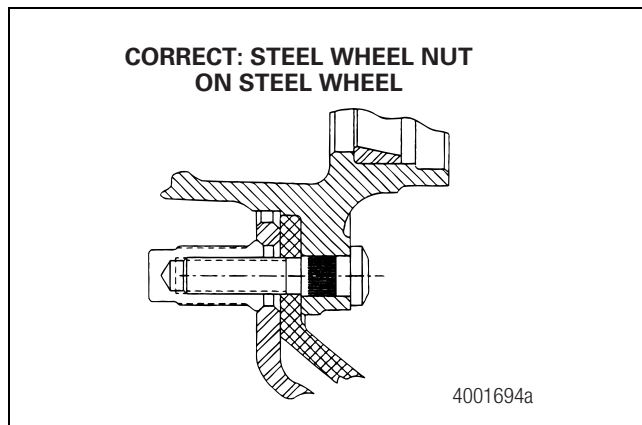

Figure 13.41

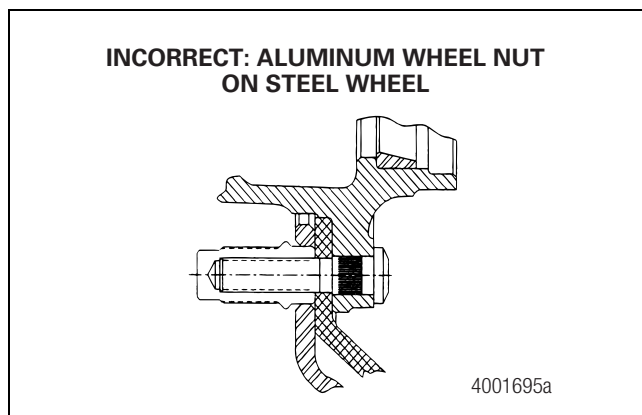

Figure 13.42

8. Install nuts with the correct thread size onto the studs. A correct thread size enables the nut to turn freely on the stud. An incorrect nut will fit very loosely on the stud thread, which can cause the thread to strip.
9. Check the extension of the stud through the nut after you tighten the nut to the specified torque.
 - **If less than two threads extend through the nut, or more than 3/8-inch (9.5 mm) of the stud extends through the nut:** Check all parts to verify that they are correct for the wheel system you will install on the vehicle.
10. Ensure that the nut and wheel mate correctly. Ensure that you install the correct components onto the wheel systems. Figure 13.43 and Figure 13.44.
 - **If the wheel has a ball seat bolt hole pattern:** The nut must have a spherical surface that seats in the ball seat.
 - **If the wheel has a cylindrical bolt hole pattern:** The nut must have a flat surface that seats against the wheel.

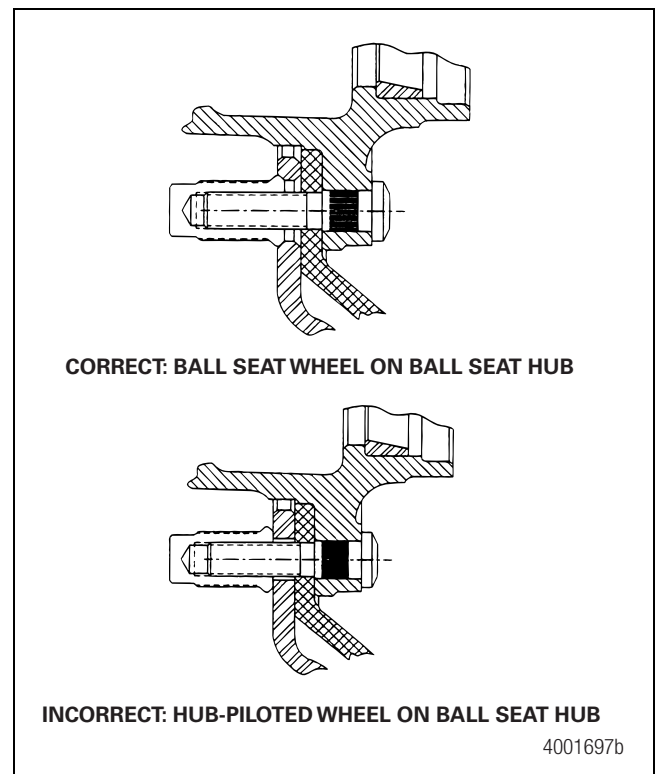

Figure 13.43

13 Wheel Bearings and Wheel Ends

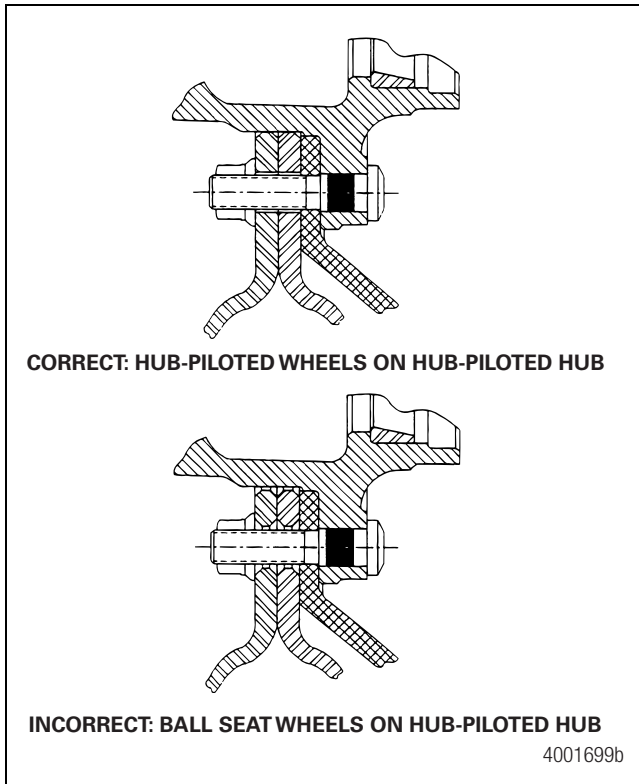

Figure 13.44

- Follow the disc wheel manufacturer's fastener tightening sequence when you install fasteners to help ensure a higher and more uniform clamp load. Figure 13.45. Always check fasteners at the wheel manufacturer's recommended service intervals.

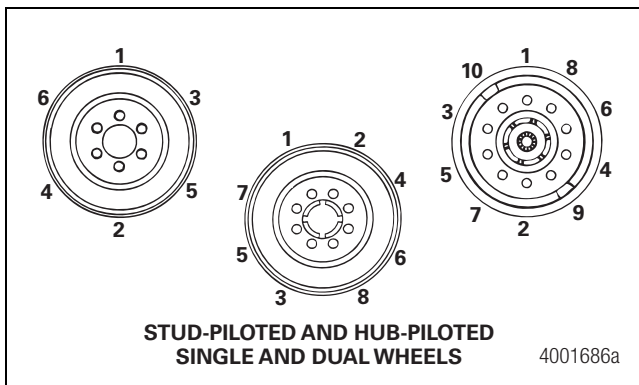

Figure 13.45

- Add two drops of oil between the nut flange and the hex portion of the swivel area at each installation if you reinstall the two-piece flange nuts that have been in service. Do not oil the stud or nut threads.
- Retighten all wheel nuts on all systems at 50-100 miles (80-160 km) to the correct torque specifications.
- Use the correct installation tools.
- Ensure that the gross weight does not exceed gross vehicle weight (GVW). Ensure that the axle loads do not exceed gross axle weight ratings (GAWR).

Installing Double-Ended Metric Wheel Studs with 3/4-16 and M22 x 1.5 Threads Onto Hub and Rotor Assemblies on Axles Equipped with Meritor Air Disc Brake Model ADB 1560

Important Note: The 390-450 lb-ft (529-610 N•m) torque specification provides sufficient clamp load to install a hub-piloted wheel on one end of the double-ended wheel stud and not exceed the torque capacity of the 3/4-16 threads on the opposite end. The wheel stud is a standard design and has been in production since 1987.

Use this specification rather than 450-550 lb-ft (610-746 N•m), which is usually specified when installing hub-piloted wheels.

Installation Procedure

⚠ ASBESTOS AND NON-ASBESTOS FIBERS WARNING

Some brake linings contain asbestos fibers, a cancer and lung disease hazard. Some brake linings contain non-asbestos fibers, whose long-term effects to health are unknown. You must use caution when you handle both asbestos and non-asbestos materials.

⚠ WARNING

Tighten the fasteners to the correct torque specifications. Do not over-tighten or under-tighten fasteners, which can cause the wheels to separate from the vehicle. Serious personal injury and damage to components can result.

- Tighten the inner 3/4-16 nuts to 100 lb-ft (136 N•m) to seat the wheel studs. Figure 13.46. **🔧**
- Tighten the outer M22 x 1.5 nuts to 390-450 lb-ft (529-610 N•m) to install the hub-piloted wheels. **🔧**

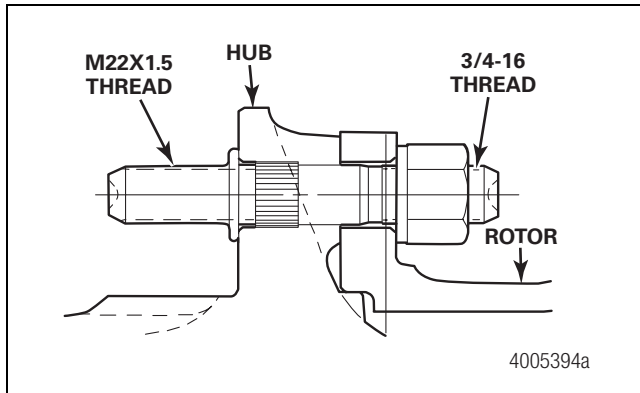

Figure 13.46

Vehicles Equipped with ABS

In addition to the scheduled preventive maintenance, if the driver reports indicate the ABS light has been coming on, and ABS diagnostics indicate the sensor gap is out-of-adjustment, check for possible wheel-end looseness as the cause.

14 Specifications

Lubrication Intervals and Specifications

Grease Lubricants

Table DE: Grease Lubricants*

| Meritor Specification | Grease | Typical Application | NLGI Grade | Grease Description | Outside Temperature |
|-----------------------|---|--|------------|---|-----------------------|
| 0-616 | Brake Grease | Cam Brake Anchor Pins, Mechanical Brake Anchor Pins | 2 | Clay Base | ¹ |
| 0-616-A | Brake Grease | Air Disc Brake Caliper, Automatic Slack Adjuster, Wedge Brake Components | 1 | Clay Base | Down to -40°F (-40°C) |
| 0-617-A or 0-617-B | Multi-Purpose Grease | Cam Brake Chamber Brackets, Cam Brake Hold Down Clips, Cross Tube Ends, Drag Link, Wheel Bearings, King Pins and Bushings, Knuckle Bushings, Manual Slack Adjuster, Steering Arm, Ball Studs, Tie Rod End Ball Studs, Trailer Axle Wheel Bearings, Wedge Brake Hold-Down Clips, Wedge Brake Shoe Contacts at Anchors | 1 or 2 | Lithium 12-Hydroxy Stearate or Lithium Complex | ¹ |
| 0-634-B | Universal Joint Grease | Driveshaft Slip Yokes, Driveshaft Splines, Driveshaft Universal Joints | 2 | Lithium 12-Hydroxy Stearate with Molybdenum Disulfide | ¹ |
| 0-637 ² | Special Rust-Preventing Brake Grease | Air Disc Brake Slide Pin, Splines and Clevis Pins, Cam Brake Camshaft Splines | 1-1/2 | Calcium | ¹ |
| 0-645 | Low-Temperature Brake Grease | Air Disc Brake Caliper, Automatic Slack Adjuster, Wedge Brake Components | 2 | Synthetic | Down to -65°F (-54°C) |
| 0-647 | Trailer Axle Bearing Grease | Trailer Axle Wheel Bearings | 00 | Synthetic | ¹ |
| 0-661 | High-Temperature Multi-Purpose Wheel Bearing Grease | Clutch Release Bearing | 3 | Lithium Complex | ¹ |
| 0-692 | Automatic Slack Adjuster Grease | Automatic Slack Adjuster | 1 and 2 | Lithium Base | Down to -40°F (-40°C) |

¹ Refer to the manufacturer's specifications for the temperature service limits.

² Do not mix 0-637 calcium-base, corrosion-control grease with other greases.

* Grease recommendations are based on commercial products that have given satisfactory results in normal operation. However, there are many proprietary grease products on the market which will perform satisfactorily and may be preferable because of supply problems, common usage for other truck components, etc. When such products are recommended by reputable suppliers for the specific lubrication of our components, Meritor has no objections, provided that these substitute products are equal to or better than Meritor recommendations in lubrication properties, water resistance, corrosion protection, high and low temperature characteristics, oxidation stability, shear stability, etc. All substitute products are subject to Meritor approval. For more information, contact an ArvinMeritor service representative.

Oil Lubricants

Table DF: Oil Lubricants

| Meritor Specification | Oil | Typical Application | Military/SAE Specifications | Oil Description | Outside Temperature | | | |
|--------------------------|--------------------|--|--------------------------------|------------------|---------------------|------|------|------|
| | | | | | °F | | °C | |
| | | | | | Min. | Max. | Min. | Max. |
| 0-62 | Petroleum Oil | Transfer Case | — | SAE 90 | -10 | None | -12 | None |
| 0-63 | Petroleum Oil | Transfer Case | — | SAE 140 | -40 | None | -4 | None |
| 0-76A | Gear Oil | Front Drive Axle, Front Drive Axle Wheel Bearings, Non-Drive Axle Wheel Bearings, Planetary Axle, Rear Drive Axle, Trailer Axle Wheel Bearings | MIL-PRF-2105-E and SAE J2360 | GL-5 SAE 85W/140 | -10 | None | -12 | None |
| 0-76D | Gear Oil | Front Drive Axle, Front Drive Axle Wheel Bearings, Non-Drive Axle Wheel Bearings, Planetary Axle, Rear Drive Axle, Trailer Axle Wheel Bearings | | GL-5 SAE 80W/90 | -15 | None | -26 | None |
| 076E | Gear Oil | Front Drive Axle, Front Drive Axle Wheel Bearings, Non-Drive Axle Wheel Bearings, Planetary Axle, Rear Drive Axle, Trailer Axle Wheel Bearings | | GL-5 SAE 75W/90 | -40 | None | -40 | None |
| 0-76J | Gear Oil | Front Drive Axle, Front Drive Axle Wheel Bearings, Non-Drive Axle Wheel Bearings, Planetary Axle, Rear Drive Axle, Trailer Axle Wheel Bearings | | GL-5 SAE 75W | -40 | 35 | -40 | 2 |
| 0-76L | Gear Oil | Front Drive Axle, Front Drive Axle Wheel Bearings, Non-Drive Axle Wheel Bearings, Planetary Axle, Rear Drive Axle, Trailer Axle Wheel Bearings | | GL-5 SAE 75W/140 | -40 | None | -40 | None |
| 0-76M | Full Synthetic Oil | Front Drive Axle, Front Drive Axle Wheel Bearings, Non-Drive Axle Wheel Bearings, Planetary Axle, Rear Drive Axle, Trailer Axle Wheel Bearings | | GL-5 SAE 75W/140 | -40 | None | -40 | None |
| 0-76N | Full Synthetic Oil | Front Drive Axle, Front Drive Axle Wheel Bearings, Non-Drive Axle Wheel Bearings, Planetary Axle, Rear Drive Axle, Trailer Axle Wheel Bearings | | GL-5 SAE 75W/90 | -40 | None | -40 | None |
| 0-81 | Full Synthetic Oil | Transmission | — | SAE 50 | -40 | None | -40 | None |

14 Specifications

Table DF: Oil Lubricants

| Meritor Specification | Oil | Typical Application | Military/SAE Specifications | Oil Description | Outside Temperature | | | |
|--------------------------|-----------------------------|---------------------|--------------------------------|--|---------------------|------|------|------|
| | | | | | °F | | °C | |
| | | | | | Min. | Max. | Min. | Max. |
| — | Heavy Duty Engine Oil | Transmission | MIL-L-2104 -E or -F* | A.P.I. -CD, -CE, -SG, -SH or -SJ; SAE 50 | -10 | None | -12 | None |
| — | Heavy Duty Engine Oil | Transmission | | A.P.I. -CD, -CE, -SG, -SH or -SJ; SAE 40 | -10 | None | -12 | None |
| — | Heavy Duty Engine Oil | Transmission | | A.P.I. -CD, -CE, -SG, -SH or -SJ; SAE 30 | -15 | 10 | -26 | -12 |
| — | Petroleum Gear | Transmission | | A.P.I.-GL-1; SAE 90 | -10 | None | -12 | None |
| — | Petroleum Gear | Transmission | | A.P.I.-GL-1; SAE 80 | -15 | None | -26 | None |

* Current designations are acceptable.

Meritor Heavy Vehicle Systems, LLC

2135 West Maple Road

Troy, MI 48084 USA

866-OnTrac1 (668-7221)

arvinmeritor.com

Copyright 2010
ArvinMeritor, Inc.

Printed in USA

Revised 07-10
Maintenance Manual 1 (16579)

ArvinMeritorTM