

MERITOR®

Installation and Maintenance Manual 14P

Meritor Tire Inflation Systems (MTIS) by P.S.I.™

Standard MTIS

MTIS with the ThermALERT™ System

Revised 06-06

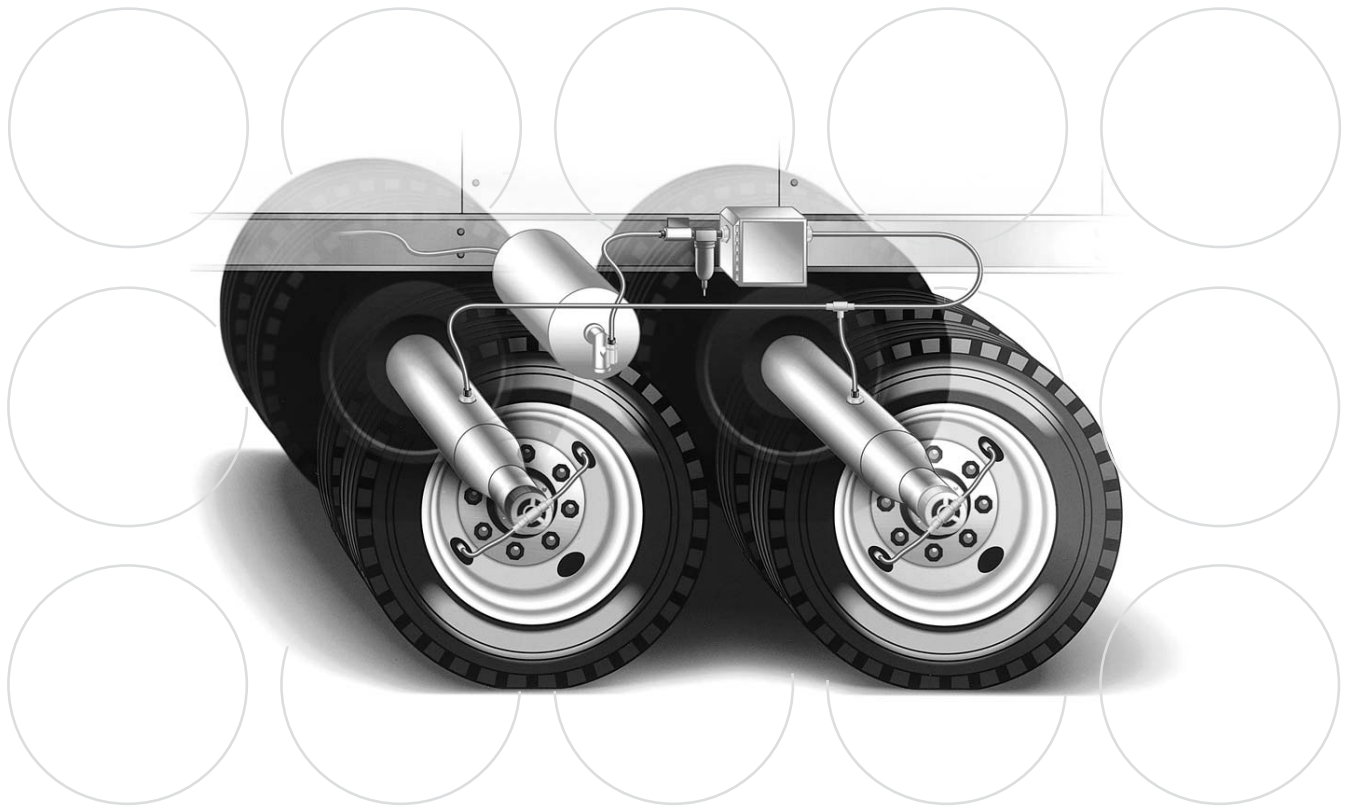

Service Notes

About This Manual

This manual provides installation and maintenance procedures for the Meritor Tire Inflation Systems by P.S.I.™. Use the procedures in this manual to install the standard tire inflation system and the tire inflation system with ThermALERT™ on either new trailer axles at original equipment manufacturers or in-service trailer axles at fleets.

Before You Begin

1. Read and understand all instructions and procedures before you begin to service components.
2. Read and observe all Warning and Caution hazard alert messages in this publication. They provide information that can help prevent serious personal injury, damage to components, or both.
3. Follow your company's maintenance and service, installation, and diagnostics guidelines.
4. Use special tools when required to help avoid serious personal injury and damage to components.

Hazard Alert Messages and Torque Symbols

WARNING

A Warning alerts you to an instruction or procedure that you must follow exactly to avoid serious personal injury and damage to components.

CAUTION

A Caution alerts you to an instruction or procedure that you must follow exactly to avoid damage to components.

 This symbol alerts you to tighten fasteners to a specified torque value.

How to Obtain Additional Maintenance and Service Information

On the Web

Visit Literature on Demand at meritorhvs.com to access product, service, aftermarket, and warranty literature for ArvinMeritor's truck, trailer and specialty vehicle components.

ArvinMeritor's Customer Service Center

Call ArvinMeritor's Customer Service Center at 800-535-5560.

Technical Electronic Library DVD

The DriveTrain Plus™ by ArvinMeritor Technical Electronic Library DVD contains product and service information for most Meritor and Meritor WABCO products. Specify TP-9853.

How to Obtain Tools and Supplies Specified in This Manual

Call ArvinMeritor's Commercial Vehicle Aftermarket at 888-725-9355 to obtain Meritor tools and supplies.

For Grainger tools, visit their website at www.grainger.com to locate a branch near you.

Information contained in this publication was in effect at the time the publication was approved for printing and is subject to change without notice or liability. Meritor Heavy Vehicle Systems, LLC, reserves the right to revise the information presented or to discontinue the production of parts described at any time.

pg. 1	Section 1: Introduction	pg. 36	Section 6: Maintenance
2	Overview		Inspection
	The Standard Meritor Tire Inflation Systems (MTIS) by P.S.I.™		Tires
	The MTIS with the ThermALERT™ System		Component Removal and Installation
	If the MTIS Indicator Light Comes ON When the Air System is Charging		Turn the System OFF
	If the MTIS Indicator Light Comes ON During Operation	37	Remove and Replace the Tires
	Indicator Light	38	Hose Valve Cores
3	Wheel-End Assembly		Remove the Through-Tee Before Installing a Hubcap
	Controls	39	Section 7: Troubleshooting
4	Installation and Maintenance Information		Diagnostics
6	Section 2: Assembly and Installation	41	Section 8: Special Tools
	Installation on Non-Prepped Axles		Tire Inflation System
	Sequence for Installing a Standard MTIS System and an MTIS System with a ThermALERT™ System		
	Axle Air Fitting		
7	Prepare a Hollow Spindle Axle to Install the Standard MTIS and MTIS with the ThermALERT™ System		
12	Prepare a Solid Spindle Axle to Install Standard MTIS Without the ThermALERT™ System		
16	Stator		
	Wheel-End Components		
18	Air Components		
21	Electrical Components		
23	Wheel-End Oil		
	Standard MTIS and ThermALERT™ System Decals		
25	Section 3: Check System Operation		
	Check System Operation		
27	Check the Control Box Pressure		
29	Check the Hose Connections for Leaks		
30	Check the Wheel End for Air Leaks		
32	Section 4: Pre-Service Check		
	Pre-Service Check		
34	Section 5: Inspection and Maintenance		
	Tire Inflation System Inspection Interval Guidelines		
35	Inspection		
	Indicator Light		

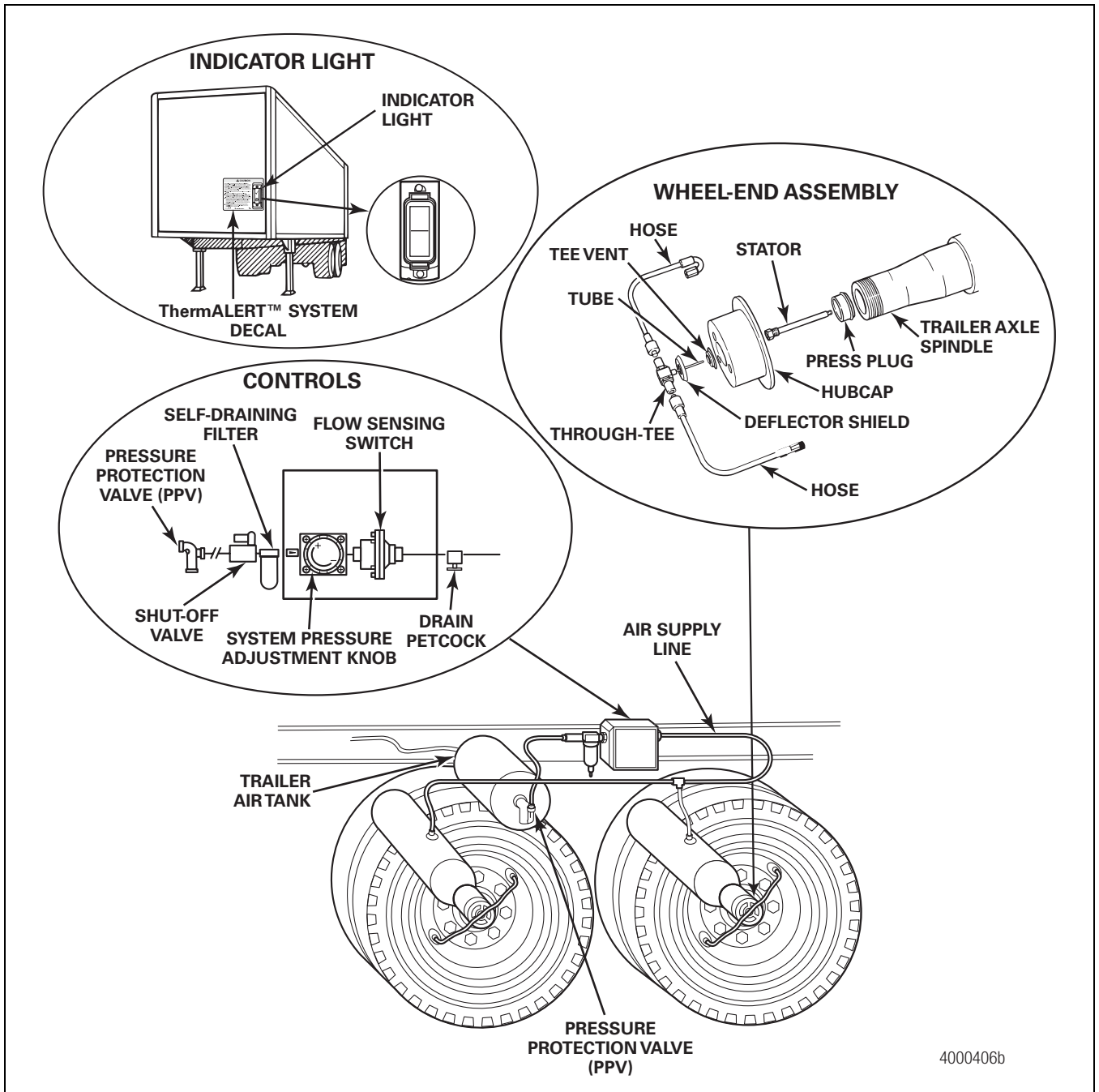

Figure 1.1

1 Introduction

Overview

The Standard Meritor Tire Inflation Systems (MTIS) by P.S.I.™

The Meritor Tire Inflation Systems (MTIS) by P.S.I.™ use compressed air from the trailer to inflate any tire that falls below the system air pressure setting during operation.

Air from the existing trailer air supply is routed to a control box, then into each axle. Refer to Figure 1.1. The axles act as conduits to distribute air through rotary union assemblies at the spindle ends, which then distribute air to each tire as needed. If a tire is leaking, check valves in the tire delivery lines prevent loss of pressure in the remaining tires.

The MTIS indicator light on the front of the trailer will come ON to alert you if there is an excessive amount of air flow through the system, which can be caused by a leaking tire or a loose connection, or both. If the indicator light comes ON during operation, immediately find a safe place to bring the tractor and trailer to a complete stop. You must repair components that caused the air leak before returning the vehicle to service.

Standard MTIS does not eliminate the need to perform wheel-end maintenance at regularly-scheduled intervals.

The MTIS with the ThermALERT™ System

The MTIS with the ThermALERT™ system detects when air is escaping from the axle's thermal plug and out through the hubcap tee vent, which occurs if a wheel end is operating at an abnormally high temperature. The MTIS indicator light will come ON to alert you to immediately find a safe place to bring the tractor and trailer to a complete stop.

Air escaping from the tee vent produces an audible noise, which helps you to identify the wheel end that is overheated. Do not operate the trailer until the components are replaced.

The MTIS ThermALERT™ system does not eliminate the need to perform wheel-end maintenance at regularly-scheduled intervals.

If the MTIS Indicator Light Comes ON When the Air System is Charging

When you start a vehicle, the MTIS indicator light initially may come ON while the air system is charging. However, if the indicator light stays ON for more than 10 minutes, a tire may be damaged and losing air pressure. Inspect the tires for damage and air leaks. Repair damaged or leaking tires before returning the vehicle to service.

If the MTIS Indicator Light Comes ON During Operation

WARNING

If the ThermALERT™ system activates during vehicle operation, you must repair or replace components that caused the wheel end to overheat before returning the vehicle to service. You also must install a new thermal screw, which is not reusable. Otherwise, the indicator light will continue to remain ON during vehicle operation, even though the wheel end has been repaired. If you ignore the indicator light, and another wheel end overheats during operation, serious personal injury and damage to components can result.

The MTIS with the ThermALERT™ system detects when air is escaping from the axle's thermal plug and out through the hubcap tee vent, which occurs if a wheel end is operating at an abnormally high temperature. The MTIS indicator light will come ON to alert you that air flow through the system is excessive.

1. Immediately find a safe place to bring the tractor and trailer to a complete stop.
2. Inspect the trailer hubs for air leaks.
3. Listen for the ThermALERT™ system's audible sound at the wheel end. If you hear the sound, the wheel end is overheated. Do not operate the trailer until the wheel-end components are repaired. If a wheel end overheats during operation, it can separate from the vehicle. Serious personal injury and damage to components can result.
4. If you do not hear the ThermALERT™ system's audible sound at the wheel end, inspect the tires for damage. Repair damaged or leaking tires before returning the vehicle to service.

Indicator Light

An indicator light mounted on the front of the trailer comes ON when the system delivers an excessive amount of air due to a leaking tire, tire inflation system component, or if equipped with a ThermALERT™ system, a wheel end operating at an abnormally high temperature.

An MTIS system with a ThermALERT™ system will also have a ThermALERT™ system decal installed at the indicator light on the trailer.

Wheel-End Assembly

Stator and Through-Tee

The stator is located inside the axle spindle and the through-tee is attached to the hubcap. Pressurized air passes from the stationary axle interior to the rotating hub through a tube extending from the through-tee into the stator. A dynamic seal, located in the through-tee, allows rotation without loss of air pressure.

Hoses

A hose is a flexible valve stem extension which mechanically opens the tire valve stem and allows air to pass into a tire. A check valve located at the knurled end of a hose allows air to flow in only one direction-towards the tire. This protects each tire from loss of air pressure if the tire inflation system, or any tire, loses air pressure during operation.

There are two sizes of tire inflation system hoses: short, for 17- and 19-inch wheels; and long, for 22.5- and 24.5-inch wheels.

Tee Vent

The tee vent ensures that there is no pressure buildup in the wheel end. If the MTIS is equipped with the ThermALERT™ system, air escaping past this vent will produce an audible sound which indicates that the wheel end has been operating at an abnormally high temperature.

Deflector Shield

The deflector shield helps prevent any contaminants such as dirt and water from entering the wheel end.

Hubcap

The hubcap features six vent holes designed to prevent pressure buildup in the wheel end. Working with the tee vent and the deflector shield, the wheel-end interior is allowed to vent while contaminants are prevented from entering the wheel end. Hubcaps for oil-lubricated wheel ends typically have a side fill plug for adding lubricant.

Press Plug

The press plug is used in axles with hollow spindles to seal off the pressurized axle interior from the wheel end and provide a means of holding and securing the stator.

Refer to Figure 1.2 for a comparison of the standard MTIS axle plug and the ThermALERT™ system axle plug.

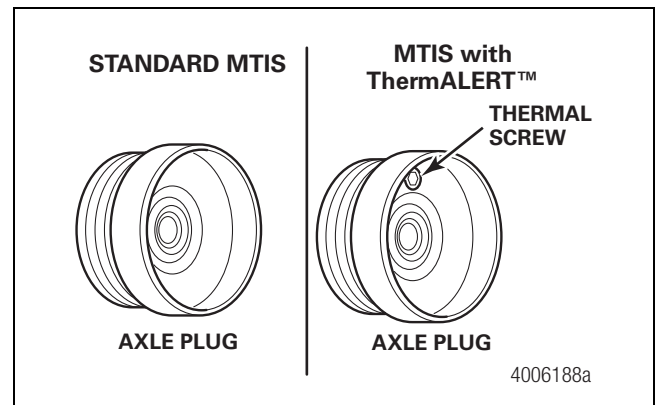

Figure 1.2

Controls

Self-Draining Filter

The self-draining filter automatically removes liquids and contaminants from the air system.

Flow Sensing Switch

⚠ WARNING

The standard MTIS can have a control box with either a black flow sensing switch or a grey flow sensing switch. Both control boxes mount to the trailer in the same way. However, MTIS equipped with a ThermALERT™ system must have a control box with a grey flow sensing switch, which is more sensitive to air flow than the black switch.

If a ThermALERT™ system has a control box with a black flow sensing switch, replace it with a control box that has a grey switch. Otherwise, the indicator light may not come ON if a wheel end overheats. Serious personal injury and damage to components can result.

The flow sensing switch illuminates the indicator light when the system delivers an excessive amount of air to either a leaking tire, a leaking tire inflation system component; or if equipped with the ThermALERT™ system, a wheel end operating at an abnormally high temperature.

The control box for the standard MTIS can include a flow sensing switch that is either black or grey. The control box for the MTIS with the ThermALERT™ system must include a grey flow sensing switch. Both control boxes mount to the trailer in the same way.

1 Introduction

Drain Petcock

The drain petcock is used to manually exhaust pressure from the tire inflation system. This enables you to perform maintenance on either the trailer axle components or the tire inflation system.

System Pressure Adjustment Knob

The system pressure adjustment knob is used to adjust system air pressure. The system air pressure should be adjusted in accordance with the tire pressure required.

Shut-Off Valve

The shut-off valve stops air delivery to the system.

Pressure Protection Valve (PPV)

The pressure protection valve (PPV) ensures that air is available for other trailer functions. Air will not be delivered to the tire inflation system until the trailer air system is charged to at least 80 psi (551 kPa). The PPV also maintains air tank pressure if a tire or a tire inflation system component is damaged.

Installation and Maintenance Information

Use the procedures in this manual to install the tire inflation system on either new trailer axles at original equipment manufacturers or in-service axles at fleets.

The tire inflation system can be installed onto trailer axles manufactured either by Meritor, Holland, Hendrickson, Ingersoll, Dana, Eaton or Sudisa. When installing the system, follow the maintenance instructions provided by these various manufacturers. For trailer axles manufactured by Meritor, refer to Maintenance Manual 14, Trailer Axles. To obtain this publication, refer to the Service Notes page on the front inside cover of this manual.

Trailer axles may be manufactured with either hollow or solid spindles. Additionally, Meritor provides axle models prepped for installation of the standard tire inflation system and the ThermalERT™ system. The system installation sequence is different depending on the axle type. Refer to the information in the following sections.

Hollow Spindle Axle

Most hollow spindle trailer axles have a spindle that's integrally formed out of axle tube material. A welsh plug is pressed into a machined recess in the end of the spindle. If you're unsure of the axle type, contact the axle manufacturer. Figure 1.3.

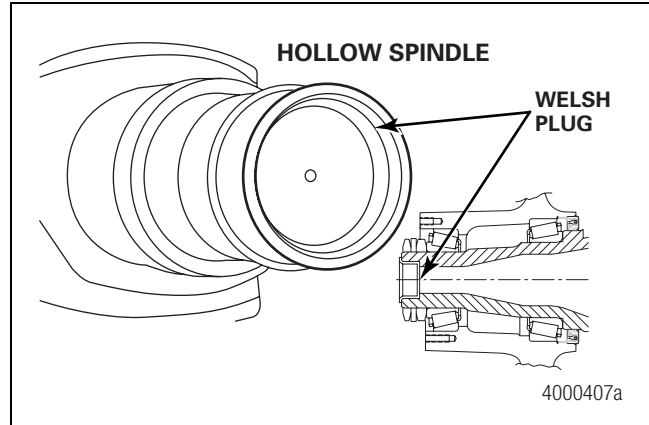

Figure 1.3

Solid Spindle Axle

Most solid spindle trailer axles have a forged spindle welded to the axle tube. If you're unsure of the axle type, contact the axle manufacturer. Figure 1.4.

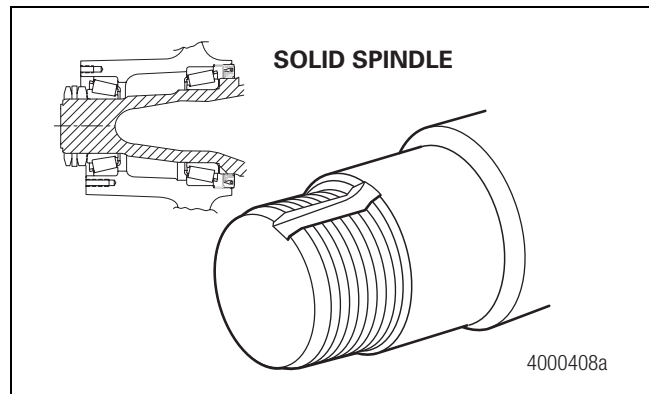

Figure 1.4

Prepped Axle

A trailer axle that has been prepped by Meritor has the following provisions. Other axle manufacturers' prep may vary.

- Debris has been cleaned from the axle interior.
- The standard tire inflation system press plug and stator are installed into the axle spindle. Figure 1.5.
- If equipped with the ThermALERT™ system, the axle press plug with the thermal screw and stator are installed into the axle spindle. The thermal screw must be installed at the 12 o'clock position when the axle is sitting in the running position. Figure 1.6.
- The axle top-center hole is tapped to accept the tire inflation system axle air fitting, and a plug is installed into this hole. Some axle manufacturers may select an alternate location for this hole. Figure 1.7.

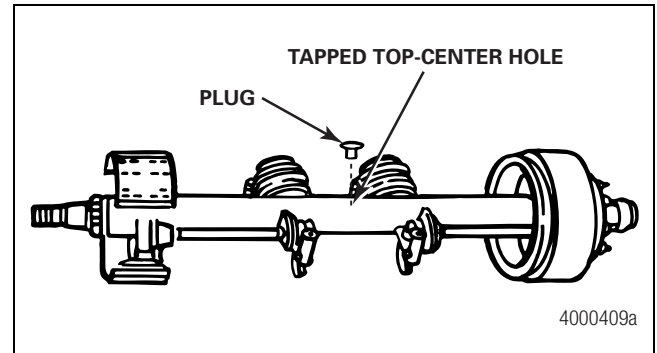

Figure 1.7

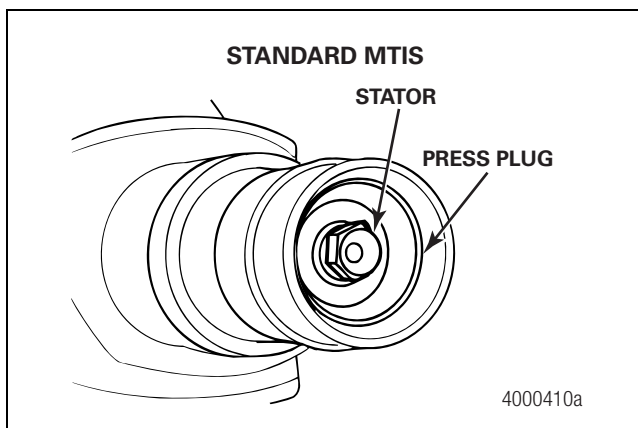

Figure 1.5

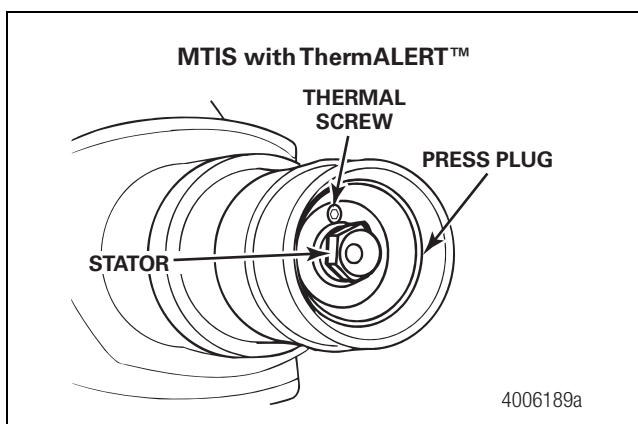

Figure 1.6

2 Assembly and Installation

Hazard Alert Messages

Read and observe all Warning and Caution hazard alert messages in this publication. They provide information that can help prevent serious personal injury, damage to components, or both.

⚠ WARNING

To prevent serious eye injury, always wear safe eye protection when you perform vehicle maintenance or service.

Park the vehicle on a level surface. Block the wheels to prevent the vehicle from moving. Support the vehicle with safety stands. Do not work under a vehicle supported only by jacks. Jacks can slip and fall over. Serious personal injury and damage to components can result.

Installation on Non-Prepped Axles

Sequence for Installing a Standard MTIS System and an MTIS System with a ThermALERT™ System

1. Install the axle air fitting.
2. Prepare the axle.
3. Install the stator.
4. Install the wheel-end components.
5. Follow the remaining sections in the manual for the air and electrical components.

Axle Air Fitting

1. Wear safe eye protection.
2. Park the vehicle on a level surface. Block the wheels to prevent the vehicle from moving.
3. On Meritor axles, locate the top-center of the axle, which is the preferred location for the axle air fitting. For other axle manufacturers, this location may vary. If the axle manufacturer has installed a top-center hole in the axle, use this hole as a pilot when you drill for the air fitting. Figure 2.1.

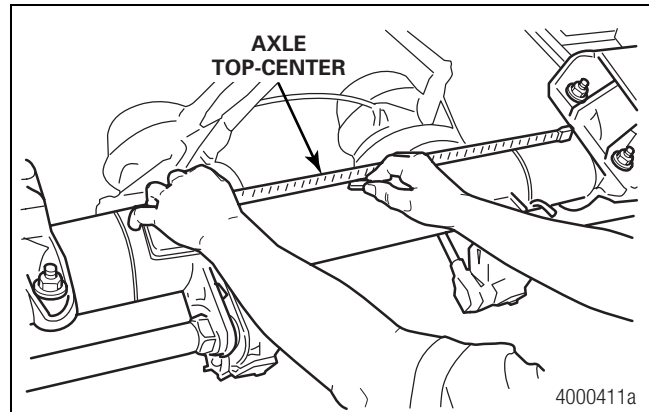

Figure 2.1

4. Use drilling lubricant and a variable speed electrical drill to drill an 11/32-inch diameter hole STRAIGHT into the top-center of the axle. Figure 2.2.

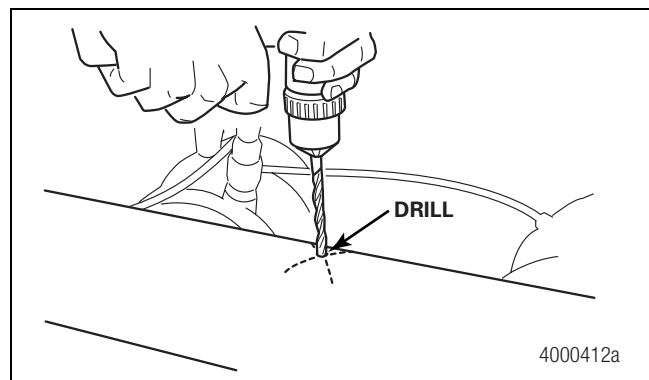

Figure 2.2

5. Use tapping lubricant and a 1/8-inch NPT tap to tap the drilled hole STRAIGHT into the axle. Do not run the tap completely through the hole. Leave some thread taper in the tapped hole. Figure 2.3.

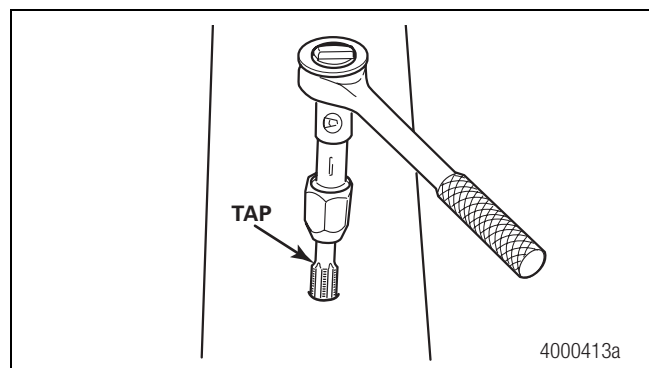

Figure 2.3

- Hand-tighten the axle air fitting into the tapped hole. Then use a 1/2-inch wrench to tighten the fitting 2-1/2 additional turns to obtain an air tight seal. Continue to tighten until the fitting faces TOWARD the side of the trailer where you'll install the system control box. Figure 2.4. It is not necessary to apply a sealer when the axle air fitting is first installed if current production fittings have sealant pre-applied to the threads. If the part is removed, however, apply a sealer such as Teflon® tape to the threads prior to reinstalling. Figure 2.5.

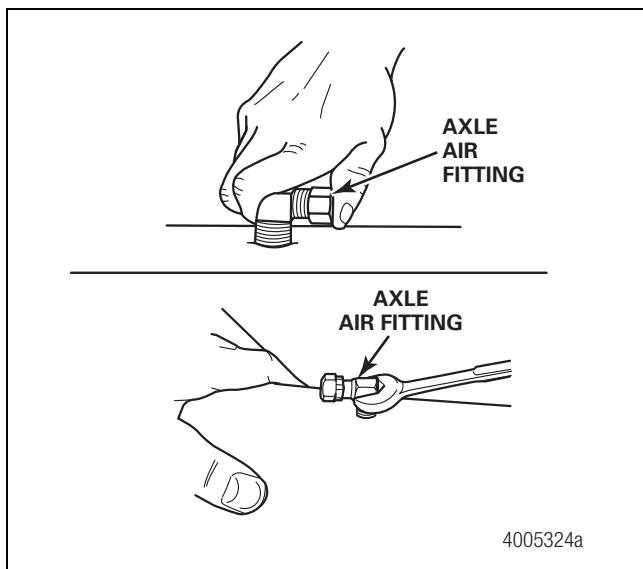

Figure 2.4

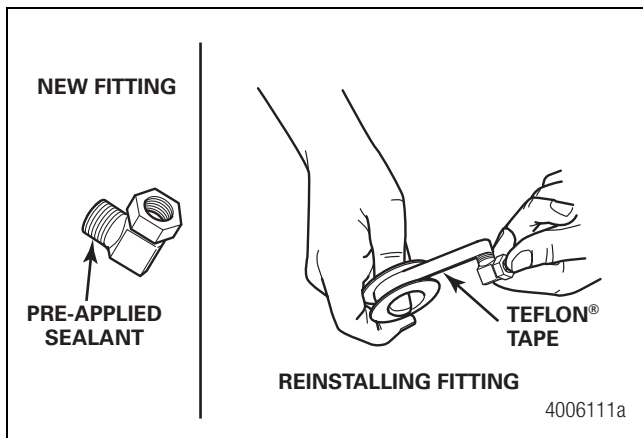

Figure 2.5

Prepare a Hollow Spindle Axle to Install the Standard MTIS and MTIS with the ThermALERT™ System

⚠ CAUTION

Cover the wheel ends at both ends of the axle during system installation to prevent contaminants from entering the wheel end. Damage to the bearings and seals can result.

- Wear safe eye protection.
- Park the vehicle on a level surface. Block the wheels to prevent the vehicle from moving.
- Place a container under the hubcap to receive the draining oil. Then, remove the hubcap and hubcap gasket from both ends of the axle. Figure 2.6. Do not reuse either the hubcap gasket or the oil.

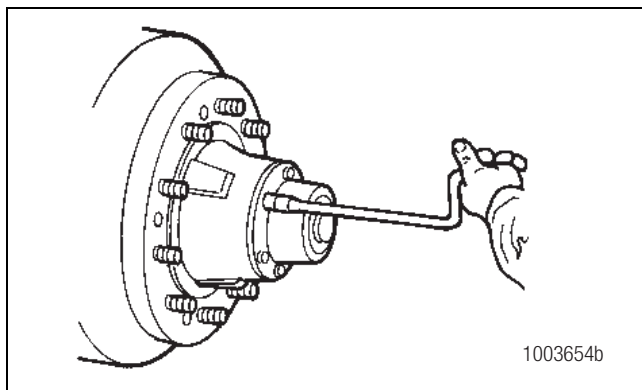

Figure 2.6

- Cover the wheel ends at both ends of the axle with a clean towel. Figure 2.7.

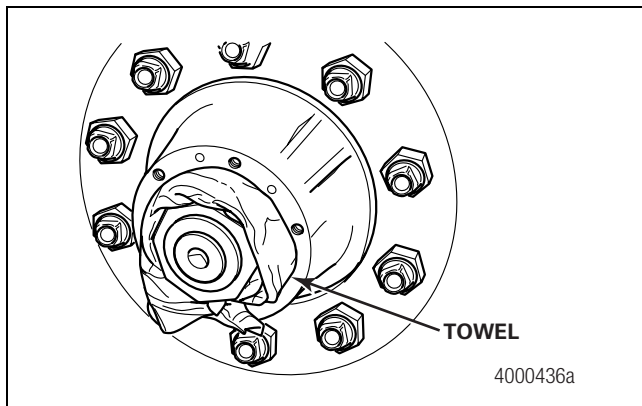

Figure 2.7

2 Assembly and Installation

- Use a slide hammer fitted with the welsh plug removal spear to remove the spindle welsh plugs from both ends of the axle. Use care not to score the inside diameter of the spindle bore. Figure 2.8. A slide hammer and welsh plug removal spear are available from Meritor to help remove these plugs. Refer to Section 8 for part numbers of special tools and supplies.

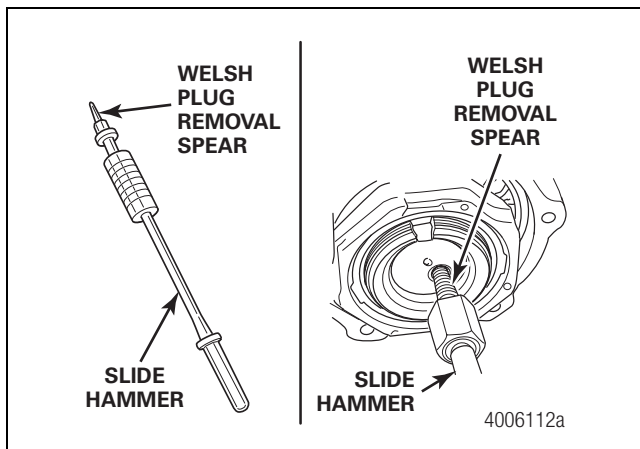

Figure 2.8

⚠ CAUTION

Use a bore polisher to remove all old adhesive from the spindle bore before you apply retaining compound to install the press plug. Retaining compound must contact a bare metal surface or it will not harden. Damage to components can result.

- Choose the correct sized bore polisher by matching the axle manufacturer and model to the bore polishing tools listed in Section 8. Figure 2.9.

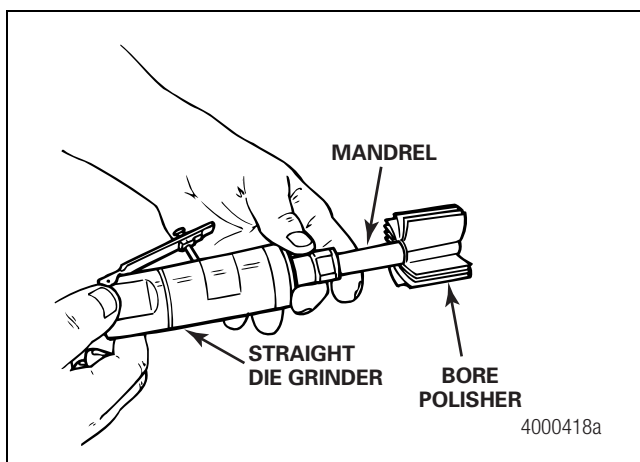

Figure 2.9

- Polish the spindle bore to remove all adhesive residue left from the old spindle plug and any metal burrs or sharp edges from the spindle bore surface. Figure 2.10.

- If the axle spindle is equipped with cotter pin holes:** Use a round abrasive tool to remove all metal burrs and sharp edges from the spindle bore side of the cotter pin holes. Figure 2.11.

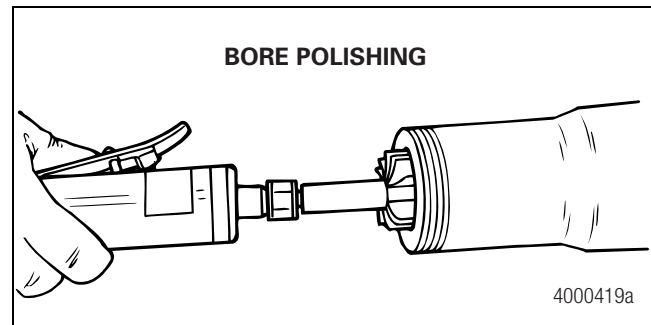

Figure 2.10

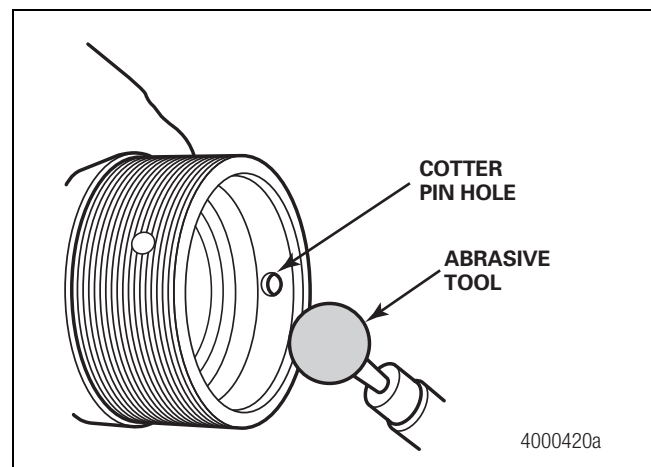

Figure 2.11

⚠ CAUTION

Use a cleaning wand and high-volume air to clean debris from the axle interior before you install the tire inflation system press plugs. Check that the axle is clear of debris, including loose rust, scale, liquid and machining residue. A contaminated axle can damage the tire inflation system and void the warranty.

- Connect a cleaning wand to a high-volume air supply. Refer to Section 8 for information on building a cleaning wand. Figure 2.12. Slowly push the wand through the axle until it exits the opposite end. During this operation, a steady stream of air will be blowing from the axle spindle. Figure 2.13.

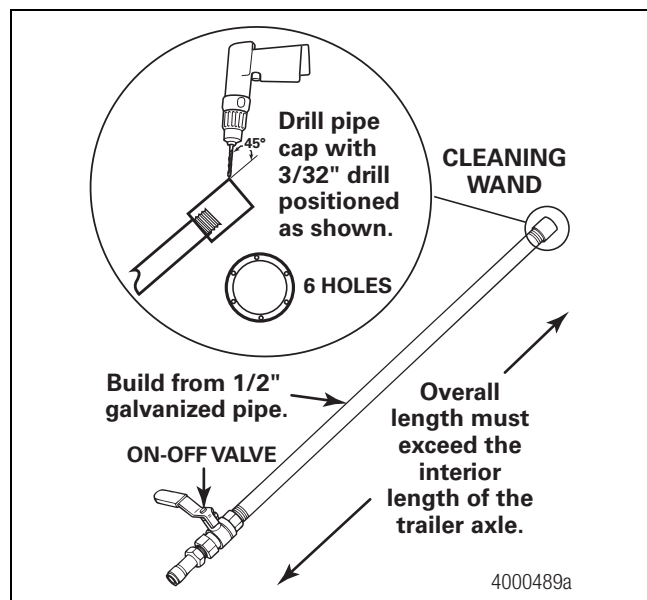

Figure 2.12

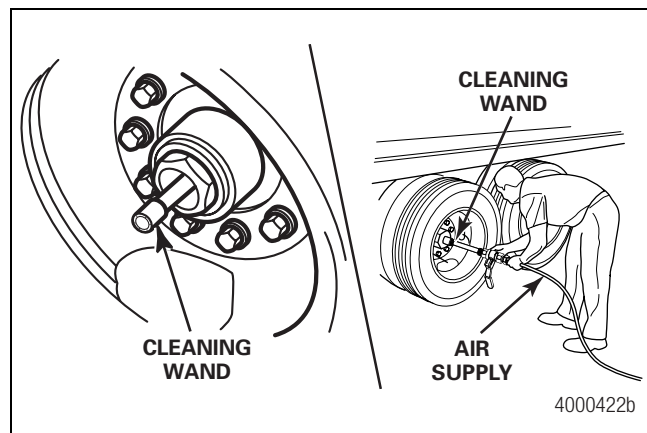

Figure 2.13

- Check the inside of the axle tube with a flashlight by shining the light into one end of the spindle and looking through the opposite end. Confirm that all debris, including loose rust, scale, liquid and machining residue has been removed. Figure 2.14.

- If necessary:** Repeat the cleaning procedure until the axle is clear of debris. For debris that's difficult to remove, it may be helpful to push the cleaning wand through the axle from the opposite end.

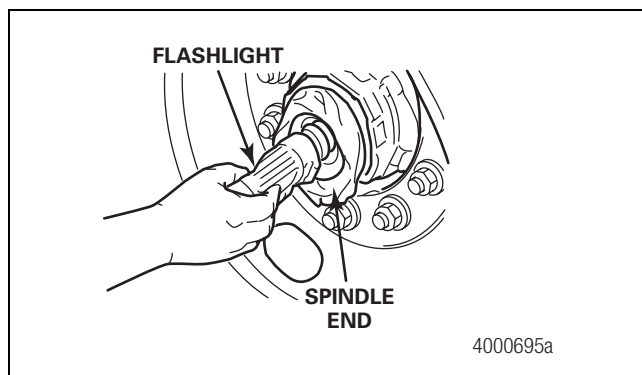

Figure 2.14

- Choose the correct press plug drive adaptor by matching the axle manufacturer and model to the press plug drive adaptors. Refer to Section 8. Figure 2.15. Current production press plug drive adaptors are identified with a number stamped on the part. Some early adaptors were not marked.

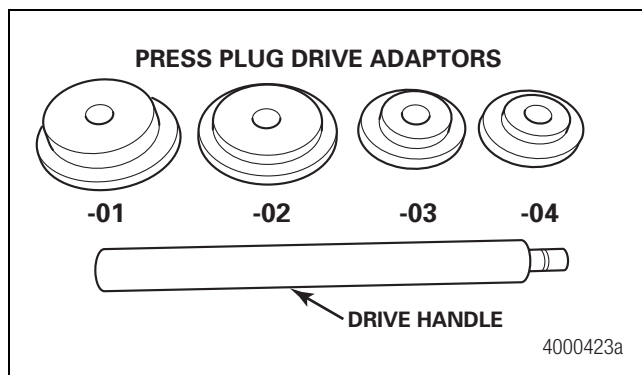

Figure 2.15

2 Assembly and Installation

11. Install the press plug drive adaptor onto the drive handle.
Figure 2.16.

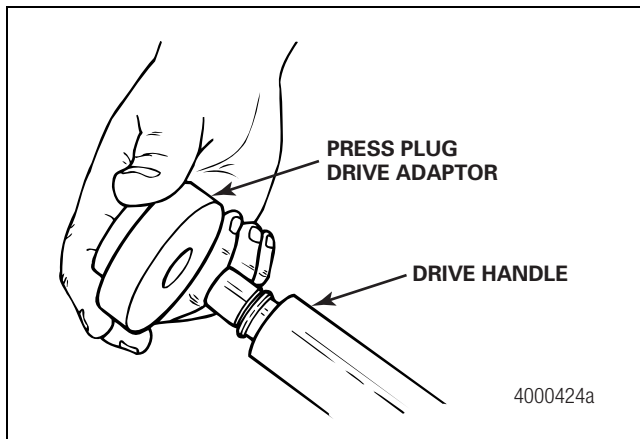

Figure 2.16

12. Clean the exposed O-ring surface and outside diameter surface of one press plug using a towelette provided in the installation kit. Use a new towelette for each wheel end. Protect the cleaned plug from additional contaminants. Figure 2.17.

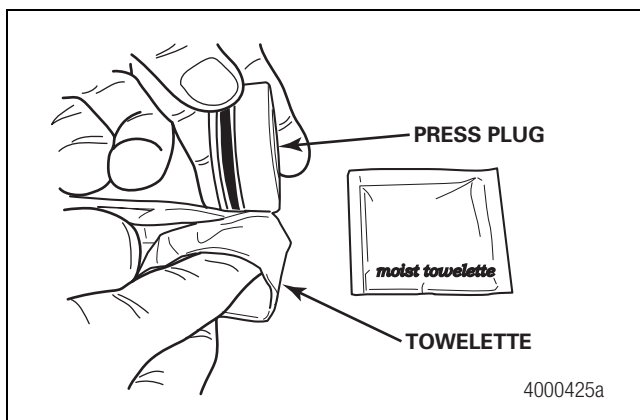

Figure 2.17

13. Use the same towelette to clean one spindle bore of contaminants such as grinding dust, dirt and wheel-end lubricant. Protect the cleaned bore from additional contaminants. Figure 2.18.

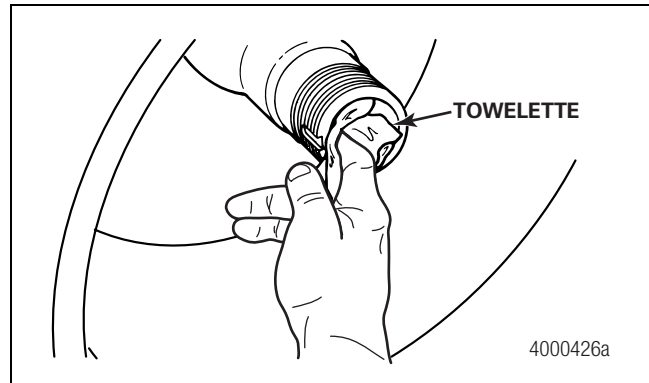

Figure 2.18

⚠ CAUTION

Only use the retaining compound supplied in the installation kit when you install the press plug. Only apply retaining compound to the **OUTSIDE** diameter of the press plug. Do not apply it to the **inside** diameter of the spindle bore, press plug stator threads or axle spindle threads. Damage to components can result.

14. Put on a new pair of latex gloves. Apply the retaining compound included in the installation kit evenly to the **OUTSIDE** diameter of the press plug. The installation kit contains enough retaining compound for four wheel ends. Divide the material equally among the wheel ends. The press plug must be installed within 10 minutes of applying the retaining compound to ensure that the compound hardens correctly. Figure 2.19.

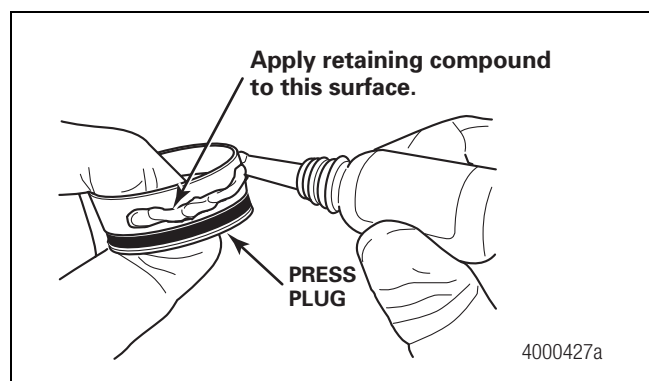

Figure 2.19

15. If you are installing a press plug fitted with a thermal screw for a ThermALERT™ system, install the plug with the thermal screw set at the 12 o'clock ($\pm 15^\circ$) position. Figure 2.20.

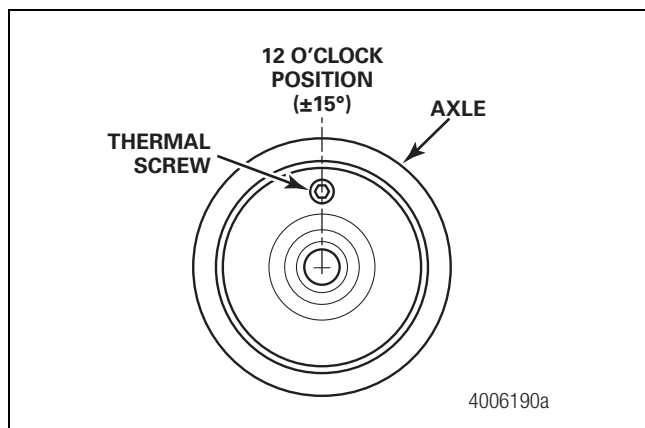

Figure 2.20

16. Insert the press plug into the spindle bore until the plug stops in the bore. Figure 2.21.

- **For Holland Propar Axles Only:** The press plug slots must align with the spindle cotter pin holes. Figure 2.22.

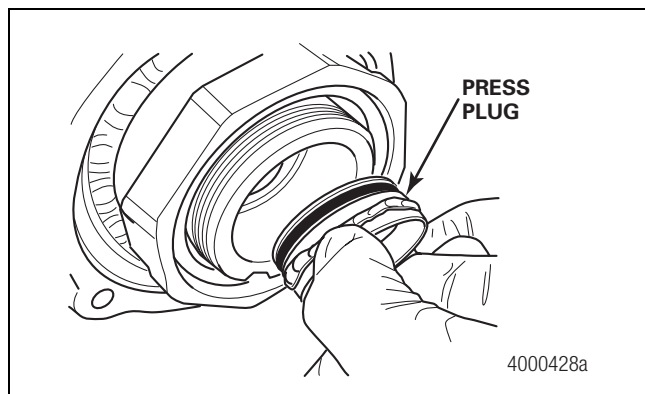

Figure 2.21

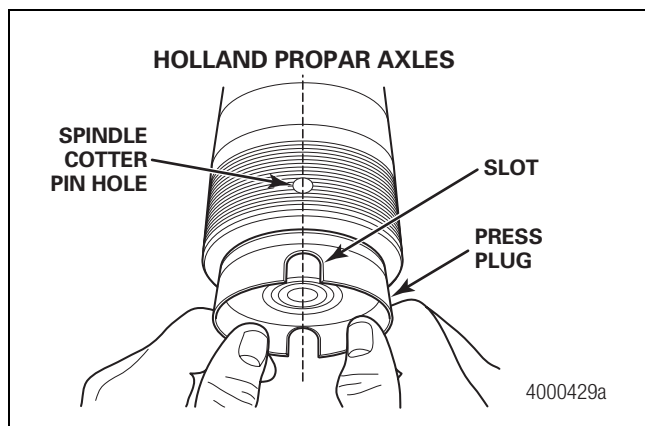

Figure 2.22

17. Check that the press plug protrudes from 1/8-1/4-inch (3.175-6.35 mm) from the end of the spindle. Figure 2.23.

- **If the press plug protrudes outside this acceptable range:** Before proceeding, contact ArvinMeritor's Customer Service Center at 800-535-5560.
- **If the plug is fitted with a thermal screw for a ThermALERT™ system:** Ensure that the thermal screw is located UP at the 12 o'clock ($\pm 15^\circ$) position when the axle is installed under the trailer. Figure 2.20.

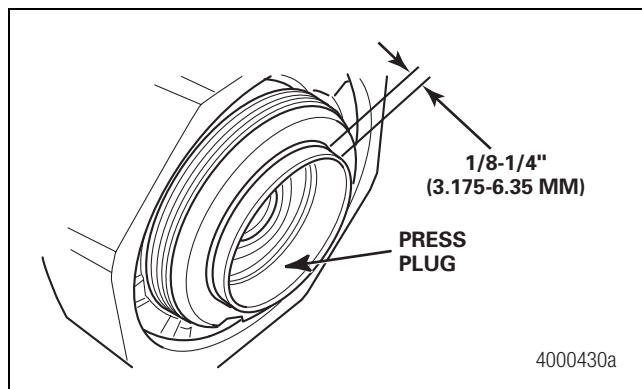

Figure 2.23

18. Insert the press plug drive adaptor into the press plug. Figure 2.24.

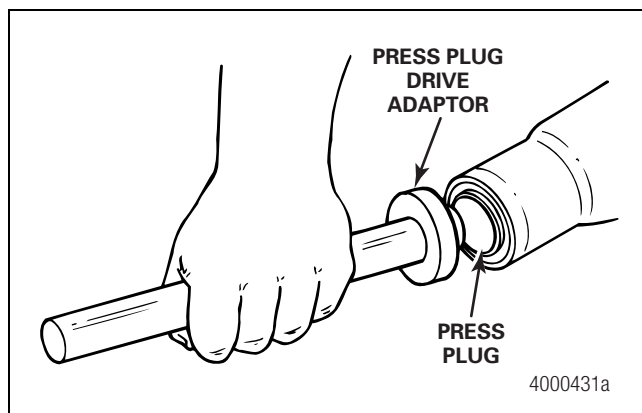

Figure 2.24

2 Assembly and Installation

⚠ WARNING

Use a brass or synthetic mallet for assembly and disassembly procedures. Do not hit steel parts with a steel hammer. Pieces of a part can break off. Serious personal injury and damage to components can result.

⚠ CAUTION

The installed press plug must be seated square to the end of the spindle and inset at or below any chamfer in the axle spindle bore. A press plug that is flush with the end of the spindle is not seated correctly. Damage to components can result.

19. Use a four-pound brass or synthetic mallet to drive the press plug into the spindle bore, until the drive adaptor bottoms out squarely on the end of the spindle. The drive adaptor sets the press plug installation depth. There will be a definite change in the sound and feel of the hammering when the drive adaptor bottoms out. The tire inflation system can be pressurized 30 minutes after installation of the press plug. Figure 2.25.

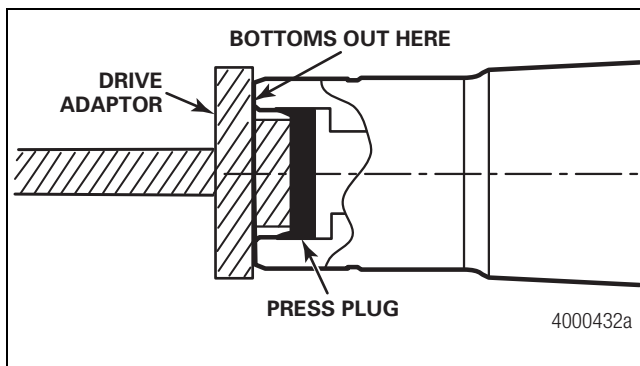

Figure 2.25

20. Wipe off all retaining compound residue from the spindle and press plug drive adaptor. Figure 2.26.

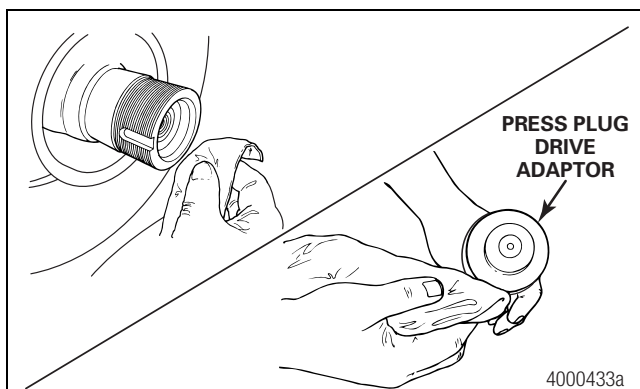

Figure 2.26

Prepare a Solid Spindle Axle to Install Standard MTIS Without the ThermALERT™ System

Important Note: The ThermALERT™ system cannot be installed onto a solid spindle axle.

Only use Meritor's drill jig (part number 81023-00) to drill a hole into a solid spindle axle to install the tire inflation system. Refer to the Service Notes page on the front inside cover of this manual to obtain the drill jig.

1. Wear safe eye protection.

⚠ CAUTION

Use only Meritor's solid spindle drill jig (part number 81023-00) to drill a hole into a solid spindle axle to install the tire inflation system. Meritor's drill jig helps to ensure that the hole will be square to the spindle end. Do not drill a hole into the axle by hand. Do not use a drill jig from another manufacturer, or install the drill jig as an assembly. Damage to components can result.

2. Use a Meritor drill jig. Correctly support the Meritor drill jig with at least two full spindle threads. If necessary, remove the trailer axle outer spindle nut to expose at least two full threads. Figure 2.27.

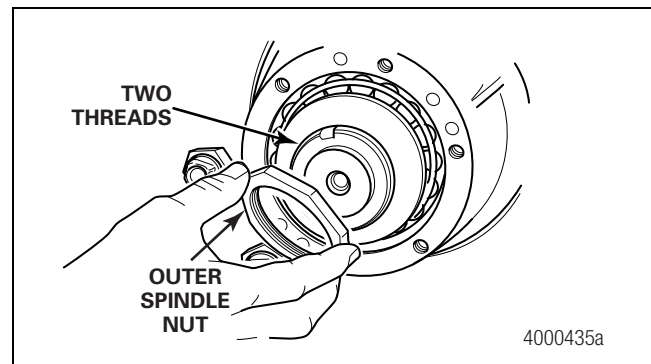

Figure 2.27

⚠ CAUTION

Cover the wheel ends at both ends of the axle during system installation to prevent contaminants from entering the wheel end. Damage to the bearings and seals can result.

3. Cover the wheel ends at both ends of the axle with a clean towel. Figure 2.28.

2 Assembly and Installation

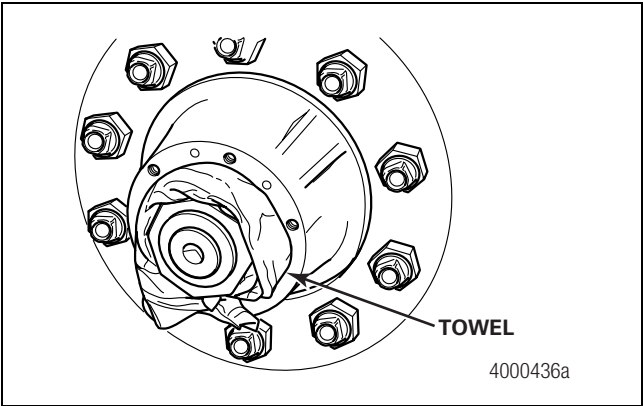

Figure 2.28

4. Clean the drill jig spindle installation nut and the axle spindle nut. This will allow the drill jig to be correctly squared to the axle.
5. Install the 12 x 7/16-inch diameter drill bit into the drill. Figure 2.29.

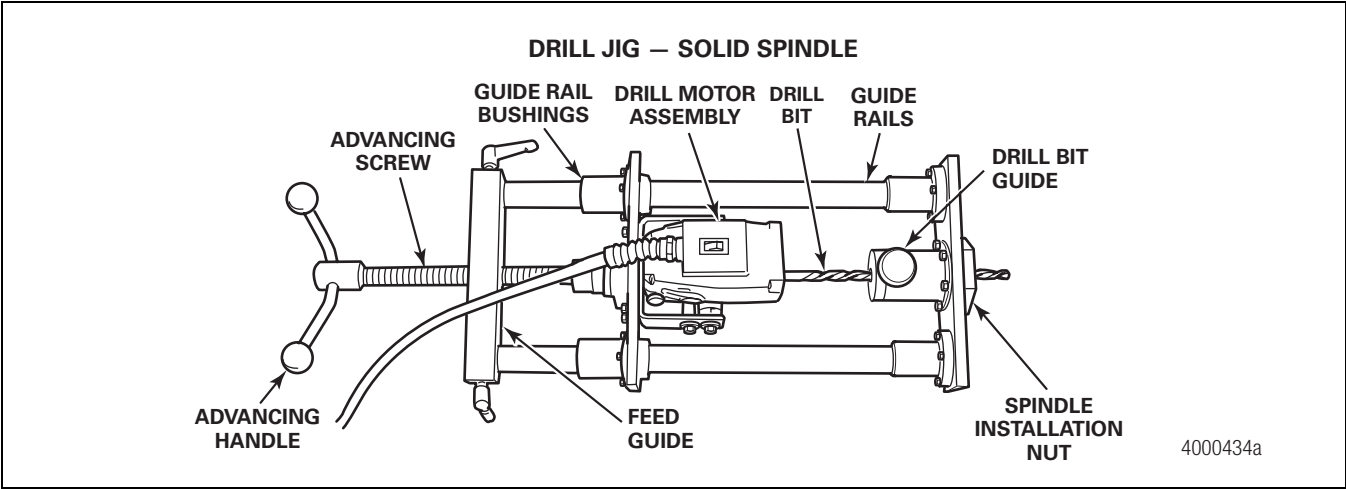

Figure 2.29

2 Assembly and Installation

6. Thread the guide rails onto the axle spindle. Use a bar to tighten the rails. Figure 2.30.

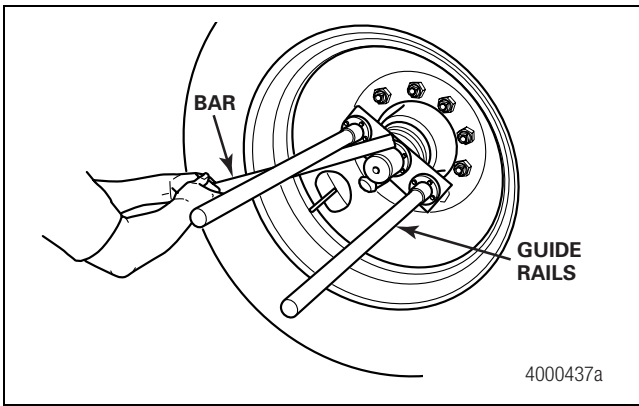

Figure 2.30

8. Tighten the feed guide onto the guide rails. Figure 2.33.

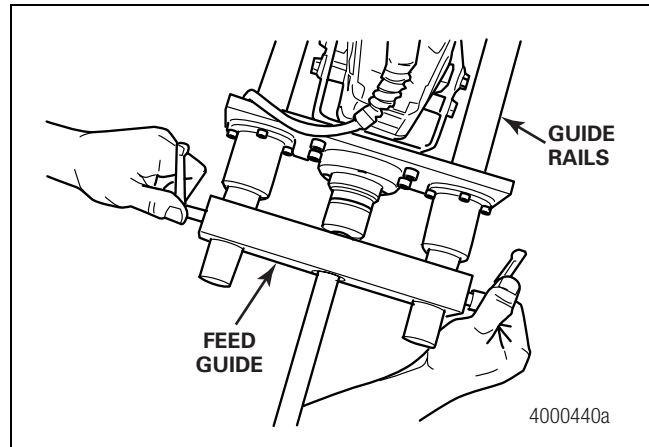

Figure 2.33

7. Slide the drill motor assembly onto the guide rails. Ensure that the drill bit is inserted into the drill bit guide. Figure 2.31 and Figure 2.32.

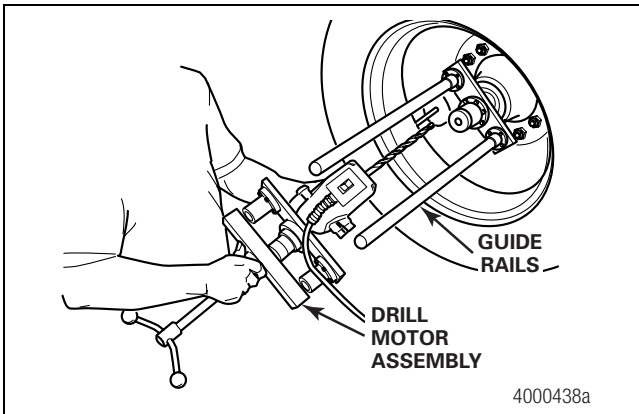

Figure 2.31

9. Turn the advancing handle CLOCKWISE until the drill bit bottoms out on the spindle. Then, back off the handle one full turn. Figure 2.34.

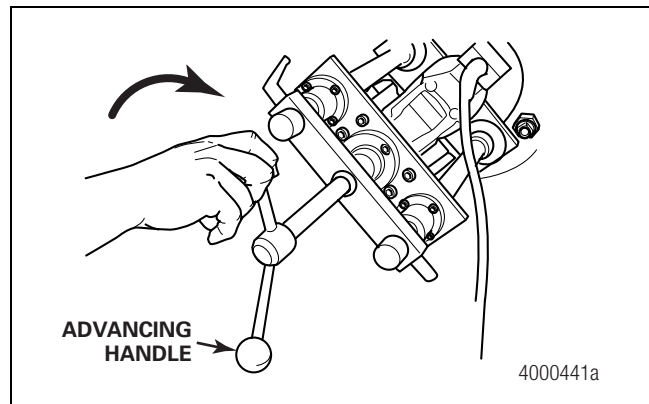

Figure 2.34

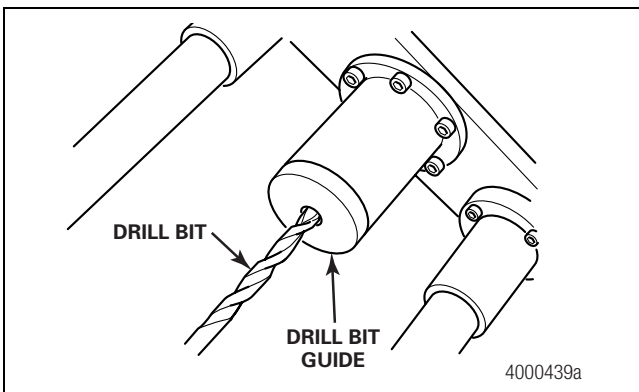

Figure 2.32

2 Assembly and Installation

10. Turn the motor ON and drill into the spindle by slowly turning the advancing handle CLOCKWISE with a smooth, steady feed. Remove the drill bit guide periodically to remove metal shavings. No lubrication is needed during the drilling operation. Check that the guide rails are clean to ensure that the drill will advance smoothly. Figure 2.34 and Figure 2.35.

- **If the drill stalls or lags:** Back off the advancing handle COUNTERCLOCKWISE a few turns while the drill is on, then resume drilling. Figure 2.36.
- **When the drill bottoms out or breaks through the solid spindle:** Turn the advancing handle COUNTERCLOCKWISE a few turns while the drill is on. Release the feed guide and pull the drill out of the hole.
- **If the 12-inch drill bit does not break through:** Install the 18 x 7/16-inch drill bit. Use the same procedure to continue to drill until you break through the solid spindle.

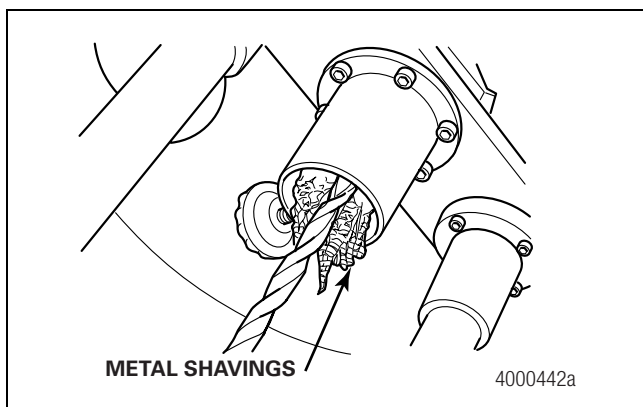

Figure 2.35

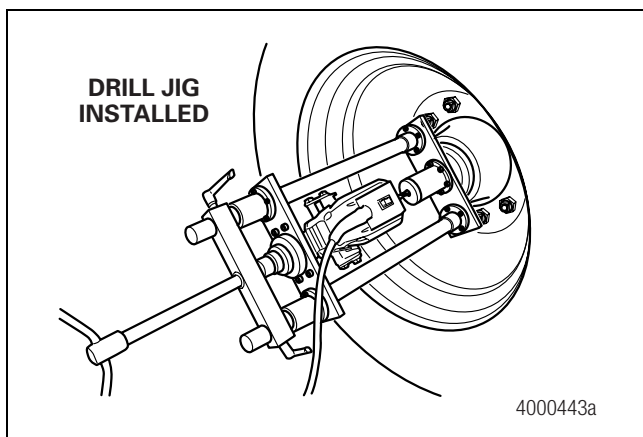

Figure 2.36

11. Remove all drill jig components from the spindle. Clean the axle end. Use shop air to clean the drilled hole. Figure 2.37.

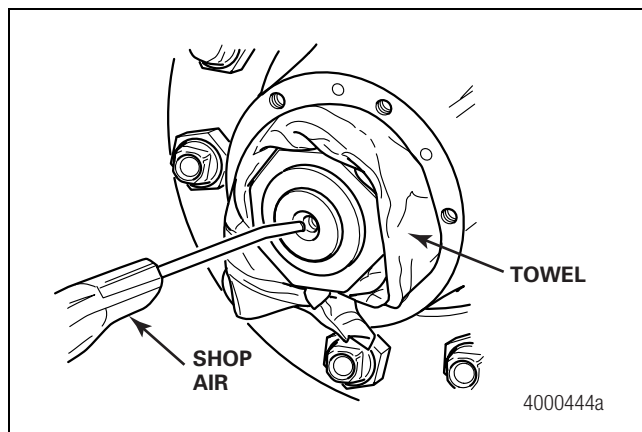

Figure 2.37

⚠ CAUTION

Always use a tap guide to tap the hole in the axle spindle. This will help to ensure that the threads are square to the spindle end and help prevent damage to components.

12. Install the tap guide onto the axle spindle. Tap the axle spindle with a 1/4-inch NPT tap. Use tapping lubricant. Figure 2.38. Refer to Section 8 for the solid spindle tap guide part number.

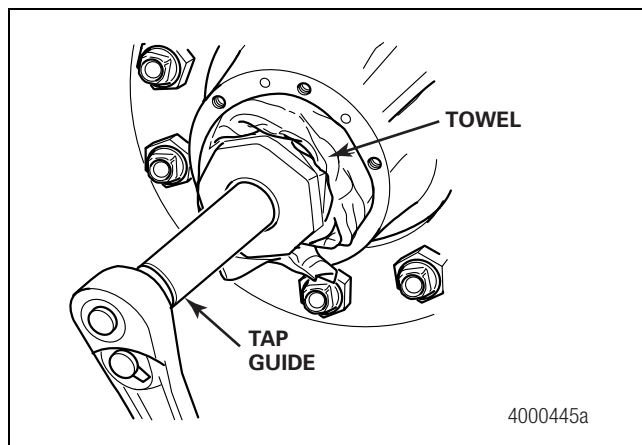

Figure 2.38

2 Assembly and Installation

13. Remove the tap guide. Clean the axle end. Use shop air to clean the tapped hole. Figure 2.37.

- **If the outer spindle nut was removed to install the drill jig:** Reinstall the spindle nut using the axle manufacturer's instructions. Verify that the wheel end play is correct. For Meritor axles, refer to Maintenance Manual 14, Trailer Axles. To obtain this publication, refer to the Service Notes page on the front inside cover of this manual.

Stator

It is not necessary to apply a sealer when the stator is first installed if current production stators have sealant pre-applied to the threads. If the part is removed, however, apply a sealer such as Teflon[®] tape to the threads prior to reinstalling. Figure 2.39.

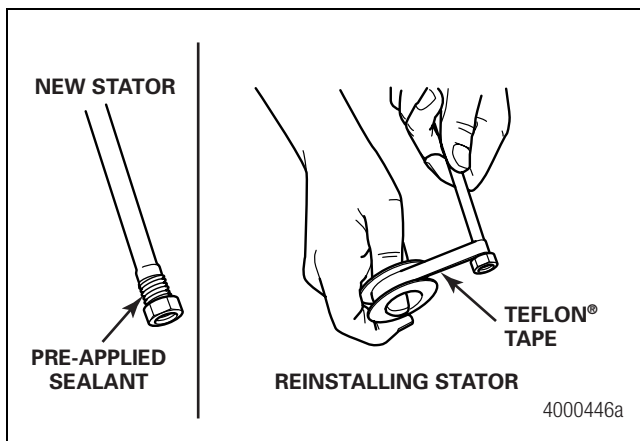

Figure 2.39

1. Hand-tighten the stator into the spindle hole. Figure 2.40.

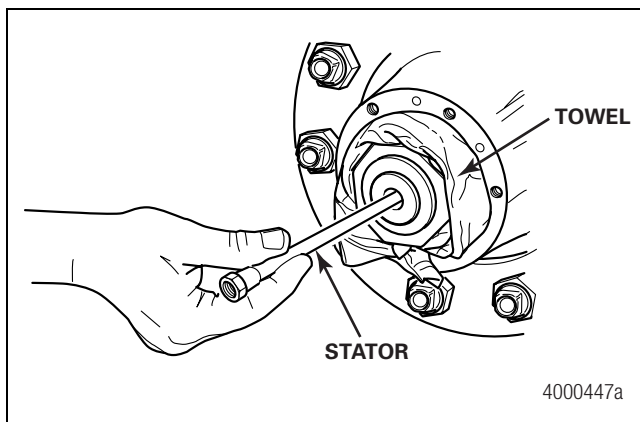



Figure 2.40

2. Use a 5/8-inch socket to tighten the stator approximately 2-1/2 additional turns, or 20-25 lb-ft (27.11-33.89 N•m), to obtain an airtight seal. Figure 2.41. 

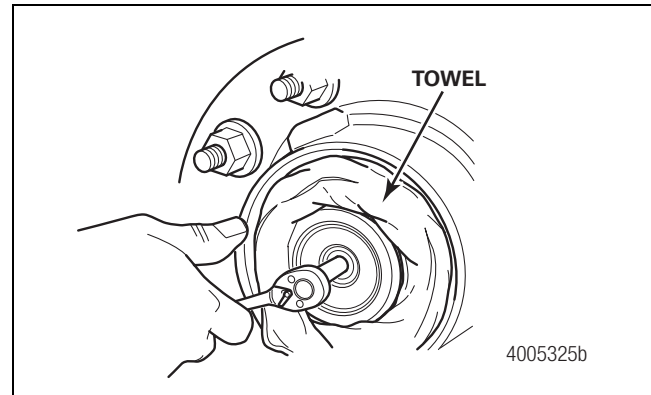

Figure 2.41

Wheel-End Components

Hubcaps are available in bolt-on or screw-on models, and models for grease or oil-lubricated wheel ends. All tire inflation system hubcaps include six vent holes designed to prevent pressure buildup in the wheel end.

Oil hubcaps typically feature a side-mounted oil fill plug and vent hole extensions located in the hubcap interior to keep oil from leaking from the hubcap vent holes. Figure 2.42 and Figure 2.43. Grease hubcaps also have six vent holes with vent extensions, however, they typically don't have a side-mounted fill plug. Figure 2.43.

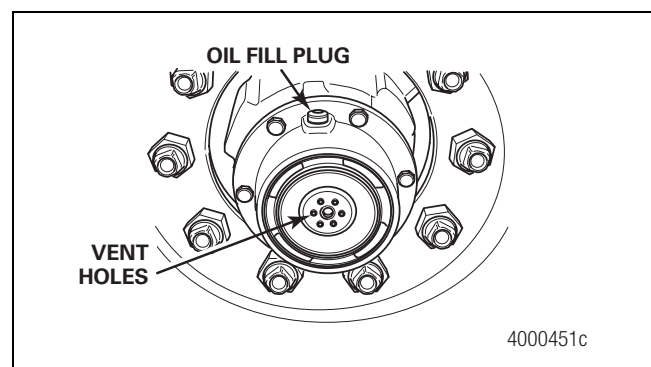

Figure 2.42

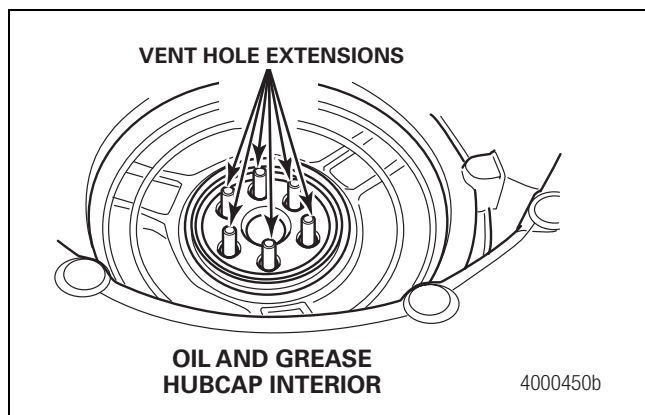

Figure 2.43

The through-tee assembly consists of the tube, tee vent, deflector shield and tee. Figure 2.44.

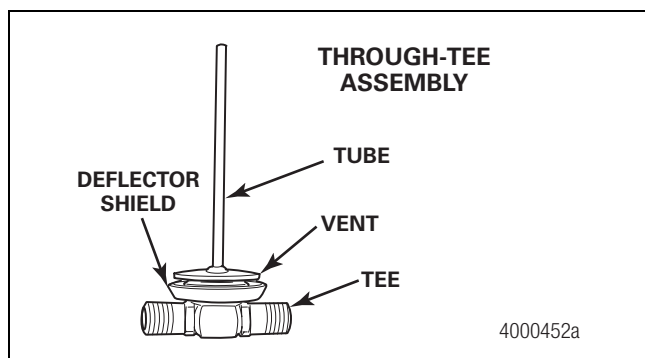

Figure 2.44

⚠ WARNING

Verify that the vent holes in a greased wheel end are not blocked with grease. Blocked vent holes will prevent system air from venting from the wheel end. Serious personal injury and damage to components can result.

1. Follow the manufacturer's instructions to install the hubcap. For oil-lubricated wheel ends, locate the oil fill plug on the top. Verify that the vent holes in a greased wheel end are not blocked with grease. Blocked vent holes will prevent system air from venting from the wheel end. Figure 2.42.
2. Use your fingers to check that there is no debris on the tube. Figure 2.45.

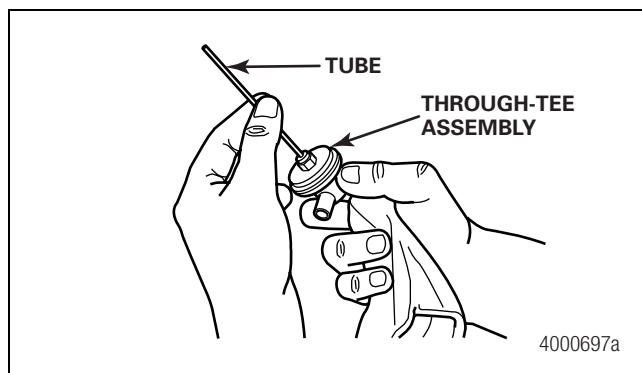

Figure 2.45

3. Carefully install the through-tee assembly STRAIGHT into the hubcap to insert the tube into the stator. When you insert the tube into the stator, it's normal to feel some resistance when the tube contacts the stator O-ring. Figure 2.46.

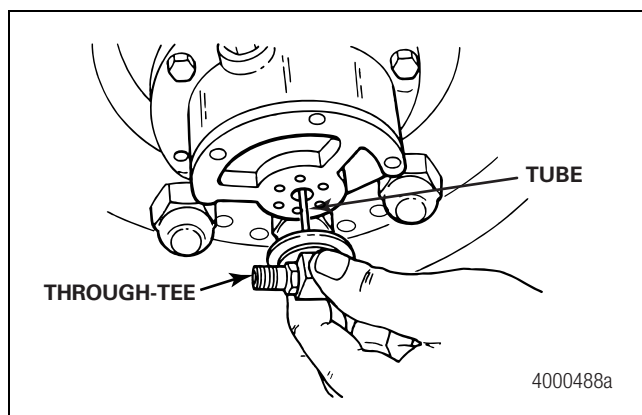

Figure 2.46

⚠ CAUTION

Do not overtighten the through-tee assembly during installation. Damage to the component threads can result.

4. Hand-tighten the through-tee assembly. Tighten the tee with a torque wrench set at 45 lb-in (5 N•m). Check alignment of the tee air fittings to the tire valve stems. If aligned, go to Step 6. If not aligned, retighten the tee with a torque wrench set to 55 lb-in (6 N•m) and tighten until aligned. Do not exceed 55 lb-in (6 N•m). If still not aligned, go to Step 5. Figure 2.47.



2 Assembly and Installation

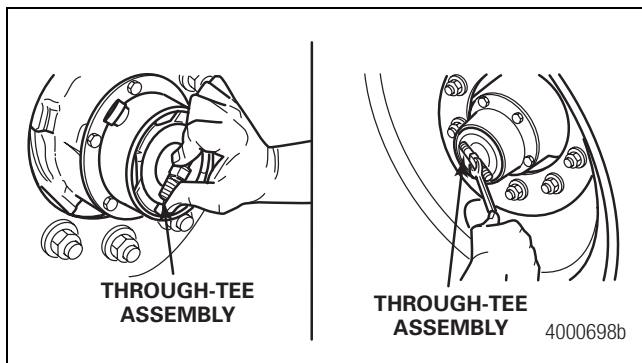

Figure 2.47

5. The air fittings must point TOWARD the tire valve stems. Check that the tire valve stems are 180 degrees opposite each other. The valve stems must be in this position to install the tire inflation system. Figure 2.48. If necessary, bolt-on hubcaps or wheels may be “clocked” to align the through-tee with the tire valve stems. Screw-on hubcaps may be rotated for this alignment, as long as the hubcap tightening specification is within the hubcap manufacturer’s recommended guidelines.

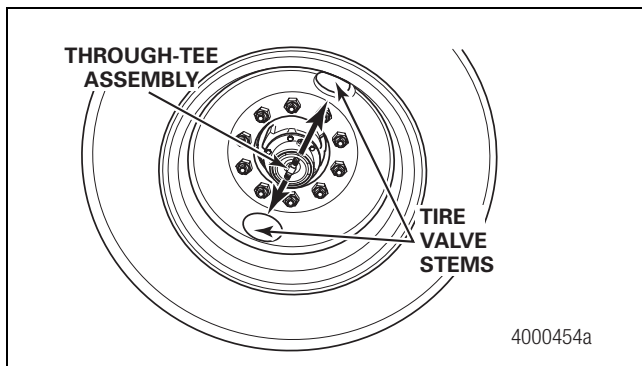

Figure 2.48

⚠ CAUTION

During installation, hand-tighten the tire inflation system hoses to the tire valve stems, then use a wrench to tighten the hoses to the correct specification. Do not overtighten the connection, this may damage the hose seal and cause a tire to deflate when the trailer is parked. Damage to components can result.

6. Hand-tighten the tire inflation system hoses to the tire valve stems. Then use a 7/16-inch wrench to tighten the connections an additional half-turn. Figure 2.49.

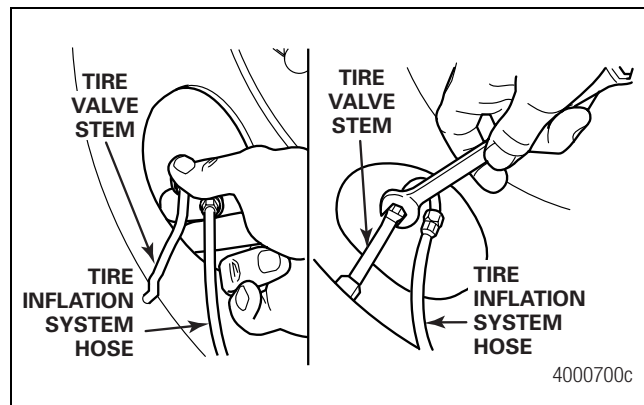

Figure 2.49

Air Components

Control Box

⚠ WARNING

A standard MTIS can have a control box with either a black flow sensing switch or a grey flow sensing switch. Both control boxes mount to the trailer in the same way. However, MTIS equipped with a ThermALERT™ system must have a control box with a grey flow sensing switch, which is more sensitive to air flow than the black switch.

If a ThermALERT™ system has a control box with a black flow sensing switch, replace it with a control box that has a grey switch. Otherwise, the indicator light may not come ON if a wheel end overheats. Serious personal injury and damage to components can result.

It is important to note that there are two different control boxes. One is for the standard MTIS, and the other is for the MTIS with the ThermALERT™ system.

The control box for the standard MTIS can include a flow sensing switch that is either black or grey. The control box for the MTIS with the ThermALERT™ system must include a grey flow sensing switch. Both control boxes mount to the trailer in the same way.

The preferable location to install the tire inflation system control box is the ROADSIDE REAR of the subframe facing the REAR of the trailer. Mount the control box in a location that’s accessible, free of hazards and positioned so the control box door can be opened.

Use the following procedure to mount the control box either to the supplied mounting bracket or directly to the trailer subframe. Check to ensure that the control box, electrical lines or air lines do not interfere with any suspension components in the system.

Mounting Bracket Installation

⚠ WARNING

Axle weld locations and welding procedures must adhere to Meritor standards. Welding at locations other than those authorized by Meritor will void the warranty and can reduce component fatigue life. Serious personal injury and damage to components can result.

Wear safe clothing and eye protection when you use welding equipment. Welding equipment can burn you and cause serious personal injury. Follow the operating instructions and safety procedures recommended by the welding equipment manufacturers.

You can either weld or bolt the supplied mounting bracket to the trailer subframe.

1. Wear safe eye protection.
2. Park the vehicle on a level surface. Block the wheels to prevent the vehicle from moving.
3. Install the mounting bracket to position the control box as described in this section. Use one of the following installation procedures.
 - Weld the bracket to the subframe.
 - Use the supplied mounting bracket as a template and drill two 5/16-inch (0.80 cm) holes into the trailer subframe. Use the supplied fasteners, washers and locknuts to secure the bracket to the subframe. Figure 2.50 and Figure 2.51.

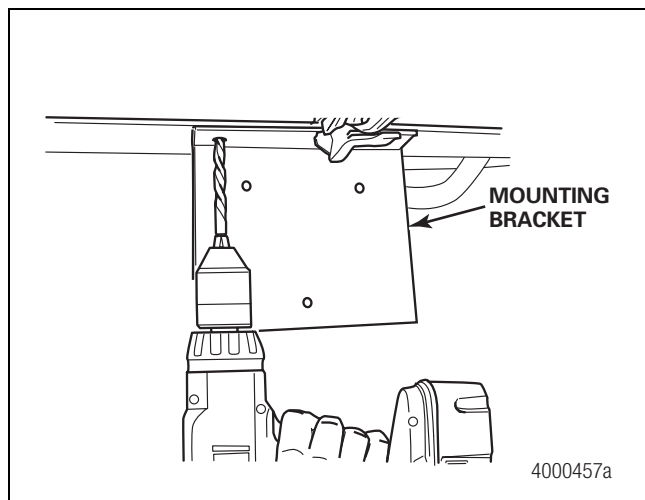

Figure 2.50

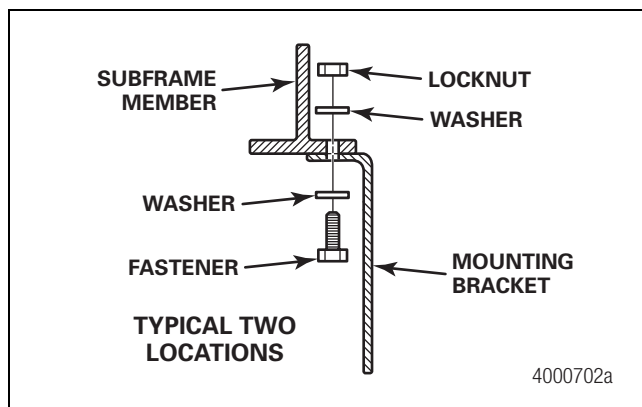

Figure 2.51

4. Install the control box to the mounting bracket using the supplied 1/4-inch (6.36 mm) fasteners, washers and locknuts. Figure 2.52 and Figure 2.53.

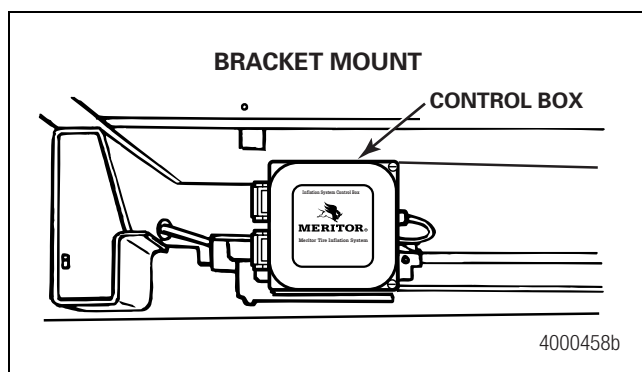

Figure 2.52

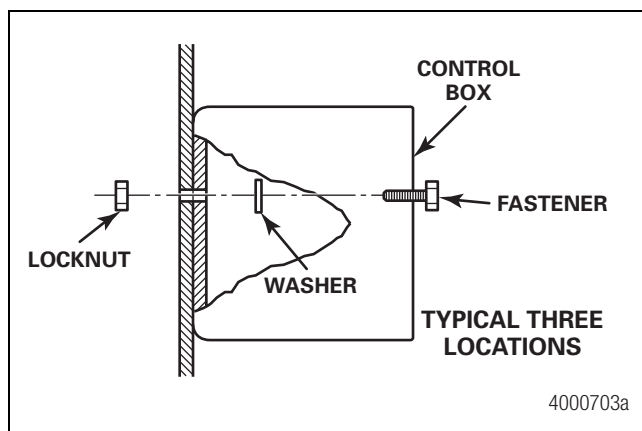

Figure 2.53

2 Assembly and Installation

Trailer Subframe Installation

1. Locate the control box as described in this section. Use the supplied mounting bracket as a template and drill three 1/4-inch (6.36 mm) holes into an appropriate mounting surface to position the control box as described in this section. Figure 2.54.

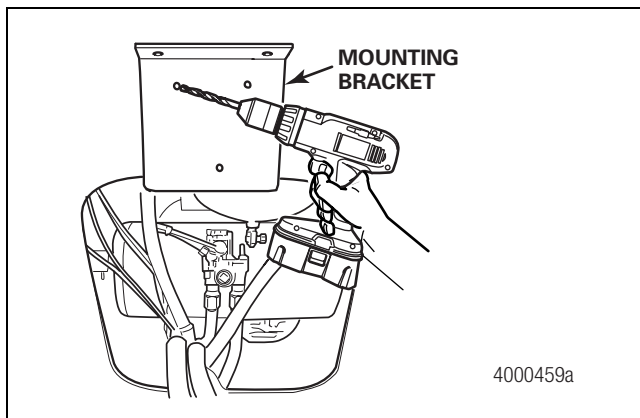

Figure 2.54

2. Discard the supplied mounting bracket. Use the supplied 1/4-inch (6.36 mm) fasteners, washers and locknuts to install the control box directly to the subframe. Figure 2.53 and Figure 2.55.

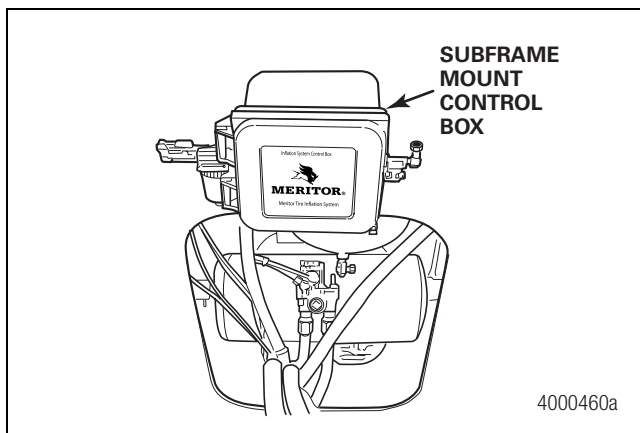

Figure 2.55

Pressure Protection Valve (PPV)

It is not necessary to apply a sealer when the PPV and installation nipple are first installed if the current production components have sealant pre-applied to the threads. If the parts are removed, however, apply a sealer such as Teflon® tape to the threads prior to reinstalling. Figure 2.56.

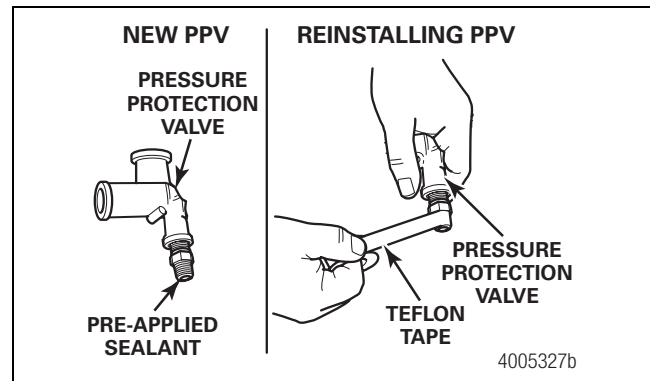

Figure 2.56

1. Drain the air from the trailer air system service tank.
2. Hand-tighten the installation nipple into a spare port in the air tank, preferably in the top half of the air tank. Then use an 11/16-inch wrench to tighten the nipple approximately two additional turns to obtain an airtight seal.
3. Hand-tighten the PPV into the installation nipple. Use a wrench to tighten the PPV approximately two additional turns to obtain an airtight seal. When correctly installed, the slotted screw in the PPV should face DOWN. Figure 2.57.

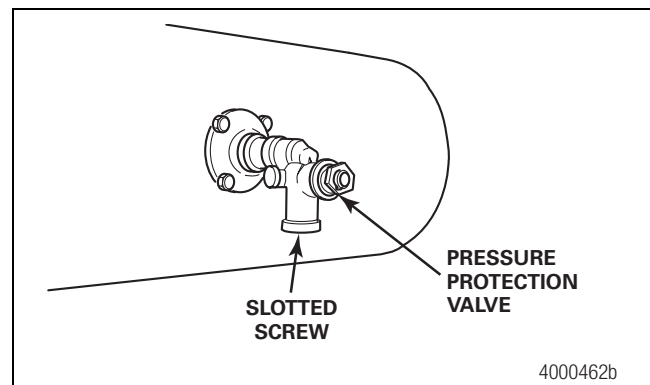

Figure 2.57

Air Lines

When you route the tire inflation system air lines, use grommets to protect them from contacting sharp edges at hole locations. Use tie wraps to secure them to the existing trailer brake air lines.

1. Route an air line from the PPV to the control box input port. Figure 2.58 and Figure 2.59. Hand-tighten the air line compression fittings, then use a 9/16-inch wrench to tighten them approximately one additional turn to obtain an airtight seal.

2 Assembly and Installation

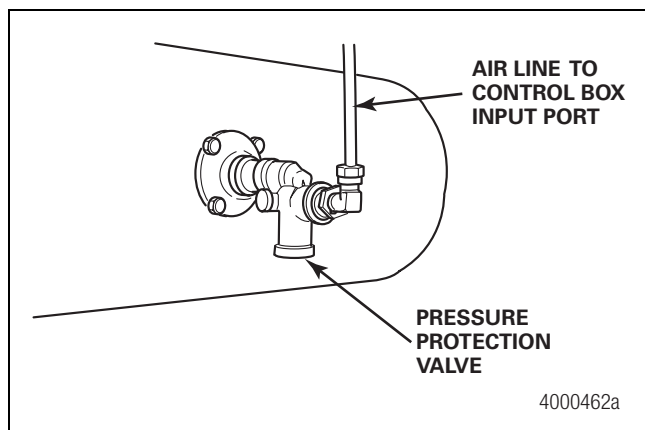

Figure 2.58

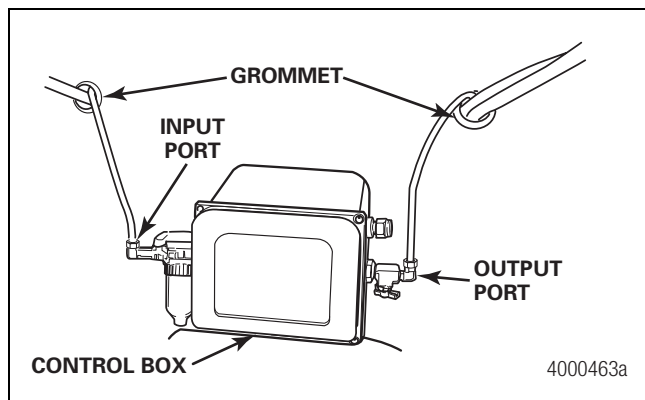

Figure 2.59

2. Route an air line from the control box output port to the air line tee. Suspend the tee AWAY from the trailer brake lines to protect these lines from damage. Figure 2.60. Hand-tighten the air line compression fittings, then use a 9/16-inch wrench to tighten them approximately one additional turn to obtain an airtight seal.

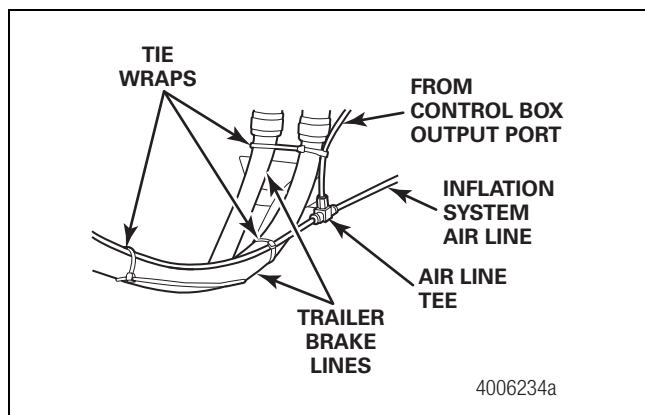

Figure 2.60

3. Route the air lines from the tee to the axle air fittings. Provide sufficient slack in the lines to allow for suspension movement. Use the slack in the existing trailer brake lines as a guide. Figure 2.61. Hand-tighten the air line compression fittings, then use a 9/16-inch wrench to tighten them approximately one additional turn to obtain an airtight seal.

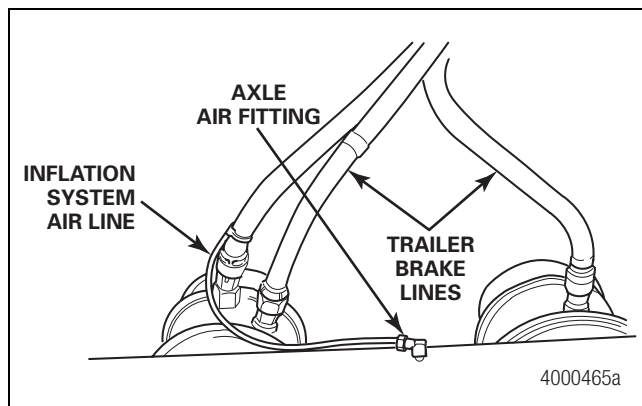

Figure 2.61

Electrical Components

⚠ WARNING

When working on an electrical system, the possibility of electrical shock exists, and sparks can ignite flammable substances. Always disconnect the battery ground cable before working on an electrical system to prevent serious personal injury and damage to components.

1. If the trailer is connected to the tractor, disconnect the battery ground cable. Connect the pigtail connectors to the electrical cable, and then to the indicator light. Figure 2.62.

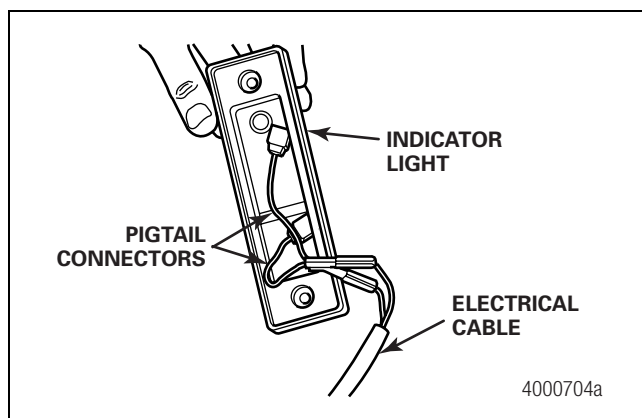

Figure 2.62

2 Assembly and Installation

- Mount the indicator light vertically onto the roadside front of the trailer, approximately 30-inches (76 cm) from the bottom of the coupler and as close as possible to the outside of the trailer. The driver should be able to see the indicator light from the roadside rear view mirror. If your trailer is equipped with the MTIS ThermALERT™ system, install the ThermALERT™ decal as close as possible to the indicator light. Figure 2.63.

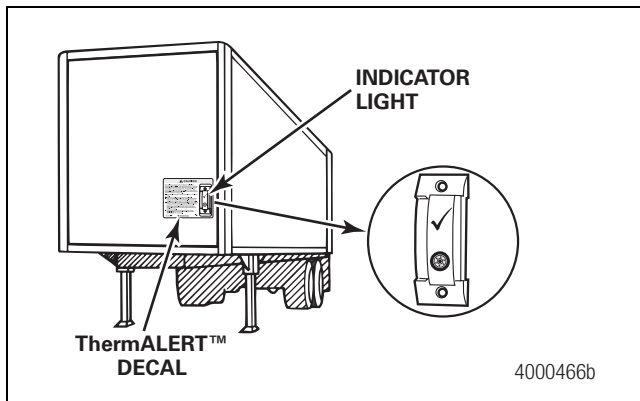

Figure 2.63

- Route a length of electrical cable from the indicator light to the trailer seven-way box. Figure 2.64.

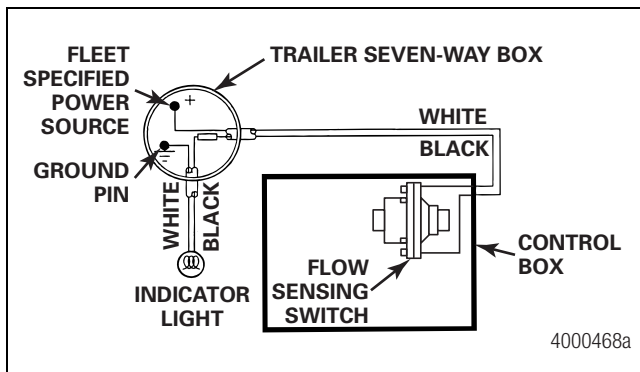

Figure 2.64

- Secure the electrical cable to the front of the trailer using the supplied P-clamps. Figure 2.65.

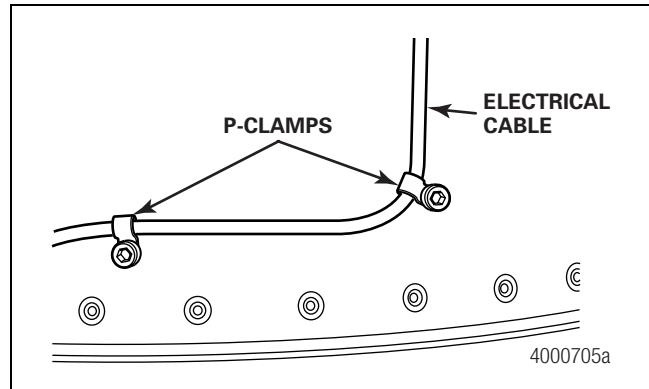

Figure 2.65

- Route the electrical cable from the trailer seven-way box to the tire inflation system control box. When you route the tire inflation system electrical cable, use grommets to protect it from contacting sharp edges at hole locations. Use tie wraps to secure the cable to the existing trailer air and electrical lines. Figure 2.64.

- If the trailer is equipped with a sliding subframe:**

Provide sufficient slack in the cable to allow for suspension movement. Use the slack in the existing trailer brake lines as a guide.

- Connect the electrical cable to the electrical contacts of the flow sensing switch in the control box. The flow sensing switch will be black or grey in color for a standard MTIS. This switch **must** be grey if using the ThermALERT™ system. Figure 2.66.

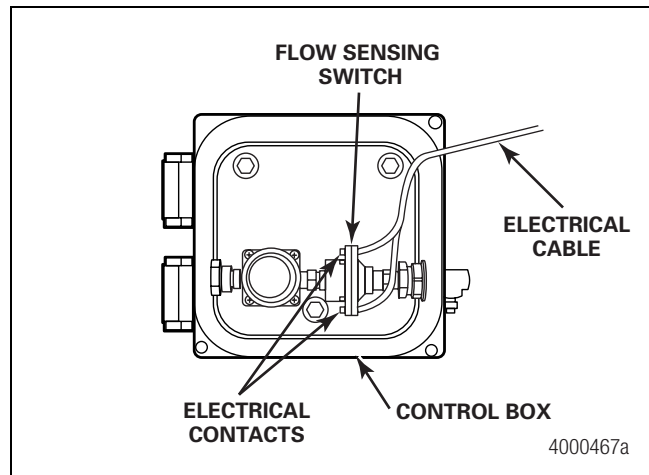

Figure 2.66

- In the trailer seven-way box, connect the supplied eye connectors to the white wires, one coming from the indicator light, one coming from the control box. Figure 2.67.

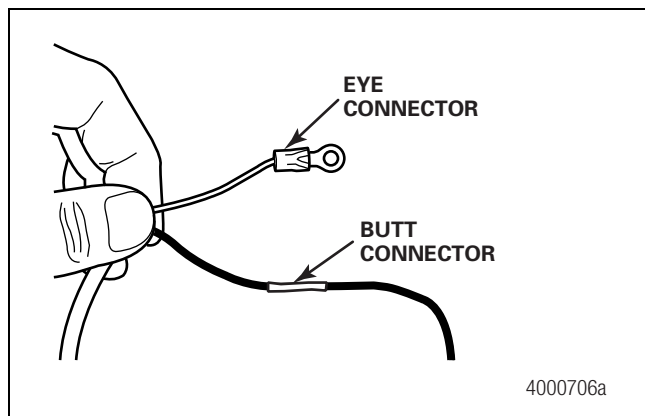

Figure 2.67

- In the trailer seven-way box, connect the white wire eye connector from the control box to a pin that will supply constant 12-volt power. The system must be tapped into a power source in the trailer seven-way box that will provide constant 12-volt power. The installer must decide which pin will supply this requirement. Connect the white wire from the light to the ground. Figure 2.64.
- In the trailer seven-way box, use the supplied butt connector to connect the black wire from the indicator light to the black wire from the control box. Figure 2.67.
- If necessary, reconnect the battery ground cable.

Wheel-End Oil

Refer to the trailer axle manufacturer literature for service instructions. For Meritor trailer axles, refer to Maintenance Manual 14, Trailer Axles. To obtain this publication, refer to the Service Notes page on the front inside cover of this manual.

If the wheel end is oil-lubricated, add oil through the hubcap fill plug to the manufacturer's recommended level. The oil level must be below the level of the six hubcap wheel-end vents. Figure 2.68 and Figure 2.69.

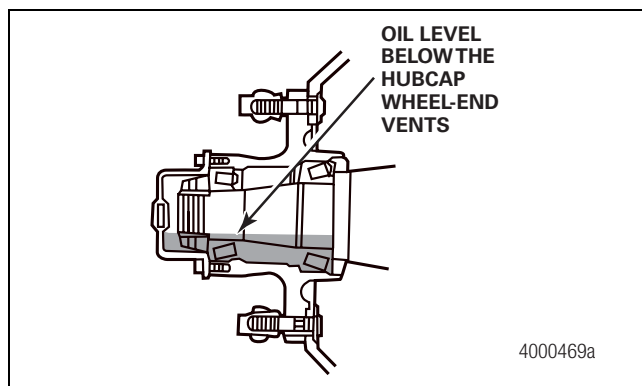

Figure 2.68

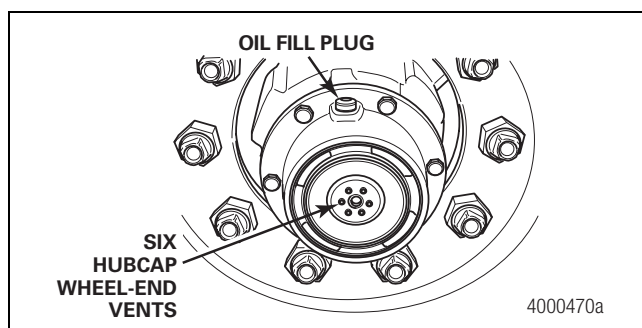

Figure 2.69

Standard MTIS and ThermALERT™ System Decals

Identification and information decals are used with the tire inflation system.

- Install an identification and hose installation decal on each side of the trailer above the suspension. Figure 2.70.

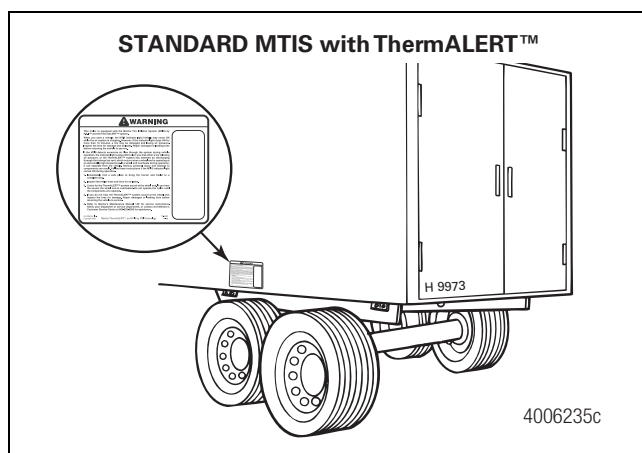

Figure 2.70

2 Assembly and Installation

2. Install the indicator light decal below the light. Figure 2.71 or Figure 2.72.

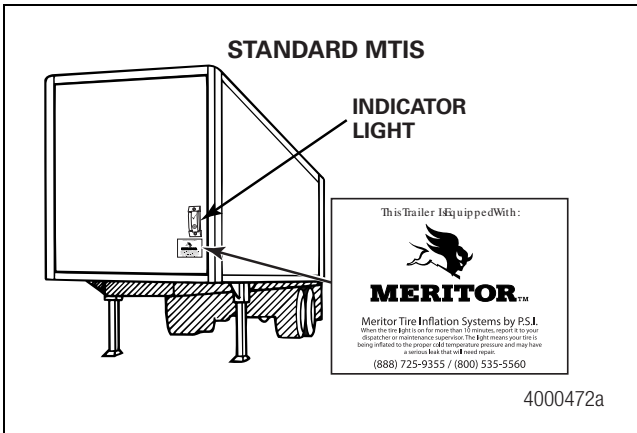

Figure 2.71

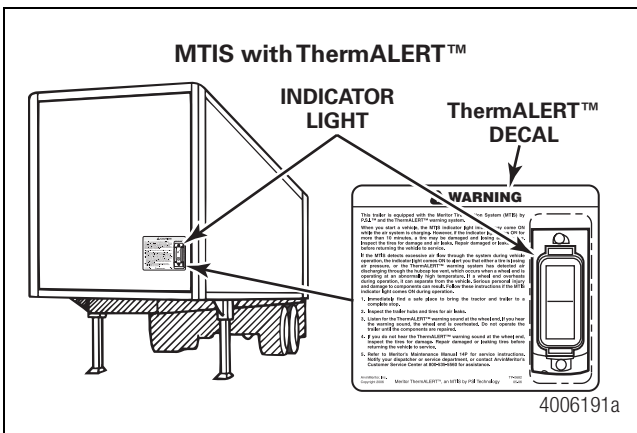

Figure 2.72

3. If equipped with a ThermALERT™ system, install ThermALERT™ decals to each hubcap. Figure 2.73.

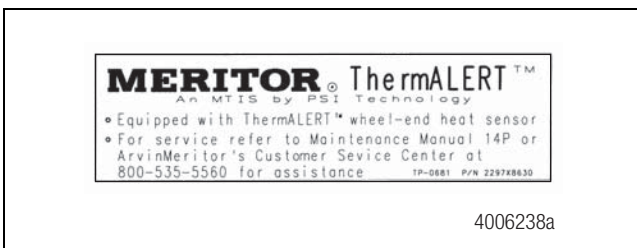

Figure 2.73

Hazard Alert Messages

Read and observe all Warning and Caution hazard alert messages in this publication. They provide information that can help prevent serious personal injury, damage to components, or both.

⚠ WARNING

To prevent serious eye injury, always wear safe eye protection when you perform vehicle maintenance or service.

Check System Operation

Use the following procedure to check the tire inflation system for correct operation. This inspection ensures that the system is activated, the indicator light works, the hoses are installed correctly and that the system delivers the correct pressure to the tires.

1. Wear safe eye protection.
2. Check that the shut-off valve is ON. When the valve is ON, the knob aligns with the shut-off valve body. Also, check that the petcock is closed. Figure 3.1.

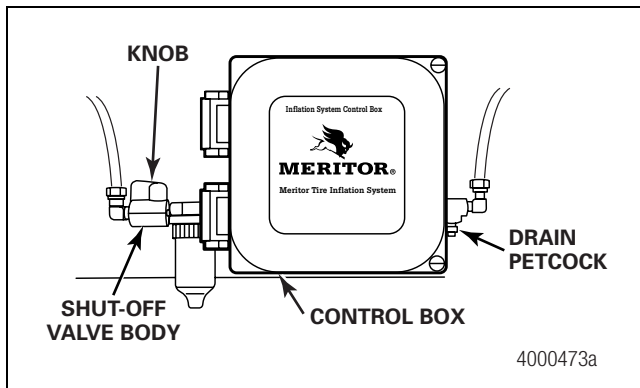

Figure 3.1

3. The tire inflation system must be fully pressurized before proceeding. This may take up to 10 minutes, since the axles, tires and possibly the brake system will have to be pressurized. A shop air source will charge the system more quickly than a tractor compressor.

Fully pressurize the tire inflation system by connecting the trailer to a pressure source that can deliver 120-130 psi (827-896 kPa) to the trailer gladhands. Allow the air pressure source sufficient time to pressurize the system, which may take up to 10 minutes.

Check all fittings and the hubcap tee vent with soapy water for air leaks.

4. Connect a 12-volt power source to the trailer seven-way box. Figure 3.2.

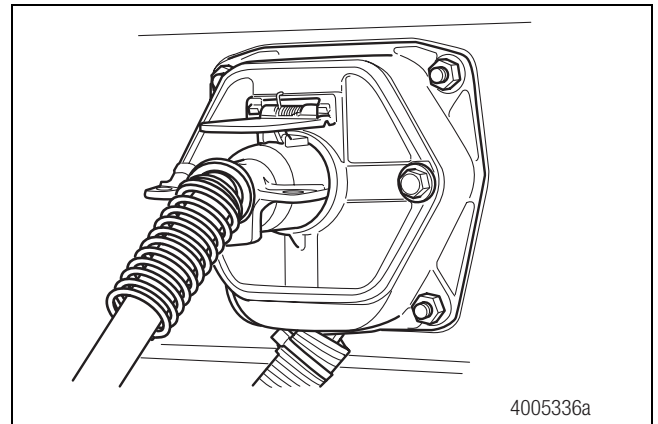

Figure 3.2

5. Check all of the through-tees by pushing a short piece of tire inflation system air line into the through-tee. Air should flow from the through-tees. Figure 3.3.

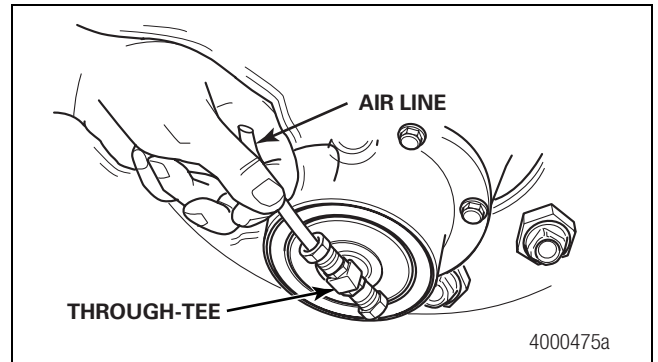

Figure 3.3

6. Check that the indicator light comes ON as air flows from the through-tee and turns off when the air flow stops. Figure 3.4.

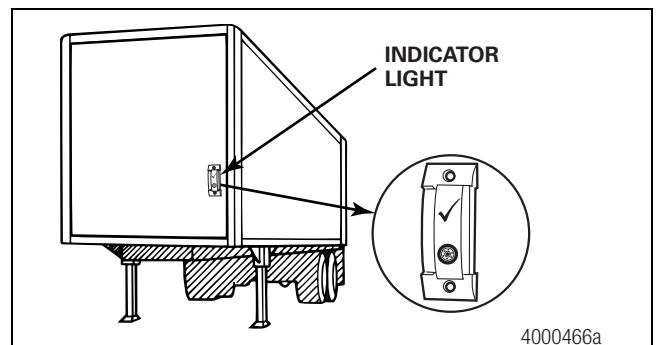

Figure 3.4

3 Check System Operation

7. Push on the valve cores at the ends of the hoses attached to the tires. Air should flow from the tires. Figure 3.5.

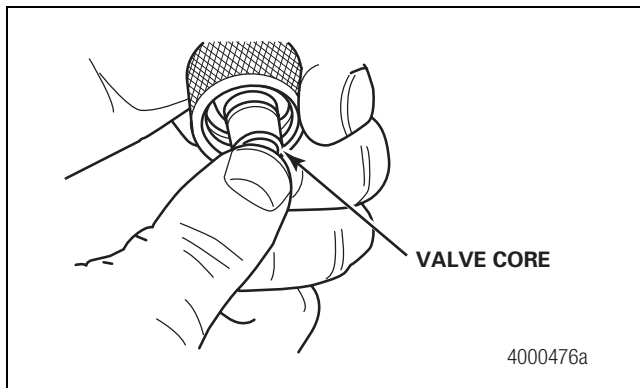

Figure 3.5

8. Use the valve cores in the hoses to reduce pressure in all the tires 5 to 10 psi below the desired tire pressure. A sticker located inside the control box door indicates the tire pressure that the inflation system will deliver. Figure 3.6. For example, if the fleet runs 100 psi (689 kPa), reduce the tire pressure to 90 to 95 psi. Figure 3.5.

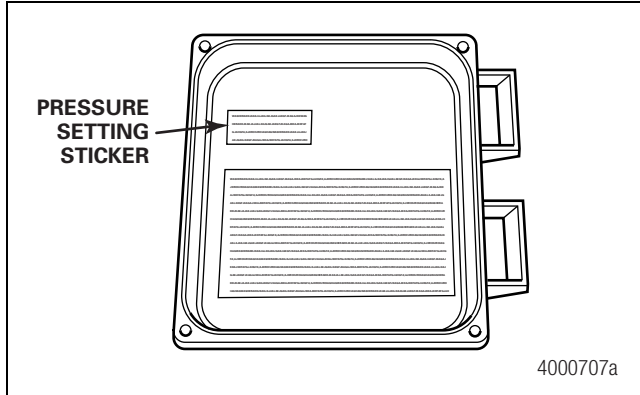

Figure 3.6

9. Choose a tire to test. Hand-tighten the hose to the through-tee. Figure 3.7.

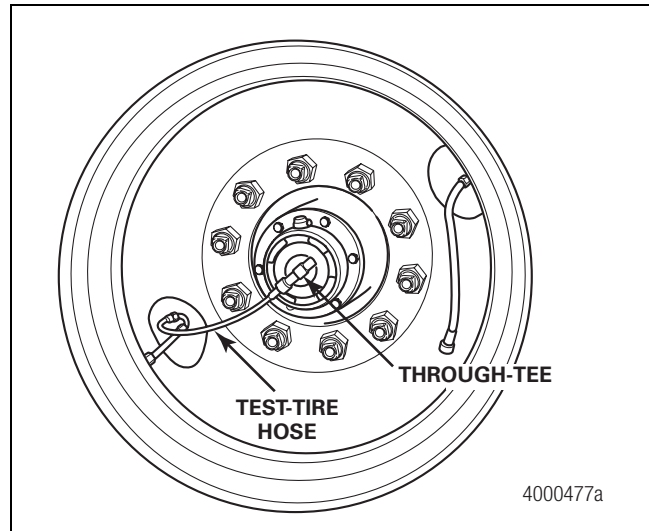

Figure 3.7

10. Allow sufficient time for the pressure to build up in the test-tire. This may take up to 20 minutes, depending on system pressure and other vehicle air requirements.
11. Disconnect the test-tire hose from the through-tee. Check the test-tire pressure using an accurate air pressure gauge. Tire pressure should equal the system pressure setting on the decal in the control box. Figure 3.8.

- **To increase the tire pressure:** Pull the system adjustment knob out, then turn the knob **CLOCKWISE** approximately 1/8 turn (45 degrees). Hand-tighten the hose to the through-tee. Do not use pliers. Repeat Step 10 and Step 11. When complete, lock the knob by pushing it inward. Figure 3.9.
- **To decrease the tire pressure:** Reduce the pressure on the test-tire 5 to 10 psi below the desired air pressure. Pull the system adjustment knob out, then turn the knob **COUNTERCLOCKWISE** approximately 1/8 turn (45 degrees). Hand-tighten the hose to the through-tee. Do not use pliers. Repeat Step 10 and Step 11. When complete, lock the knob by pushing it inward. Figure 3.9.

3 Check System Operation

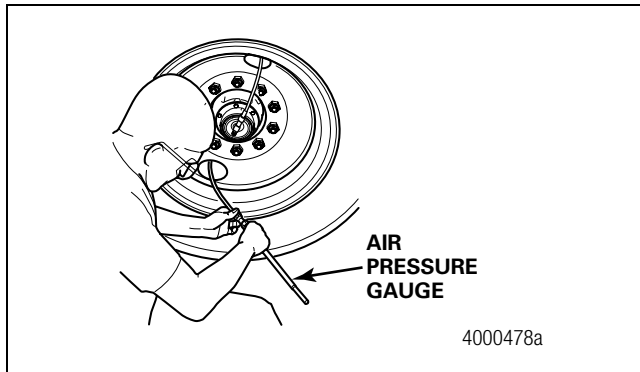

Figure 3.8

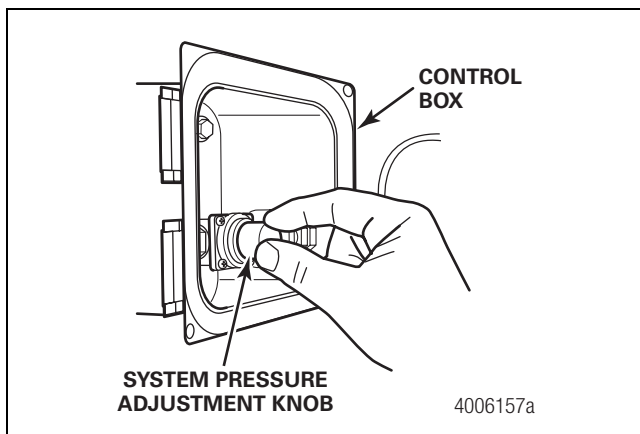

Figure 3.9

12. When the test-tire pressure is correct, hand-tighten the remaining tire hoses to the through-tees. Do not use pliers. The tire inflation system will inflate all of the tires to the specified pressure. At this point, the system is fully assembled. Figure 3.10.

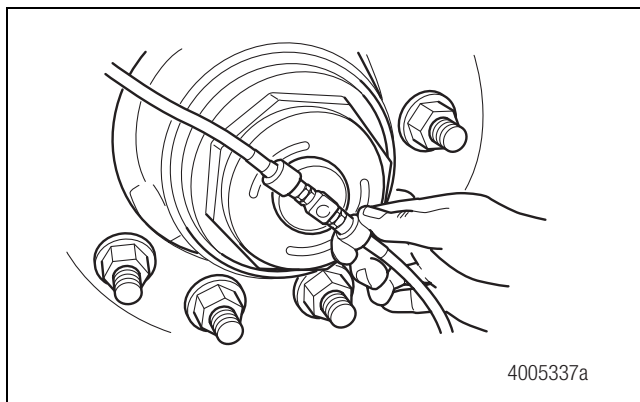



Figure 3.10

13. Check the wheel ends to verify that the tire inflation system hoses do not contact the wheels. Figure 3.11.

- **If a hose contacts a wheel:** Use a wrench to slightly rotate the through-tee to reposition the hose away from the wheel. Ensure the through-tee is still tightened to the hubcap at 45-55 lb-in (5.1-6.2 N•m). 

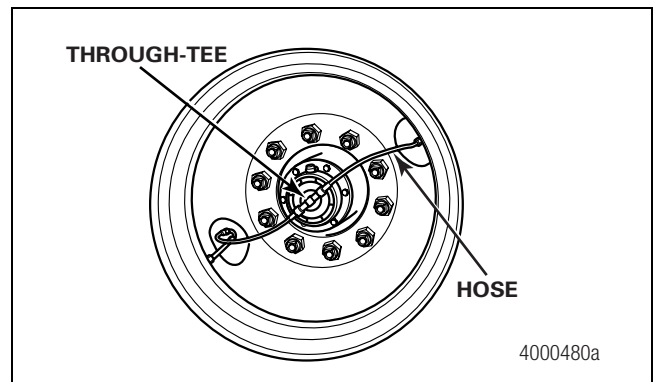

Figure 3.11

Check the Control Box Pressure

Use the following procedure to check the tire inflation system control box delivery pressure, if the pressure in the tires is different than the pressure value specified on the control box door label. This procedure will help determine whether the tire pressure difference is from incorrect control box settings or other issues, such as a system leak downstream from the control box.

1. Turn the tire inflation system off using the shut-off valve at the control box.
2. Drain all the air from the system using the drain petcock at the control box.
3. Remove the outlet air line from the control box. Figure 3.12.

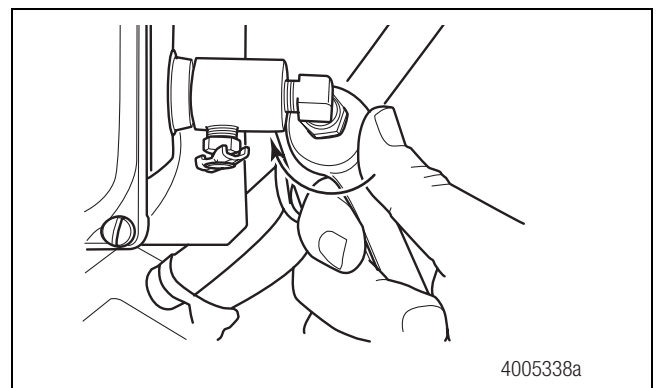

Figure 3.12

3 Check System Operation

4. Attach an air pressure test gauge fixture to the outlet port of the control box. Figure 3.13. Refer to Section 8 for information on building an air pressure test gauge fixture. Figure 3.14.

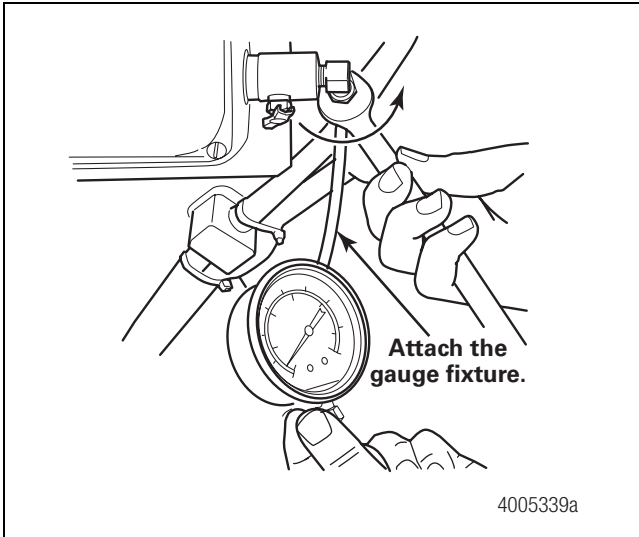

Figure 3.13

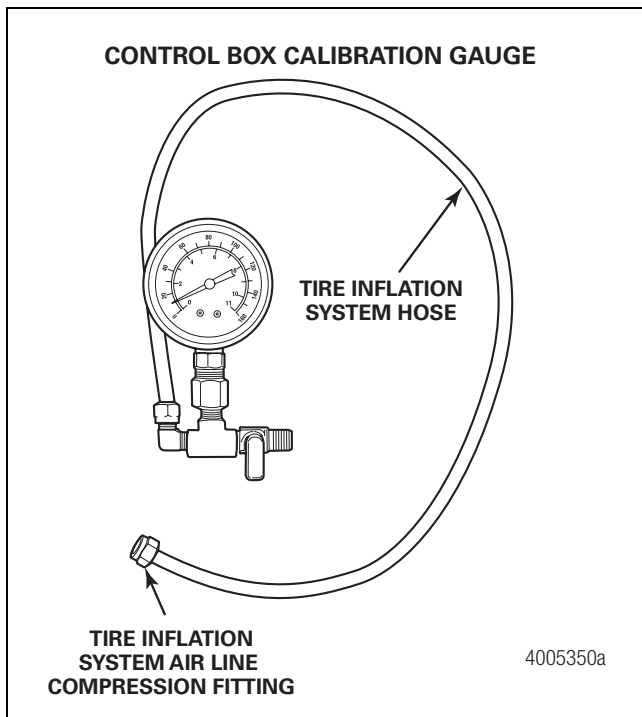

Figure 3.14

5. Close the drain petcock at the control box.
6. Turn the tire inflation system ON using the shut-off valve at the control box.
7. Compare the reading of the air pressure gauge to the pressure value marked on the door of the control box. The air pressure gauge should read three psi (0.21 bar) higher than the pressure value mark on the door of the control box. Figure 3.15.

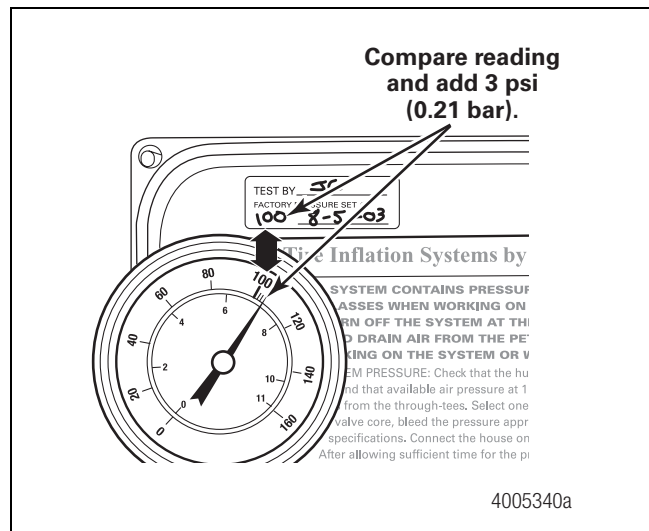

Figure 3.15

8. If the air pressure is incorrect, adjust the pressure regulator. First pull out the control knob, then turn the control knob in approximate 1/8-turn (45 degrees) increments. Figure 3.16. Turn the knob CLOCKWISE to increase pressure or COUNTERCLOCKWISE to decrease pressure.

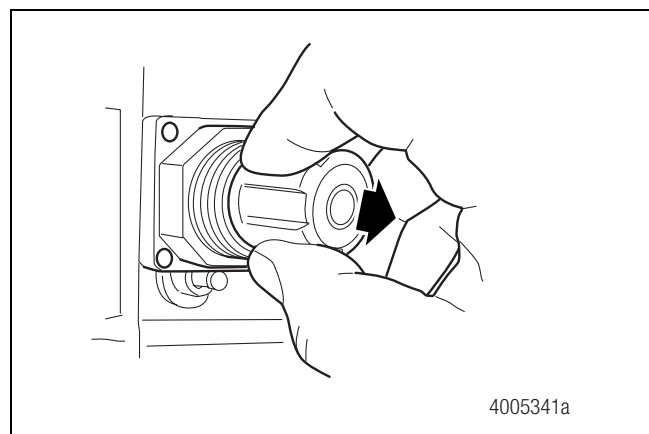

Figure 3.16

9. Check that the air pressure gauge reading is three psi (0.21 bar) higher than the pressure value marked on the door of the control box. Figure 3.17.

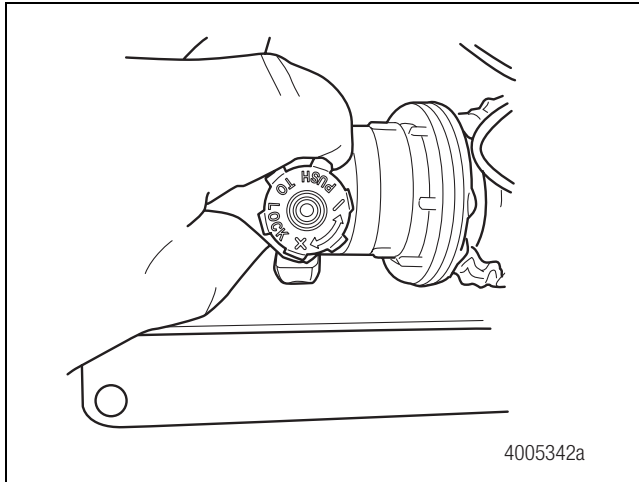

Figure 3.17

10. Once the pressure is set, lock the control knob by pushing it in.
11. Turn the tire inflation system off using the shut-off valve at the control box.
12. Drain all the air from the system using the drain petcock at the control box.
13. Replace the air line to the outlet port.
14. Close the drain petcock, and turn the system on using the shut-off valve.

Check the Hose Connections for Leaks

Use the following procedure to check for and correct system leaks from the tire inflation system fittings and hose connections.

CAUTION

Test the tire inflation system for air leaks before you place the vehicle into service. Spray a soap-and-water solution on all fittings and connections. Listen for audible leaks and check for bubbles. If you detect a leak, identify the source and replace parts as required. Air leaks in the tire inflation system can cause damage to components during operation.

1. Test the tire inflation system for air leaks. Spray a soap-and-water solution on all fittings and hose connections to check for leaks. Figure 3.18 and Figure 3.19.

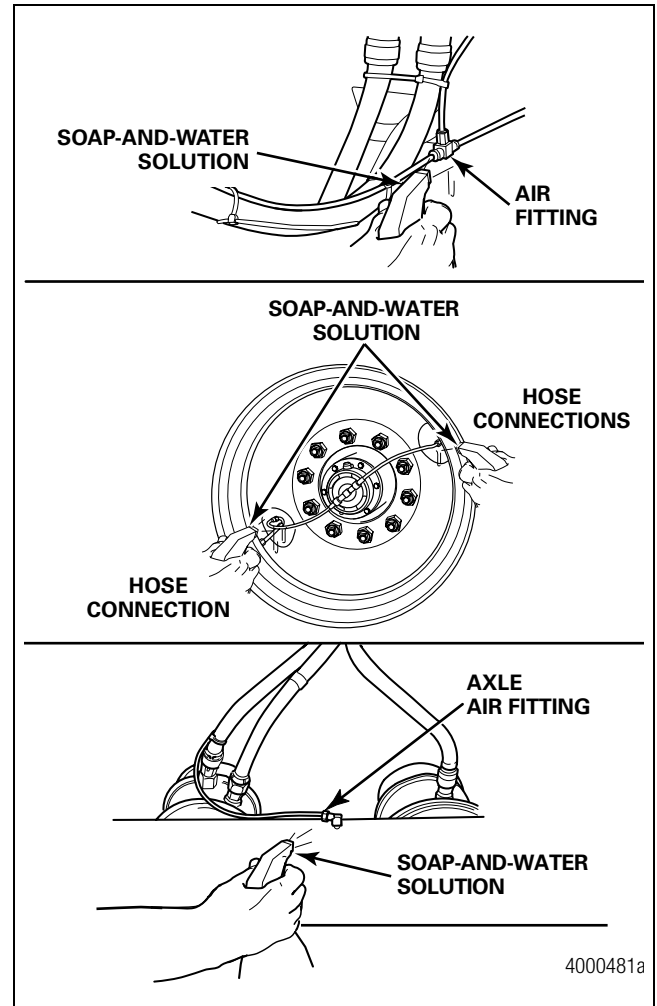

Figure 3.18

3 Check System Operation

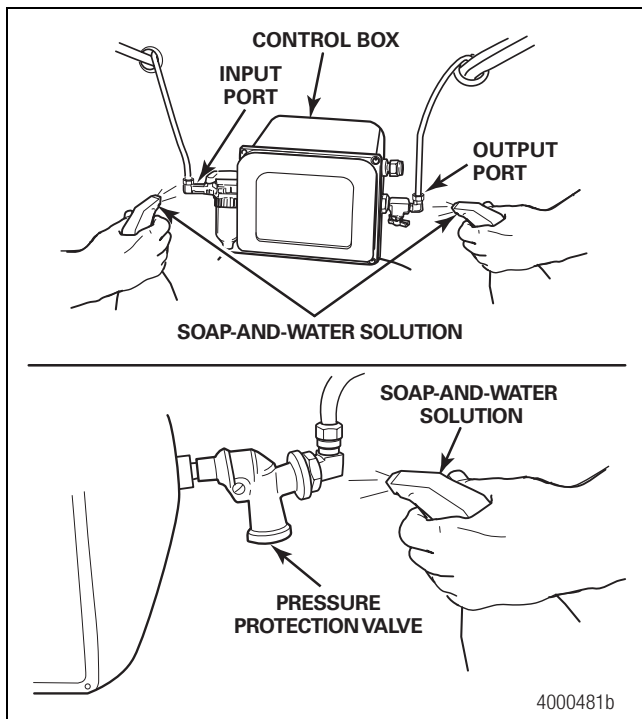

Figure 3.19

2. Look for bubbling and listen for audible leaks.
3. Tighten or replace fittings that leak.

Check the Wheel End for Air Leaks

Use the following procedure to check for, and correct, system air leaks from the tire inflation system components located at the wheel end, including the hoses, through-tee, stator and press plug.

1. Spray a soap-and-water solution to check the hose to the through-tee connection and the hubcap vent for leaks. Figure 3.20.

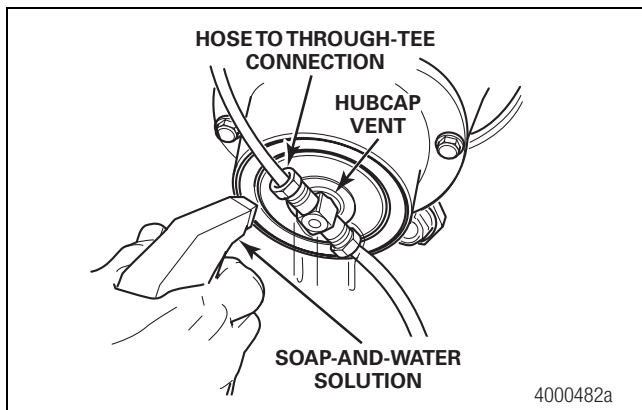

Figure 3.20

2. Look for bubbling and listen for audible leaks.

- **If the hubcap vent is leaking:** The through-tee, stator or press plug is leaking. Use the following procedure to investigate further. Refer to the instructions in this manual for the following steps.

- A. Turn the tire inflation system off using the shut-off valve at the control box.
- B. Drain all the air from the system using the drain petcock at the control box.
- C. Remove the hoses from the through-tee. Then remove the through-tee and hubcap.
- D. Cover the wheel end with a clean towel to protect the bearings from contaminants.
- E. Insert the through-tee into the stator and hold it in place.
- F. Turn the system ON.
- G. Ensure to hold the tee straight into the axle. Spray the press plug area with a soap-and-water solution to check for leaks. Figure 3.21.

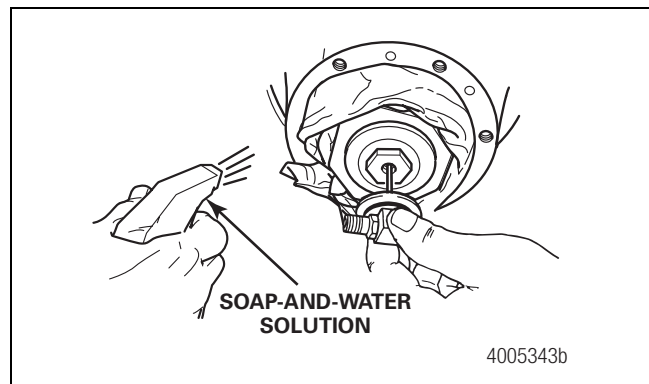



Figure 3.21

- H. Look for bubbling and listen for audible leaks.
- **If the through-tee is leaking:** Replace it with a new part. Go to Step L.
 - **If the stator is leaking:** Either tighten the stator or replace it with a new part. Go to Step L.
 - **If the press plug is leaking:** Replace the press plug with a new part. Go to Step J.
 - **If your system has the ThermoALERT™ system upgrade and the thermal screw is leaking:** Replace the thermal screw by using the following steps.

3 Check System Operation

- I. Remove the thermal screw with a 5/32-inch (4 mm) Allen-head socket. Figure 3.22.
 - Remove the sealing washer.
 - Inspect the sealing surface in the spindle plug for debris.
 - Install a new sealing washer on a new thermal screw.
 - Install the thermal screw into the spindle plug and tighten to 25-30 lb-in (2.82-3.39 N•m). 

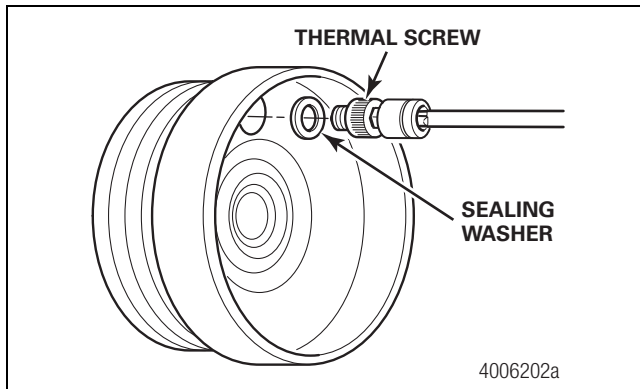

Figure 3.22

- J. Use a slide hammer fitted with the press plug removal tool to remove the leaking press plug. Use care not to score the inside diameter of the spindle bore. Figure 3.23.

A slide hammer and press plug remover is available from Meritor to help remove the press plugs. Refer to Section 8. Figure 3.24.

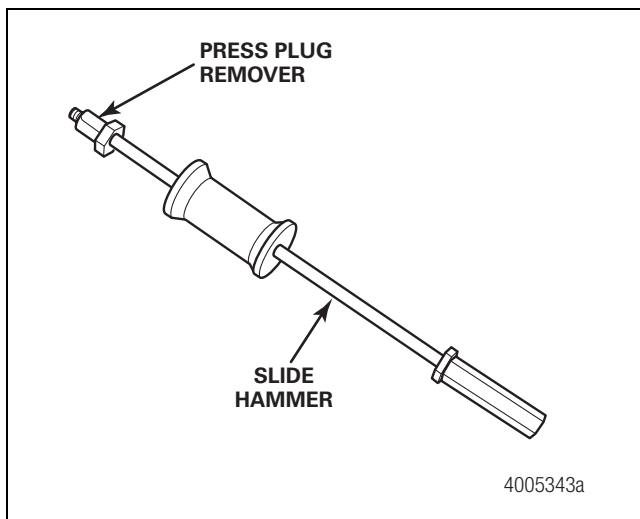

Figure 3.23

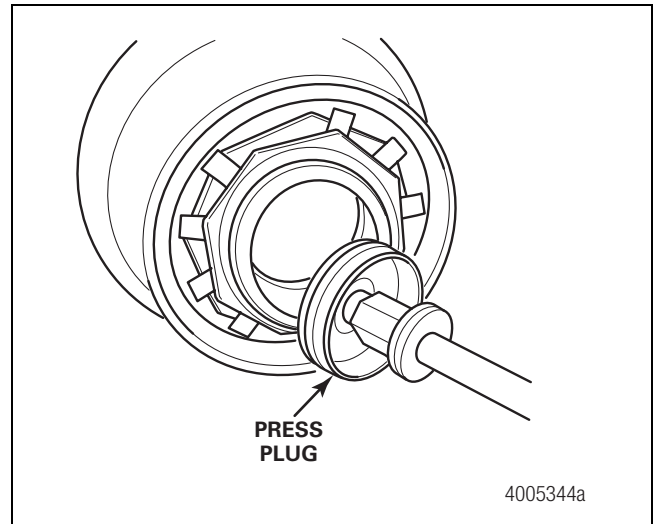

Figure 3.24

- K. Install a new press plug. Refer to the instructions in this manual.
- L. Reassemble the wheel end and tire inflation system components. Refer to the instructions in this manual.

4 Pre-Service Check

Hazard Alert Messages

Read and observe all Warning and Caution hazard alert messages in this publication. They provide information that can help prevent serious personal injury, damage to components, or both.

⚠ WARNING

To prevent serious eye injury, always wear safe eye protection when you perform vehicle maintenance or service.

Pre-Service Check

After receiving a trailer and before placing it in service, check the tire inflation system to ensure it operates correctly.

1. Wear safe eye protection.
2. Check that the trailer has the correct air supply (120-130 psi [827-896 kPa]) and the system is connected to a 12-volt power source.
3. Check that the shut-off valve is ON. When the valve is ON, the knob aligns with the shut-off valve body. Ensure that the drain petcock is closed. Figure 4.1.

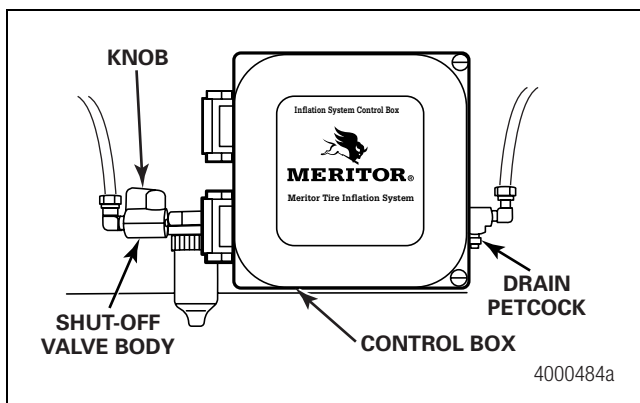

Figure 4.1

4. Check the indicator light by opening the drain petcock at the control box. The light will come ON to indicate that it's operating correctly. Figure 4.2.
 - If the indicator light is not operating correctly: Refer to Section 7.

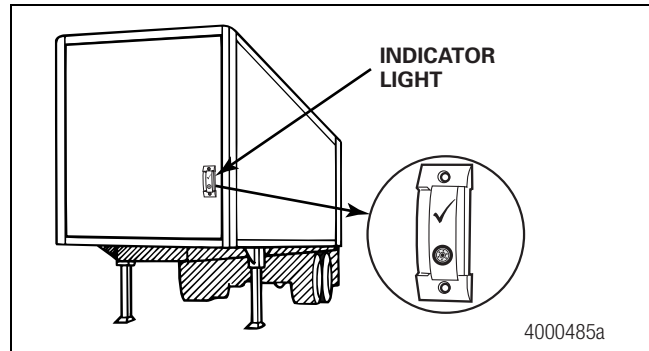

Figure 4.2

5. Use an accurate air pressure gauge to check the tire pressure at the system hoses. Figure 4.3.
 - If the tire pressure is not correct: Refer to Section 7.

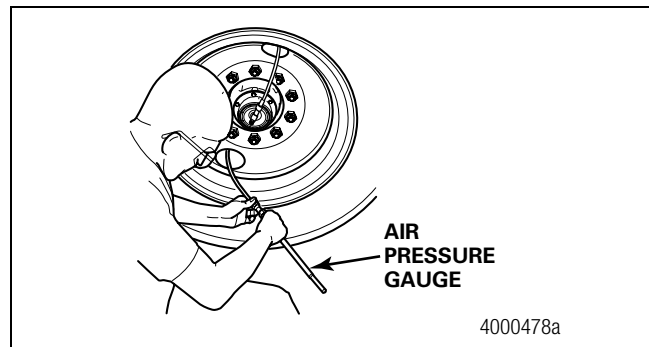

Figure 4.3

6. Use a soap-and-water solution to check the hose-to-valve stem connections, hose-to-through-tee connections and hubcap vents for leaks. Figure 4.4. Repair or replace parts as required. Refer to Section 3.

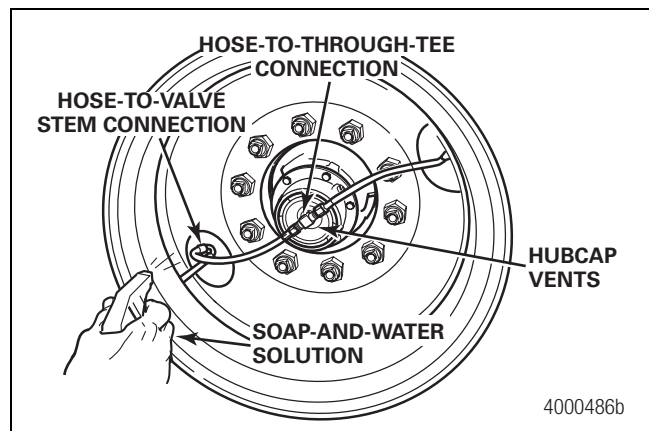



Figure 4.4

7. Check the wheel ends to verify that the tire inflation system hoses do not contact the wheels. Figure 4.5.
 - **If a hose contacts a wheel:** Use a wrench to slightly rotate the through-tee to reposition the hose away from the wheel. Ensure the through-tee is still tightened to the hubcap at 45-55 lb-in (5.1-6.2 N•m). 

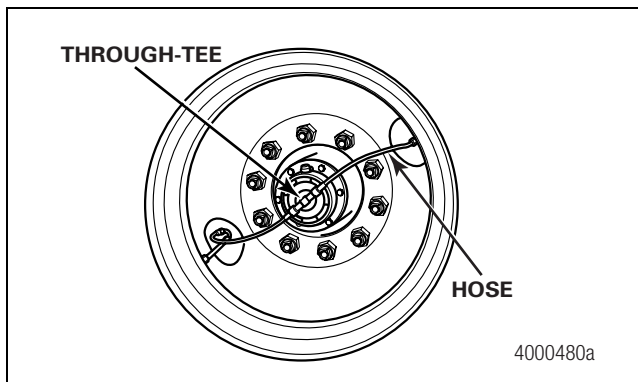

Figure 4.5

5 Inspection and Maintenance

Hazard Alert Messages

Read and observe all Warning and Caution hazard alert messages in this publication. They provide information that can help prevent serious personal injury, damage to components, or both.

⚠ WARNING

To prevent serious eye injury, always wear safe eye protection when you perform vehicle maintenance or service.

Tire Inflation System Inspection Interval Guidelines

Tire inflation system inspection intervals depend on factors such as the environment, mileage, and loading. For example, container chassis service is a light-duty application, because it usually involves an on-highway environment and low mileage. Light-duty applications require extended inspection intervals.

Dump trailer service is a heavy-duty application, because it usually involves an off-highway environment and heavy loading. Heavy-duty applications require reduced inspection intervals.

Installation of a ThermALERT™ system does not eliminate the need to perform recommended wheel-end maintenance. Inspect the tire inflation system components listed here for correct operation on the following schedule.

General

Inspect the system wheel-end components whenever you remove a tire.

Light-Duty Service

Inspect the system every 100,000 miles or 24 months, whichever comes first.

Standard-Duty Service

Inspect the system every 100,000 miles or 12 months, whichever comes first.

Heavy-Duty Service

Inspect the system every 50,000 miles or six months, whichever comes first.

Inspect the following components for correct operation at the recommended inspection intervals. Refer to Section 3 for inspection instructions.

- Indicator light
- Tire hose valve cores
- Tire pressure
- Tire hose-to-wheel interference
- Tire hose-to-valve stem connections
- All air line fitting connections from the pressure protection valve to the axle air fitting
- Hubcap vents
- Self-draining filter. Figure 5.1.

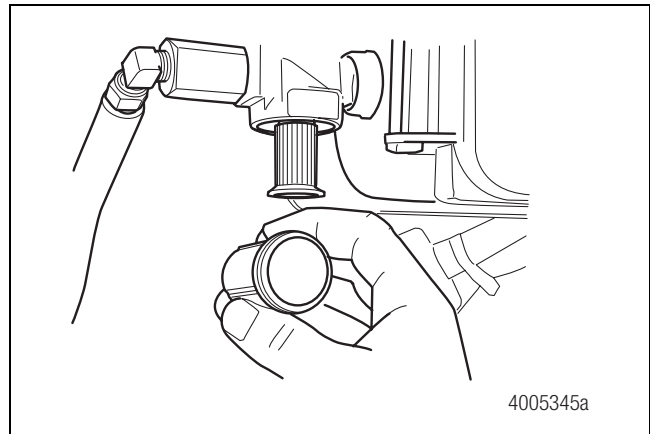

Figure 5.1

Inspection

Indicator Light

If the indicator light comes ON during operation, the driver should immediately find a safe place to pull over, stop and assess the problem. Inspect the tires and tire inflation system components for leaks. Refer to Section 3. Repair as necessary. Figure 5.2.

The warning light illumination can be caused by one of the following reasons:

- Damaged inflation system components
- System unable to keep up with a leaking tire.
- Wheel-end temperature is high enough to activate the ThermALERT™ system.

In the event the ThermALERT™ system has been activated, an audible sound of air escaping from the hubcap vent will alert the driver to the problem wheel end.

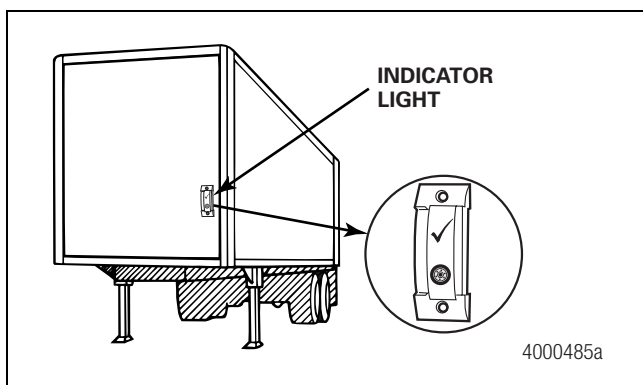

Figure 5.2

During initial system charging, the indicator light will come ON and remain ON for up to 10 minutes, depending on the system pressure setting and other vehicle air requirements.

- **If the indicator light remains ON for more than 10 minutes during initial system charging:** Refer to Section 7.

6 Maintenance

Inspection

Tires

Check the Tire Pressure

Although the tire inflation system can charge a leaking tire during vehicle operation, Meritor recommends that you inspect tires for wear and damage at regular intervals, and check tire pressure at regular intervals as follows.

1. Remove the tire inflation system hose at the through-tee. Figure 6.1.

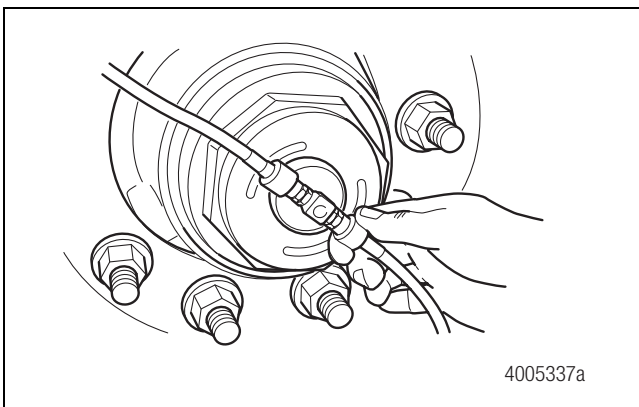

Figure 6.1

2. Press the tire pressure gauge to the hose and read the pressure. The end of the tire inflation system hose incorporates a standard tire valve fitting. Figure 6.2.
 - **If the tire pressure is correct:** Reconnect the hose to the through-tee by hand-tightening the knurled fitting. Do not tighten with pliers.
 - **If the tire pressure is not correct:** Refer to Section 7.

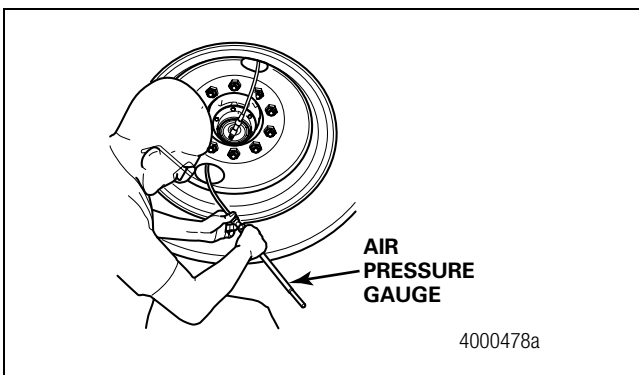

Figure 6.2

Change the Tire Inflation System Pressure Setting

If you need to change the tire inflation system pressure setting, refer to Section 3.

Component Removal and Installation

Turn the System OFF

⚠ WARNING

The tire inflation system uses compressed air. Turn the system OFF and drain the system at the petcock before you perform maintenance or service to avoid serious personal injury and damage to components.

1. Turn the shut-off valve OFF at the control box to stop air delivery to the system. When the shut-off valve is OFF, the knob is perpendicular to the valve body. Figure 6.3.

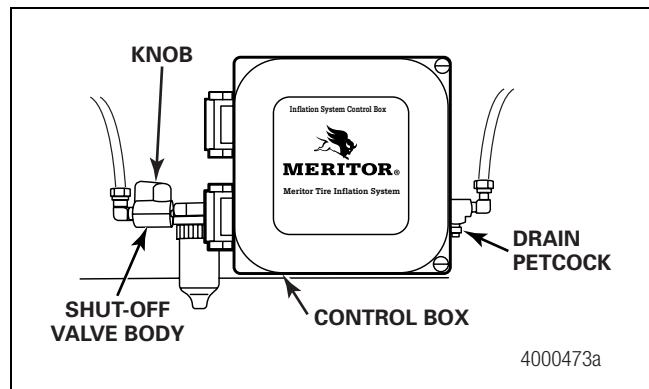

Figure 6.3

2. Turn the drain petcock to open it and drain the pressurized air from the system. Figure 6.3.

Remove and Replace the Tires

⚠ WARNING

Park the vehicle on a level surface. Block the wheels to prevent the vehicle from moving. Support the vehicle with safety stands. Do not work under a vehicle supported only by jacks. Jacks can slip and fall over. Serious personal injury and damage to components can result.

1. Raise the trailer until the tires are off the ground. Place safety stands under the trailer frame or under each trailer axle spring seat. Do not support the vehicle only by jacks. Figure 6.4.

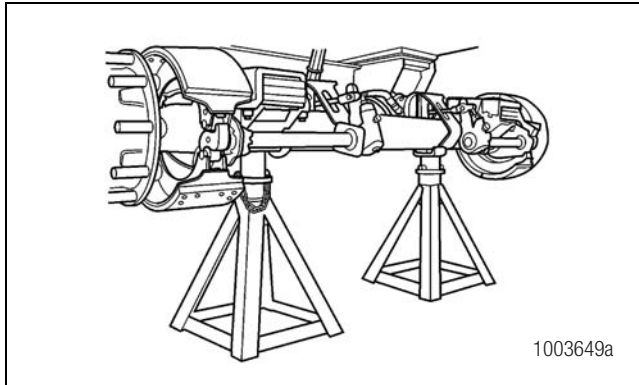

Figure 6.4

2. Remove the tire inflation system hoses.
3. Use a wheel dolly and pull the tire and wheel assembly STRAIGHT off the hub. A wheel dolly will help protect the through-tee when you remove and replace the tire and wheel assembly. Figure 6.5.
 - **If a wheel dolly isn't available:** Meritor recommends that you prevent damage to the through-tee by turning the system OFF using the drain petcock and shut-off valve as described in this section. Remove the through-tee, and then remove the tire and wheel assembly.



Figure 6.5

4. Service the tire.
5. Follow the wheel manufacturer's instructions to reinstall the wheels. Verify that the through-tee fittings point TOWARD the tire valve stems to ensure that you'll be able to correctly route the tire inflation system hoses. Figure 6.6.

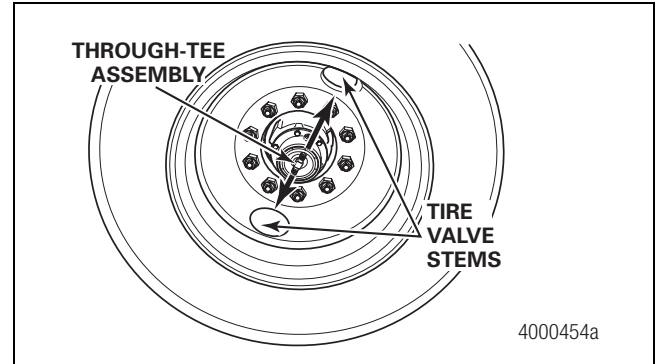

Figure 6.6

6. Install the tire inflation system hoses to the tire valve stems. Refer to Section 2 of this manual.
7. Reduce tire pressure 5-10 psi (0.034-0.069 MPa) below the fleet's tire pressure specification.
8. Hand-tighten the hoses to the through-tee. Do not use pliers. The tire inflation system will charge the tires to the specified tire setting.
9. Check the hoses for leaks. Refer to Section 3.

Hose Valve Cores

⚠ CAUTION

Only install Meritor original equipment parts when you service the tire inflation system. Non-original equipment parts will fit the system, but can prevent correct air pressure from being delivered to a leaking tire during operation. Damage to components can result.

Tire inflation system hoses are designed to operate with valve cores that open at three psi (0.02 MPa) pressure. Only install Meritor original equipment valve cores when you replace this part on a tire inflation system hose. Valve cores not manufactured by Meritor will fit tire inflation system hoses, but these valve cores can affect the pressure delivered to the trailer tires. Figure 6.7 and Figure 6.8.

6 Maintenance

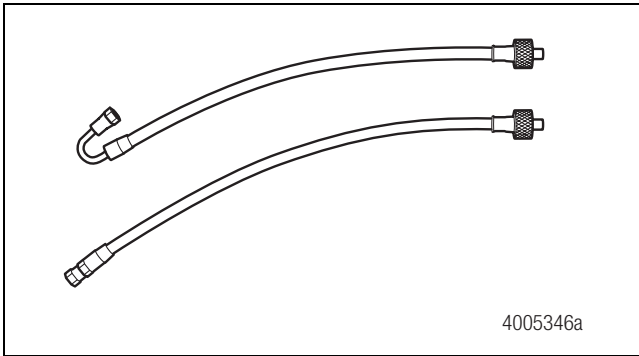

Figure 6.7

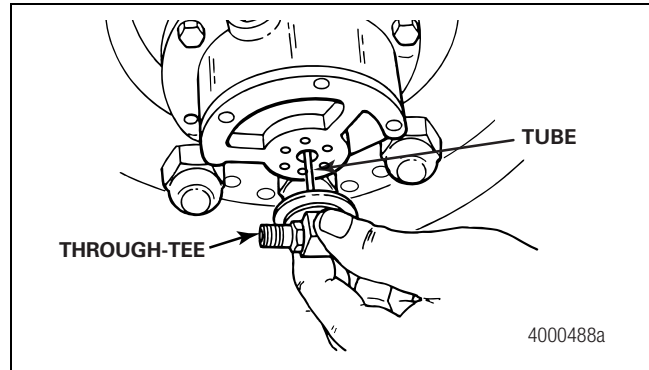

Figure 6.9

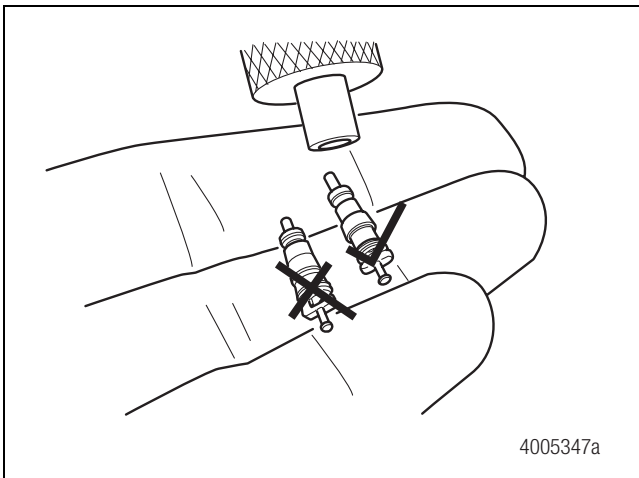

Figure 6.8

Remove the Through-Tee Before Installing a Hubcap

⚠ CAUTION

Do not bend or damage the through-tee tube when removing and installing a hubcap. A bent through-tee tube can cause the tire inflation system to leak. Damage to components can result.

Remove the through-tee before you remove or install a hubcap to prevent bending or damaging the through-tee tube, which can cause the tire inflation system to leak. Figure 6.9.

ThermALERT™ Heat-Sensing Screw Removal and Installation Instructions

⚠ WARNING

If the ThermALERT™ system activates during vehicle operation, you must repair or replace components that caused the wheel end to overheat before returning the vehicle to service. You also must install a new thermal screw, which is not reusable. Otherwise, the indicator light will continue to remain ON during vehicle operation, even though the wheel end has been repaired. If you ignore the indicator light, and another wheel end overheats during operation, serious personal injury and damage to components can result.

1. Remove the activated heat-sensing thermal screw using a 5/32-inch (4 mm) Allen key. Figure 6.10.

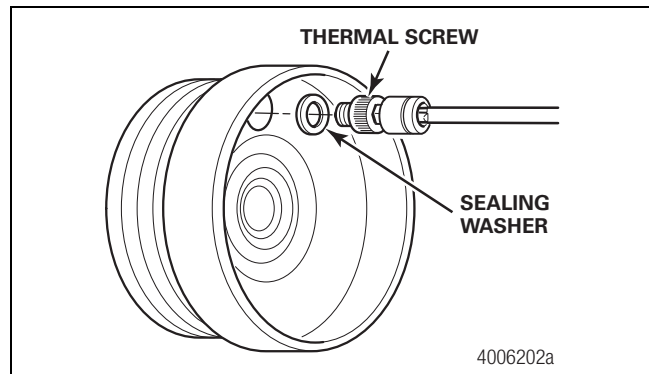



Figure 6.10

2. Remove the sealing washer.
3. Inspect the sealing surface in the spindle plug for debris.
4. Install a new sealing washer on a new thermal screw.
5. Install the thermal screw into the spindle plug and tighten to 25-30 lb-in (2.82-3.39 N•m). 

Hazard Alert Messages

WARNING

To prevent serious eye injury, always wear safe eye protection when you perform vehicle maintenance or service.

Diagnostics

Table A

Condition	Possible Causes	Actions
The indicator light is ON.	The system is delivering air during initial system charging.	The system is functioning correctly.
	The system is delivering air to a leaking tire.	Repair the tire.
	The system is delivering air to a leaking system component.	Repair the system component.
	The system is delivering air to a cracked axle.	Repair the axle.
	The system wiring is incorrect.	Correct the system wiring.
The indicator light is ON and air is leaking from the wheel-end tee vent.	The trailer is equipped with MTIS ThermALERT™ system and the wheel end is hot.	The system is functioning correctly. Repair and replace wheel-end components.
	The system is delivering air to a leaking system component.	Repair the system component.
	The through-tee is leaking.	Replace the through-tee.
	The stator O-ring is leaking.	Replace the stator.
	The stator threads are leaking.	Seal the stator threads.
	The press plug is leaking.	Replace the press plug.
	The trailer is not supplied with 12-volt power.	Supply 12-volt power to the trailer.
The indicator light is OFF during system operation.	The indicator light is inoperative.	Replace the indicator light.
	The flow sensing switch is inoperative.	Replace the flow sensing switch.
	The system wiring is damaged.	Repair the system wiring.
	The system wiring is incorrect.	Correct the system wiring.
	The trailer is equipped with MTIS ThermALERT™ system, the wheel end is hot and the control box has an incorrect flow switch.	Repair and replace the wheel-end components. Replace the flow switch in the control box with a grey color flow switch.
	The through-tee is leaking.	Replace the through-tee.
	The stator O-ring is leaking.	Replace the stator.
Air is leaking from the wheel-end tee vent.	The stator threads are leaking.	Seal the stator threads.
	The press plug is leaking.	Replace the press plug.
	The shut-off valve is off.	Turn on the shut-off valve.
Tire pressure is low.	The system pressure setting is too low.	Increase the system pressure setting.
	The incorrect valve cores are installed.	Replace the valve cores with Meritor original equipment.

7 Troubleshooting

Table A

Condition	Possible Causes	Actions
Lubricant is leaking from the wheel-end vent.	The wheel end is overfilled with lubricant.	Fill the wheel end to the correct level.
	A hubcap without vent extensions is installed onto an oil-lubricated wheel end.	Install a hubcap with vent extensions.
	The through-tee is leaking.	Replace the through-tee.
	The stator O-ring is leaking.	Replace the stator.
	The stator threads are leaking.	Seal the stator threads.
Tire pressure is high.	The press plug is leaking.	Replace the press plug.
	The tire is manually over inflated.	Reduce the tire pressure. The system will inflate to the correct level.
	The system pressure setting is too high.	Lower the system pressure setting.
The trailer tire deflates when parked.	The system hose or tire valve stem connection is leaking.	Correctly tighten the connection or replace the seals.
	The hose valve core is leaking.	Clean or replace the hose valve core.
	The tire is leaking.	Repair the tire.

Tire Inflation System

Refer to the following tables for tools and supplies used to service the tire inflation system.

To obtain these tools and supplies, refer to Service Notes page on the front inside cover of this manual.

Spindle Bore Polishers	Part Number	Supplier
Dana/Eaton D22	3T524	Grainger
Hendrickson HN	3T524	
Holland Trade	3T524	
Ingersoll F-22	3T524	
Meritor TN/TQ/TK	3T524	
Sudisa 12R/11M	3T524	
Dana/Eaton P22	3T534	
Hendrickson HP	3T534	
Hendrickson TP	3T534	
Holland Propar	3T534	
Meritor TP/TB/WP	3T534	

Press Plug Drive Adaptors	Part Number	Supplier
Holland Propar	51011-01	Meritor
Dana/Eaton D22	51011-02	
Hendrickson HN	51011-02	
Meritor TN/TQ/TK	51011-02	
Sudisa 9M	51011-09	
Sudisa 12R	51011-03	
Sudisa 11M	51011-04	
Holland Trade	51011-05	
Hendrickson TP	51011-06	
Meritor TP/TB	51011-06	
Meritor WP	51011-07	
Meritor TB Retrofit (Old Style)	51011-14	
Meritor Europe LM	61051-00	
Meritor TL	61051-00	
Dana P-22	51011-13	
Hendrickson HP	51011-13	
Ingersoll F-22	51011-08	
Ingersoll F-24	N/A	

Specialty Tools and Supplies	Part Number	Supplier
System Pressure Test Gauge	81014-00	Meritor
Drill Jig — Solid Spindle	81023-00	
Tap Guide	81023-10	
Slide Hammer Kit	81044-00	
Welsh Plug Removal Spear	81044-01	
Press Plug Remover	81044-02	
Press Plug Drive Handle	51011-10	
Retaining Compound	32621-00	
Towelette	32632-00	
Bore Polishing Mandrel	3T564	
Straight Die Grinder	6Z562	

Cleaning Wand

Refer to Figure 8.1 to make a cleaning wand.

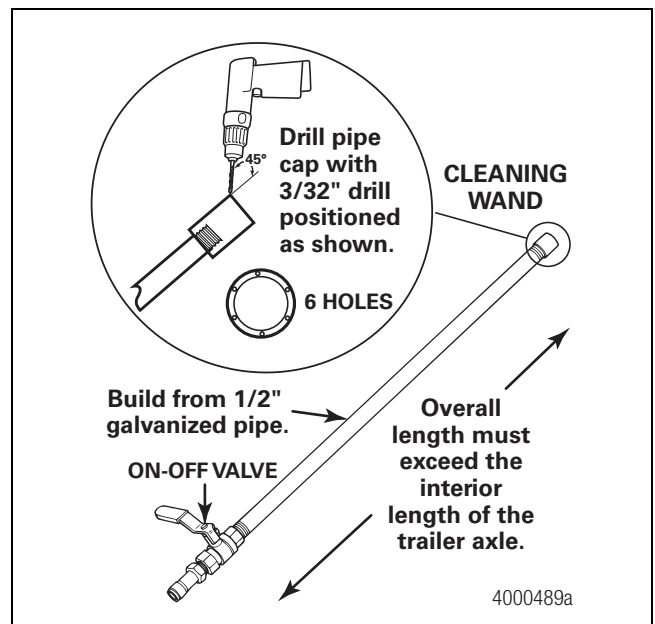

Figure 8.1

8 Special Tools

Tire Test Gauge

Refer to Figure 8.2 to assemble a tire test gauge.

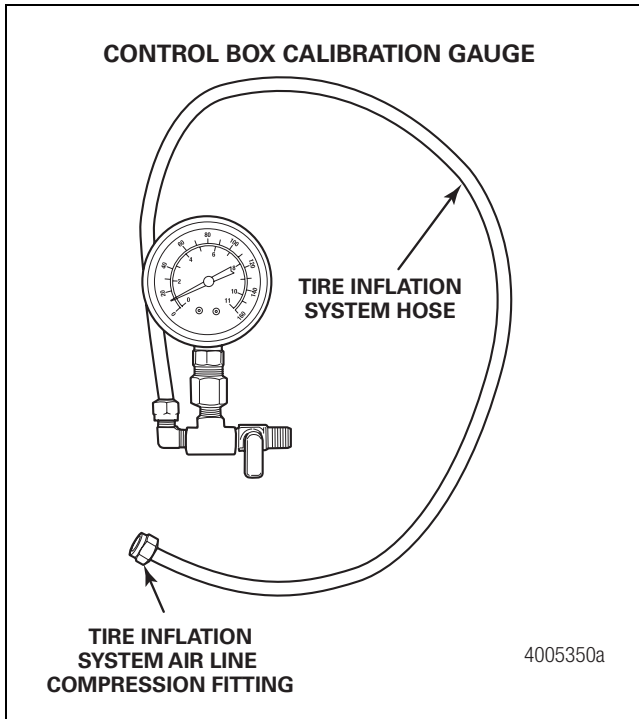

Figure 8.2

Meritor Heavy Vehicle Systems, LLC

2135 West Maple Road

Troy, MI 48084 USA

800-535-5560

arvinmeritor.com

Copyright 2006

ArvinMeritor, Inc.

Printed in USA

Revised 06-06

Installation and Maintenance Manual 14P (16579/22882)

ArvinMeritor™